

# NECO



CATALOGUE & TECHNICAL  
MANUAL 2025-2026

<https://www.necoparts.com>

CATALOGUE & TECHNICAL MANUAL 2025-2026



NECO

## NECO : NEVER COME OFF PROFESSIONAL BIKE PARTS MANUFACTURERS

Neco Technology Industry Co.Ltd., founded in 1986 in Taichung ,have been in the forefront of machinery tooling design and development. Having acquired more than 30 years of experience in the cycling field ,general manager Mr. Neco Wang has been extensively making contributions to not only the growth ,development and success of the company ,but to the global bicycle industry as well.

In order to offer high quality products and expand plant capacity, we specialize in manufacturing headsets and bottom bracket components. Not only can we cover a wide range of applications and finishes ,but we can also extend the capacities of alloy cold forging ,steel press ,hole tapping and CNC finishing ,etc.

Starting from 2010 ,Neco Ltd. has extended its product categories to include CNC pedals ,hubs and chainwheels, To offer the best service and shortest lead-time ,Neco Ltd. has established 4 factories in China ; one in Shunde City ,Guangdong(since 1997) ,one in Tianwang Town ,Jurong City (since 2001) and also the factory in Tianjin(since 2013).In 2016,Lingbei Motor Technology joined in Neco group, Lingbei Motor Technology(Shanghai)Co.,Ltd. is a company dedicated to the production of electric vehicle components and complete sets of systems, its products are exported to international, specializing in the motor system for electric bicycles pedal bicycles and, scooters its products are on sale in china, European and the American markets.

After constant improvement and efficient management ,every Neco factory is well established and play an important role in the Neco group.

Taiwan factory continuously focuses on high-end products and expanding design capabilities with our state-of-the-art research facility. However ,we believe the entire range of market demands from economic models to technologically cold forged CNC component.Meanwhile ,Neco Ltd. will always strive to meet the commitments to all of the customers and provide competitive and high-value products.



# 2025-2026 CATALOGUE & TECHNICAL MANUAL

## HEADSETS 車頭碗組

Cable Routing Headsets	內走線車頭碗組	P.02 - P.04
Integrated Threaded Headsets	全隱藏式無牙車頭碗	P.06 - P.11
Semi-Integrated Threadless Headsets	半隱藏式無牙車頭碗	P.11 - P.20
Semi-Integrated Threaded Headsets	半隱藏式有牙車頭碗	P.21 - P.24
External Cup Threadless Headsets	外露式無牙車頭碗	P.24 - P.30
130° Safety Headsets	安全車頭碗	P.31 - P.34
External Cup Threaded Headsets	外露式有牙車頭碗	P.34 - P.39
E-bike Head Parts	電動車車頭碗組	P.40

## ACCESSORIES 配件

Accessories	配件	P.42 - P.46
-------------	----	-------------

## BOTTOM BRACKETS B.B 五通碗組

Cartridge Cotterless B.B. Sets	P.48 - P.56
Cartridge ISIS B.B. Sets	P.57 - P.59
External Cup/ Press-Fit B.B. Sets/Bottom Brackets	P.60 - P.68

## PEDALS 腳踏

Clipless/CNC Pedals/BMX/City/Mountain/Road/Children 卡踏/鋁合金腳踏/表演車用/城市車用/登山車用/跑車用/童車用	P.70 - P.76
--	-------------

## HUBS 花鼓

Road/Mountain Bikes	跑車用/登山車用	P.78 - P.84
Quick Release	快拆	P.85

## PACKAGING 補修包裝

Packaging	補修包裝	P.86 - P.87
-----------	------	-------------

# CABLE ROUTING HEADSETS

內走線車頭碗組



**NECO**

# H322TP-1



**WEIGHT**

104.1g

**SIZE**

1.5" Head Tube  
Reduced To 1-1/8"  
Fork Tube Integrated  
Threadless Headset

**SHIS NORM**

IS52.2/28.6  
IS52.2/39.8(30)

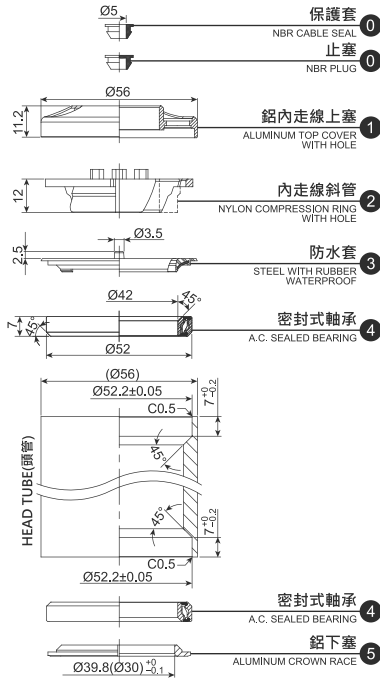

堆積高度 (STACK HEIGHT) = 10.1 ± 1mm

# H322MP-1WR



**WEIGHT**

91.7g

**SIZE**

1.5" Head Tube  
Reduced To 1-1/8"  
Fork Tube Integrated  
Threadless Headset

**SHIS NORM**

IS52.2/28.6  
IS52.2/39.8(30)

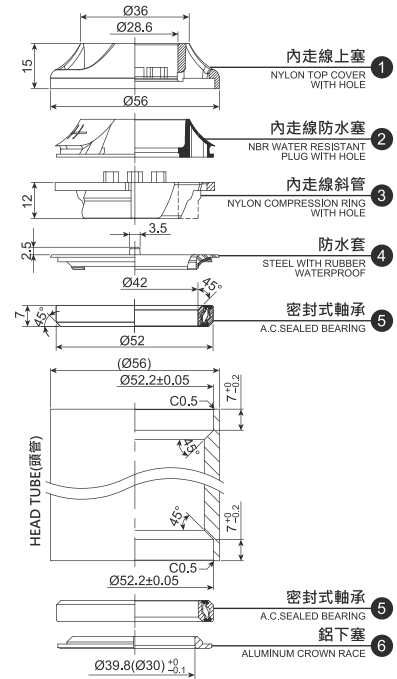

堆積高度 (STACK HEIGHT) = 16.8 ± 1 mm

# H324



**WEIGHT**

91.1g

**SIZE**

1.5" Head Tube  
Reduced To 1-1/8"  
Fork Tube Integrated  
Threadless Headset

**SHIS NORM**

IS52.2/28.6  
IS52.2/39.8(30)

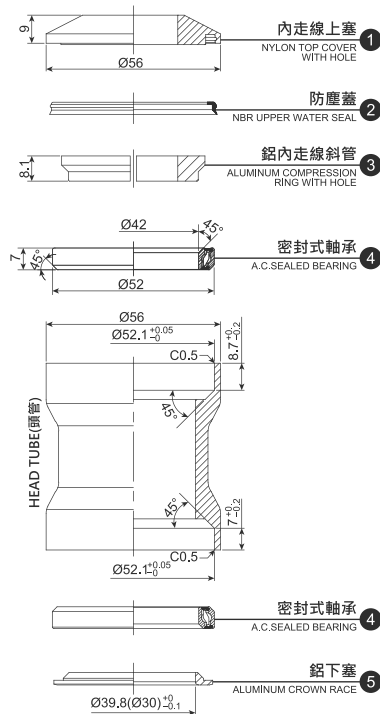

堆積高度 (STACK HEIGHT) = 10.6 ± 1 mm

# H326MP



**WEIGHT**

101.3g

**SIZE**

1.5" Head Tube  
Reduced To 1-1/8"  
Fork Tube Integrated  
Threadless Headset

**SHIS NORM**

IS52.2/28.6  
IS52.2/39.8(30)

Available For Zoom  
Stem Model

TW-AL-408

Available For UUR  
Stem Model

HB-400B

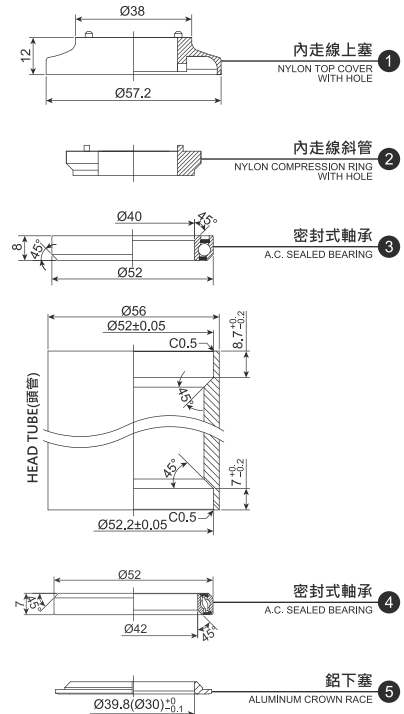

堆積高度 (STACK HEIGHT) = 13.4 ± 1 mm

## H329A

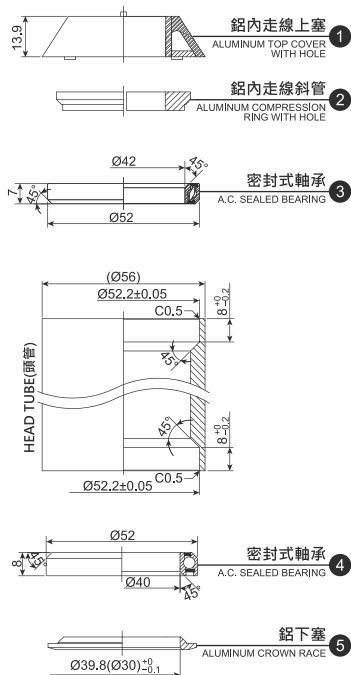

**WEIGHT**  
115.8g

**SIZE**  
1.5" Head Tube  
Reduced To 1-1/8" Fork  
Tube Integrated  
Threadless Headset

**SHIS NORM**  
IS52.2/28.6  
IS52.2/39.8(30)

Available For  
Zoom Stem Model

TDS-(R)D631-8FOV/  
TDS-D632-8FOV/  
TDS-D634-8FOV/  
TDS-636-8FOV  
TDS-645(SERIES)  
-8FOV/TDS-658-8FOV/  
TM-AL-20-8

**OPTIONAL**  
H329MP:  
NYLON TOP COVER

堆積高度 ( STACK HEIGHT ) = 15.5±1mm

## H331

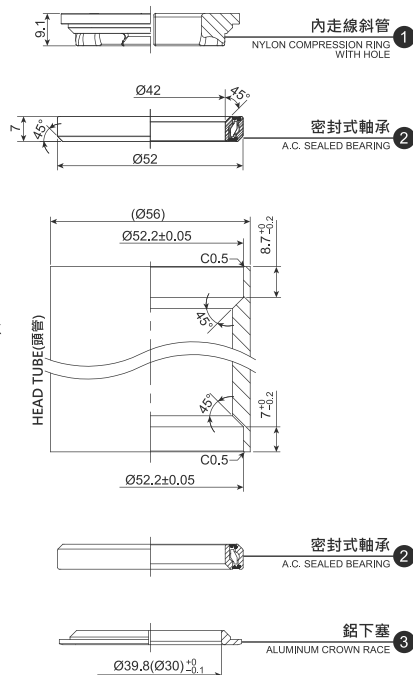

**WEIGHT**  
73.7g

**SIZE**  
1.5" Head Tube  
Reduced To 1-1/8" Fork  
Tube Integrated  
Threadless Headset

**SHIS NORM**  
IS52.2/28.6  
IS52.2/39.8(30)

Available For Zoom Model

TDS-(R)D631-8FOV/  
TDS-D632-8FOV/  
TDS-D634-8FOV/  
TDS-636-8FOV  
TDS-645(SERIES)  
-8FOV/TDS-658-8FOV/  
TM-AL-20-8

堆積高度 ( STACK HEIGHT ) = 1.8±0.5 mm

## H156ECR

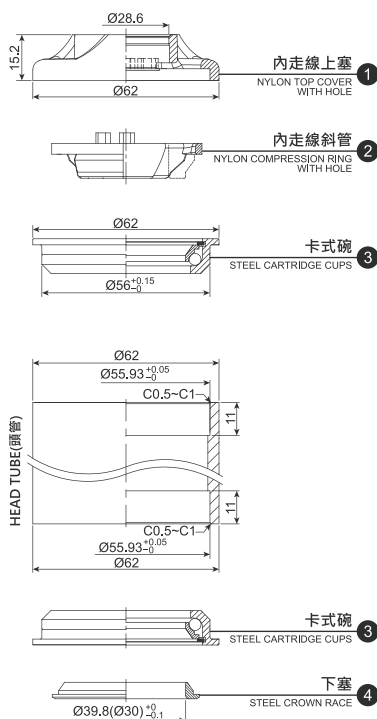

**WEIGHT**  
194.7g

**SIZE**  
1.5" Head Tube  
Reduced To 1-1/8" Fork  
Tube  
Semi-Integrated  
Threadless Headset

**SHIS NORM**  
ZS56/28.6  
ZS56/39.8(30)

堆積高度 ( STACK HEIGHT ) = 20.6 ± 1 mm

## H323MP-2WR

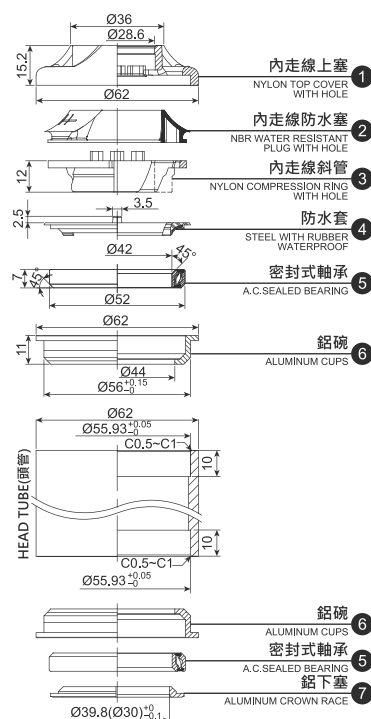

**WEIGHT**  
118g

**SIZE**  
1.5" Head Tube  
Reduced To 1-1/8" Fork  
Tube Semi-Integrated  
Threadless Headset

**SHIS NORM**  
ZS56/28.6  
ZS56/39.8(30)

堆積高度 ( STACK HEIGHT ) = 21.1 ± 1 mm

# H325MP



**WEIGHT**

119.5g

**SIZE**

1.5" Head Tube  
Reduced To 1-1/8" Fork  
Tube Semi-Integrated  
Threadless Headset

**SHIS NORM**

ZS56/28.6  
ZS56/39.8(30)

Available For  
Bigstone Model  
M300C

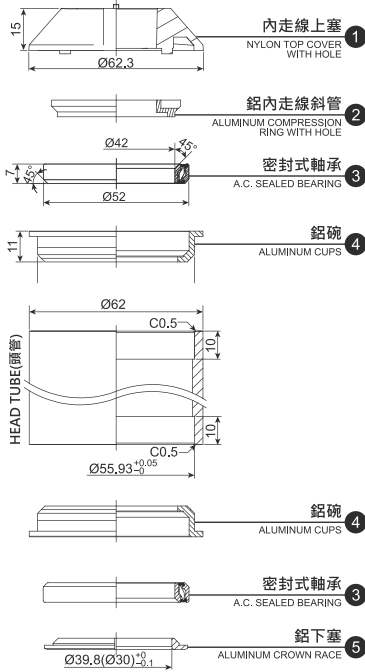

堆積高度 ( STACK HEIGHT ) = 20.3±1mm

# H330A



**WEIGHT**

176.9g

**SIZE**

1.5" Head Tube  
Reduced To 1-1/8" Fork  
Tube Semi-Integrated  
Threadless Headset

**SHIS NORM**

ZS56/28.6  
ZS56/39.8(30)

Available For Zoom Model

TDS-(R)D631-8FOV/  
TDS-D632-8FOV/  
TDS-D634-8FOV/  
TDS-636-8FOV  
TDS-645(SERIES)-  
8FOV/TDS-658-8FOV/  
TM-AL-20-8

**OPTIONAL**

H330MP:  
NYLON TOP COVER

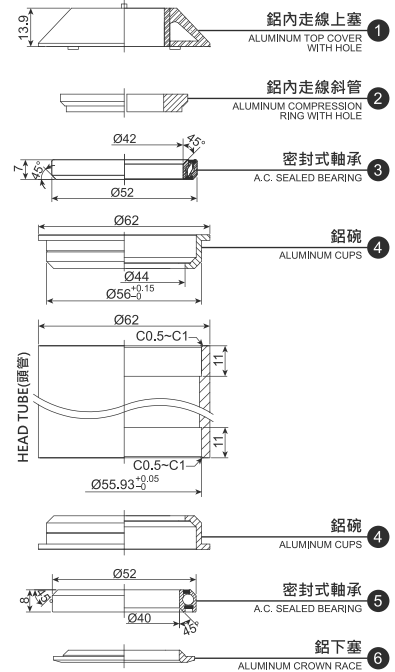

堆積高度 ( STACK HEIGHT ) = 19.5±1 mm

# H334

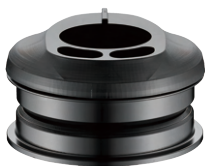

**WEIGHT**

117.4g

**SIZE**

1.5" Head Tube  
Reduced To 1-1/8" Fork  
Tube Semi-Integrated  
Threadless Headset

**SHIS NORM**

ZS56/28.6  
ZS56/39.8(30)

Available For Zoom Model

TDS-(R)D631-8FOV/  
TDS-D632-8FOV/  
TDS-D634-8FOV/  
TDS-636-8FOV  
TDS-645(SERIES)-  
8FOV/TDS-658-8FOV/  
TM-AL-20-8

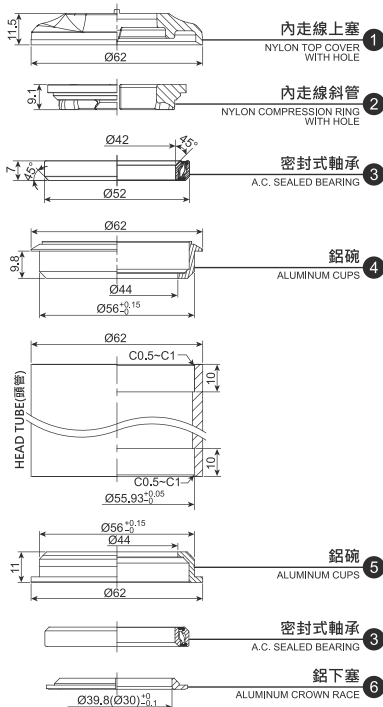

堆積高度 ( STACK HEIGHT ) = 15.4 ± 1 mm

# H335



**WEIGHT**

133g

**SIZE**

1.5" Head Tube  
Reduced To 1-1/8" Fork  
Tube Semi-Integrated  
Threadless Headset

**SHIS NORM**

ZS56/28.6  
ZS56/39.8(30)

Available For  
OrbitN-E Model

AS-E08

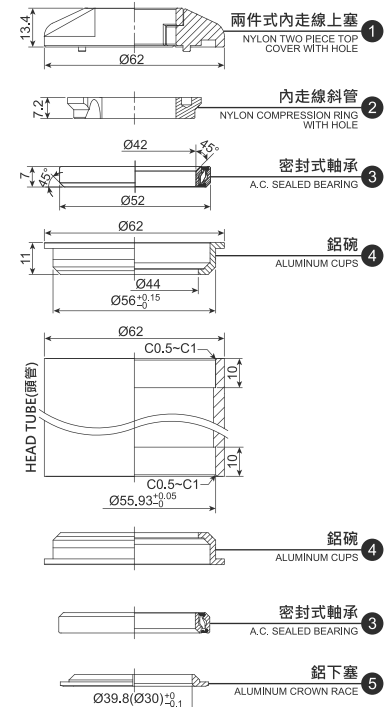

堆積高度 ( STACK HEIGHT ) = 18.9 ± 1 mm

# HEADSETS

## 車頭碗組



**NECO**

# H02



**WEIGHT**

50g

**SIZE**

1" Integrated Threadless Headset

**SHIS NORM**

IS38.2/25.4  
IS38.2/27(26.4)

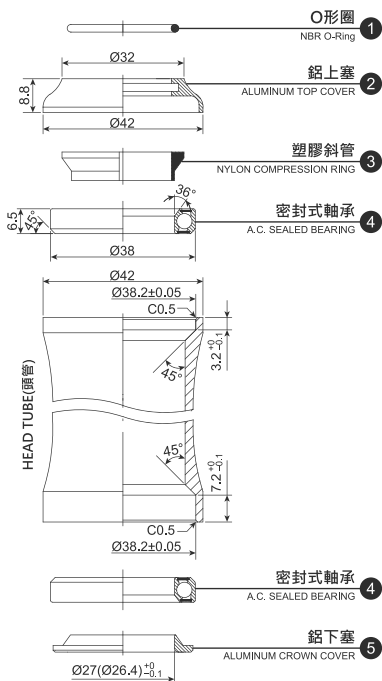

堆積高度 (STACK HEIGHT) =  $10.5 \pm 1\text{mm}$

# H22



**WEIGHT**

55g

**SIZE**

1-1/8" Integrated Threadless Headset

**SHIS NORM**

IS41.2/28.6  
IS41.2/30

可選配之上塞高度 (TOP COVER IS OPTIONAL)

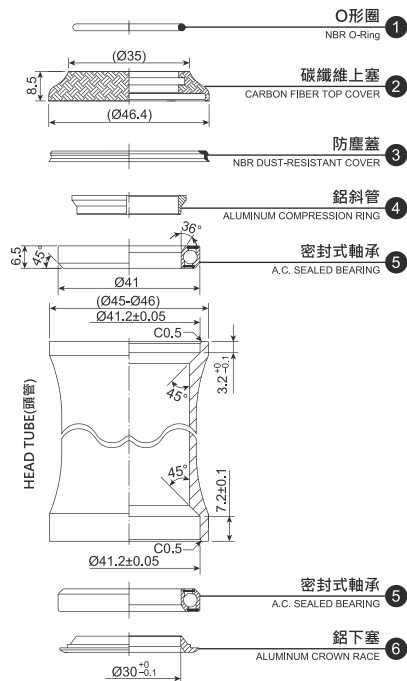
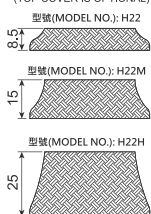

堆積高度 (STACK HEIGHT) =  $10.2 \pm 1\text{mm}$

# H23



**WEIGHT**

60.3g

**SIZE**

1-1/8" Integrated Threadless Headset

**SHIS NORM**

IS41.2/28.6  
IS41.2/30

可選配之上塞高度 (TOP COVER IS OPTIONAL)

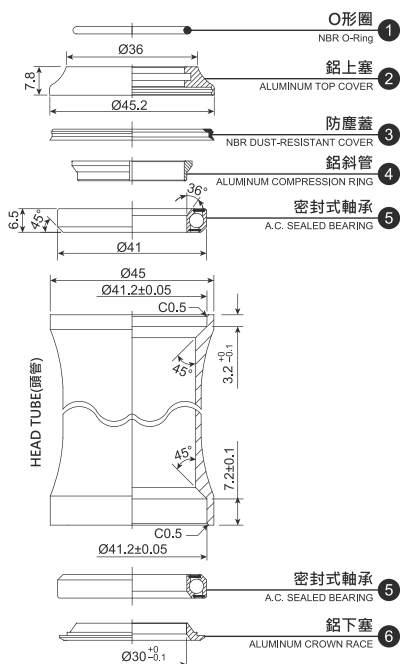
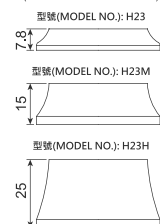

堆積高度 (STACK HEIGHT) =  $9.5 \pm 1\text{mm}$

# H27



**WEIGHT**

61g

**SIZE**

1-1/8" Integrated Threadless Headset  
Campy Compatible

**SHIS NORM**

IS42/28.6  
IS42/30

可選配之上塞高度 (TOP COVER IS OPTIONAL)

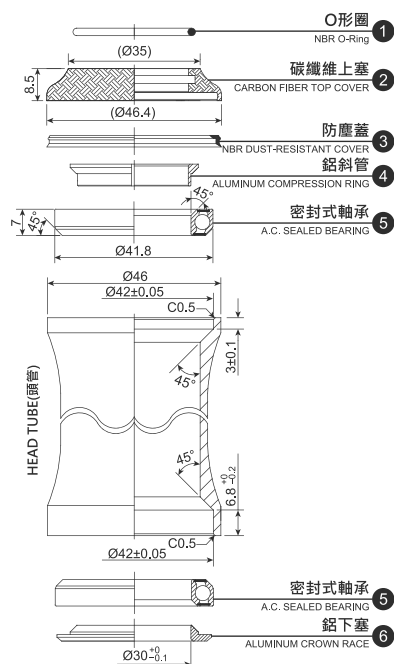
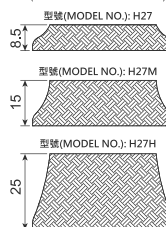

堆積高度 (STACK HEIGHT) =  $10.1 \pm 1\text{mm}$

# NECO INTEGRATED THREADLESS HEADSETS

全隱藏式無牙車頭碗 INTEGRATED THREADLESS HEADSETS

## H50



### WEIGHT

64g

### SIZE

1-1/8" Integrated Threadless Headset

### SHIS NORM

IS41.2/28.6  
IS41.2/30

可選配之上塞高度  
(TOP COVER IS OPTIONAL)

型號(MODEL NO.): H50

型號(MODEL NO.): H50M

型號(MODEL NO.): H50H

型號(MODEL NO.): H50H

型號(MODEL NO.): H50H

型號(MODEL NO.): H50H

型號(MODEL NO.): H50H

型號(MODEL NO.): H50H

型號(MODEL NO.): H50H

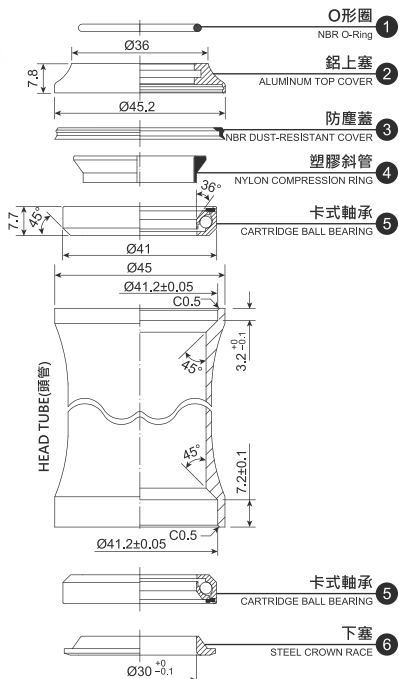

堆積高度 ( STACK HEIGHT ) = 9.8 ± 1 mm

## H51



### WEIGHT

65g

### SIZE

1-1/8" Integrated Threadless Headset  
Campy Compatible

### SHIS NORM

IS42/28.6  
IS42/30

可選配之上塞高度  
(TOP COVER IS OPTIONAL)

型號(MODEL NO.): H51

型號(MODEL NO.): H51M

型號(MODEL NO.): H51H

型號(MODEL NO.): H51H

型號(MODEL NO.): H51H

型號(MODEL NO.): H51H

型號(MODEL NO.): H51H

型號(MODEL NO.): H51H

型號(MODEL NO.): H51H

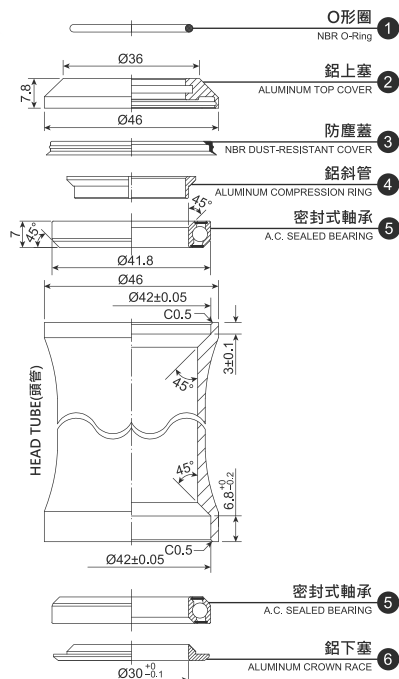

堆積高度 ( STACK HEIGHT ) = 9.4 ± 1 mm

## H51S



### WEIGHT

70g

### SIZE

1-1/8" Head Tube  
Reduced to 1" Fork  
Stem Integrated  
Threadless Headset

### SHIS NORM

IS42/25.4  
IS42/27(26.4)

可選配之上塞高度  
(TOP COVER IS OPTIONAL)

型號(MODEL NO.): H51S

型號(MODEL NO.): H51SM

型號(MODEL NO.): H51SH

型號(MODEL NO.): H51SH

型號(MODEL NO.): H51SH

型號(MODEL NO.): H51SH

型號(MODEL NO.): H51SH

型號(MODEL NO.): H51SH

型號(MODEL NO.): H51SH

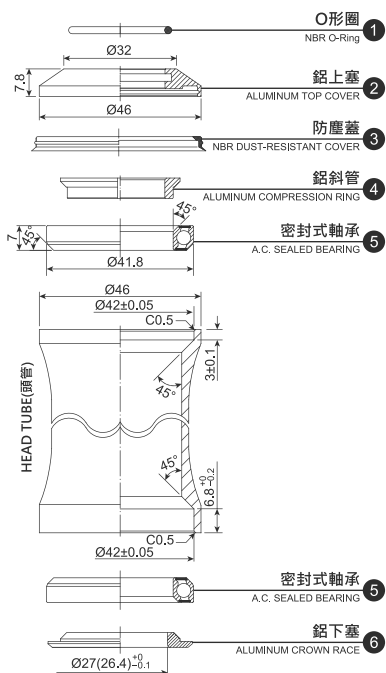

堆積高度 ( STACK HEIGHT ) = 9.4 ± 1 mm

## H52



### WEIGHT

74g

### SIZE

1-1/8" Integrated Threadless Headset  
Campy Compatible

### SHIS NORM

IS42/28.6  
IS42/30

可選配之上塞高度  
(TOP COVER IS OPTIONAL)

型號(MODEL NO.): H52

型號(MODEL NO.): H52M

型號(MODEL NO.): H52H

型號(MODEL NO.): H52H

型號(MODEL NO.): H52H

型號(MODEL NO.): H52H

型號(MODEL NO.): H52H

型號(MODEL NO.): H52H

型號(MODEL NO.): H52H

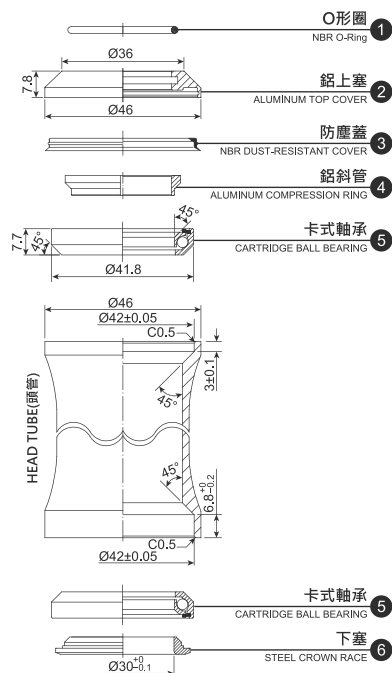

堆積高度 ( STACK HEIGHT ) = 9.4 ± 1 mm

# H52MP



**WEIGHT**

70g

**SIZE**

1-1/8" Integrated Threadless Headset Campy Compatible

**SHIS NORM**

IS42/28.6  
IS42/30

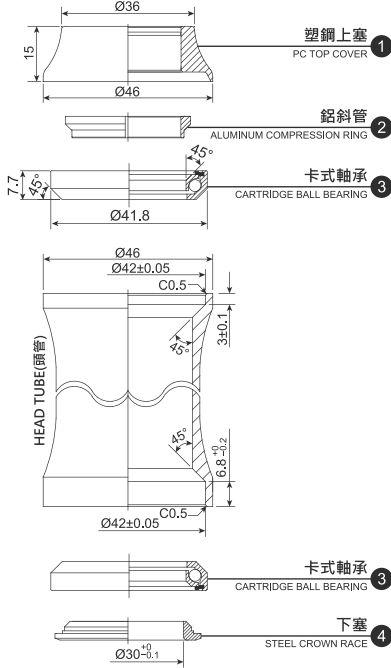

# H160



**WEIGHT**

85g

**SIZE**

1.5" Head Tube Reduced to 1-1/4" Fork Tube Integrated Threadless Headset

**SHIS NORM**

IS47/31.8  
IS52.2/39.8(33)

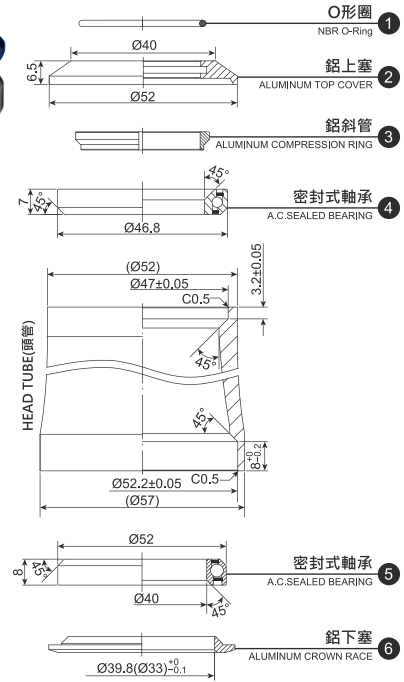

# H373 [H373C]



**WEIGHT**

80g

**SIZE**

1.5" Head Tube Reduced to 1-1/8" Fork Tube Integrated Threadless Headset

**SHIS NORM**

IS42/28.6  
IS52.2/39.8(30)

**OPTIONAL**

H373C-Carbon Top Cover Stack Height 10.4 ± 1mm

可選配之上塞高度 (TOP COVER IS OPTIONAL)

型號(MODEL NO.): H373

型號(MODEL NO.): H373M

型號(MODEL NO.): H373H

型號(MODEL NO.): H373SH

型號(MODEL NO.): H373SH

型號(MODEL NO.): H373SH

型號(MODEL NO.): H373SH

型號(MODEL NO.): H373SH

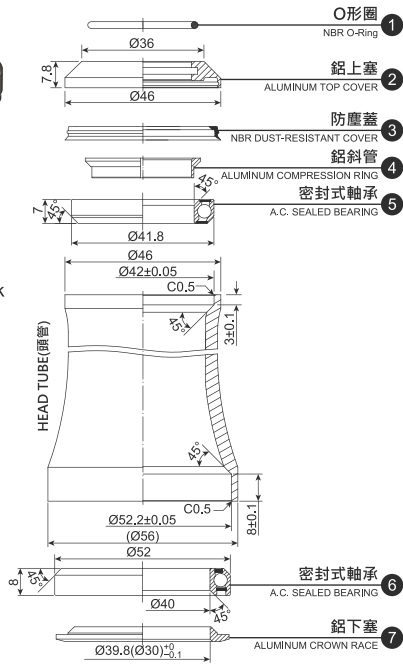

# H373S



**WEIGHT**

83.6g

**SIZE**

1.5" Head Tube Reduced to 1-1/8" Fork Tube Integrated Threadless Headset

**SHIS NORM**

IS42/28.6  
IS52.2/39.8(30)

可選配之上塞高度 (TOP COVER IS OPTIONAL)

型號(MODEL NO.): H373S

型號(MODEL NO.): H373SM

型號(MODEL NO.): H373SH

型號(MODEL NO.): H373SH

型號(MODEL NO.): H373SH

型號(MODEL NO.): H373SH

型號(MODEL NO.): H373SH

型號(MODEL NO.): H373SH

型號(MODEL NO.): H373SH

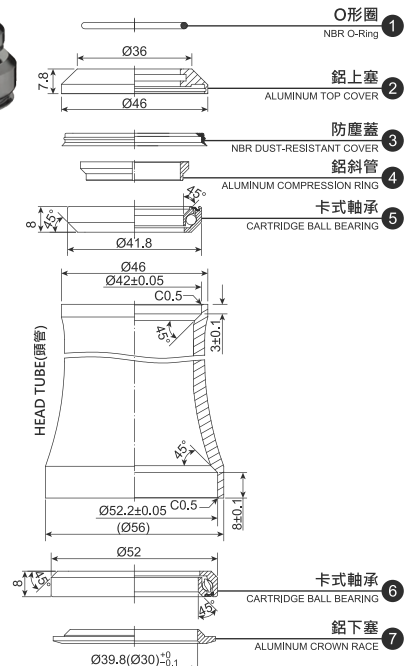

# NECO INTEGRATED THREADLESS HEADSETS

全隱藏式無牙車頭碗 INTEGRATED THREADLESS HEADSETS

## H373MPS



**WEIGHT**

88g

**SIZE**

1.5" Head Tube  
Reduced to 1-1/8"  
Fork Tube Integrated  
Threadless Headset

**SHIS NORM**

IS42/28.6  
IS52.2/39.8 (30)

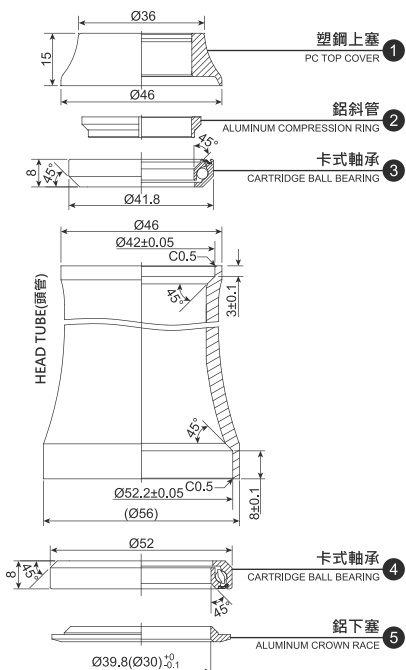

堆積高度 (STACK HEIGHT) = 16.3 ± 1 mm

## H373-B52



**WEIGHT**

80g

**SIZE**

1.5" Head Tube  
Reduced to 1-1/8"  
Fork Tube Integrated  
Threadless Headset

**SHIS NORM**

IS42/28.6  
IS52/39.8(30)

可選配之上塞高度  
(TOP COVER IS OPTIONAL)  
型號(MODEL NO.): H373M-B52

型號(MODEL NO.): H373M-B52

型號(MODEL NO.): H373H-B52

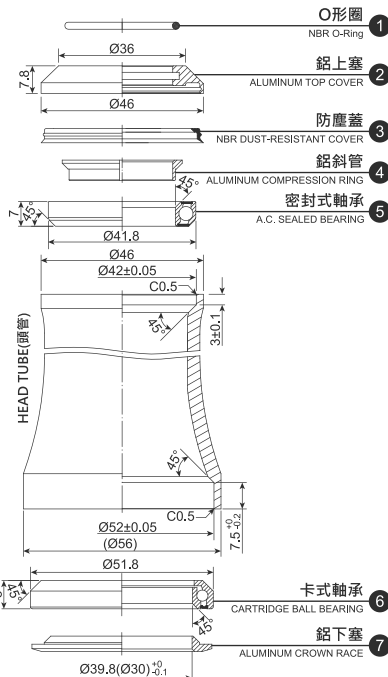

堆積高度 (STACK HEIGHT) = 9.5 ± 1 mm

## H373FT-B52



**WEIGHT**

75g

**SIZE**

1.5" Head Tube  
Reduced to 1-1/8"  
Fork Tube Integrated  
Threadless Headset

**SHIS NORM**

IS42/28.6  
IS52/39.8(30)

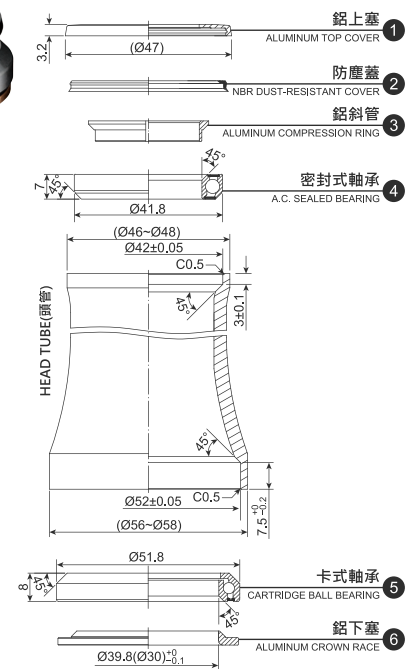

堆積高度 (STACK HEIGHT) = 4.5 ± 1 mm

## H373G



**WEIGHT**

87g

**SIZE**

1.5" Head Tube  
Reduced to 1-1/8"  
Fork Tube Integrated  
Threadless Headset

**SHIS NORM**

IS42/28.6  
IS52.2/39.8(30)

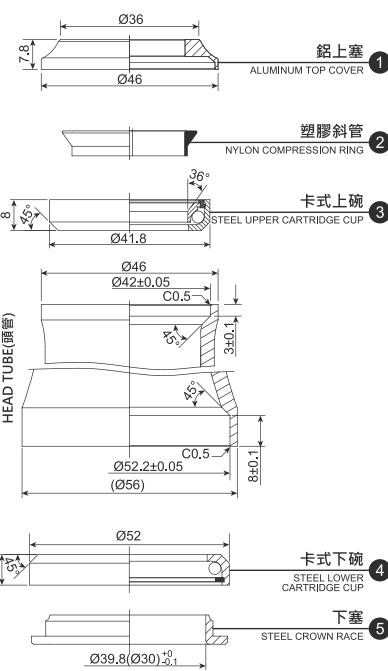

堆積高度 (STACK HEIGHT) = 9.1 ± 1 mm

# H373GMP



1 塑膠上塞  
PC TOP COVER



2 鋁斜管  
ALUMINUM COMPRESSION RING

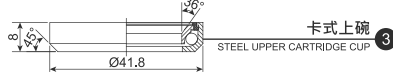

3 卡式上碗  
STEEL UPPER CARTRIDGE CUP

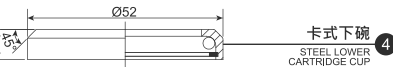
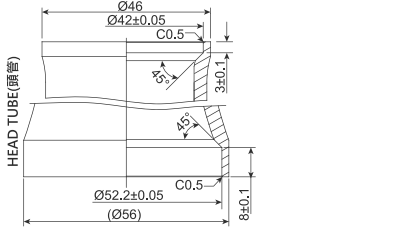

4 卡式下碗  
STEEL LOWER CARTRIDGE CUP

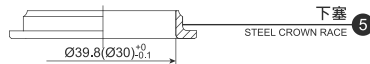

5 下塞  
STEEL CROWN RACE

**WEIGHT**

88g

**SIZE**

1.5" Head Tube  
Reduced to 1-1/8"  
Fork Tube Integrated  
Threadless Headset

**SHIS NORM**

IS42/28.6  
IS52.2/39.8(30)

堆積高度 (STACK HEIGHT) = 16.6 ± 1 mm

# H382 [1.5"]



1 O形圈  
NBR O-Ring

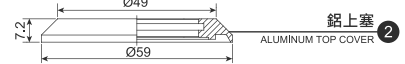

2 鋁上塞  
ALUMINUM TOP COVER



3 鋁斜管  
ALUMINUM COMPRESSION RING

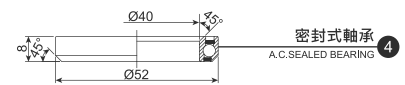

4 密封式軸承  
A.C. SEALED BEARING

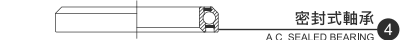
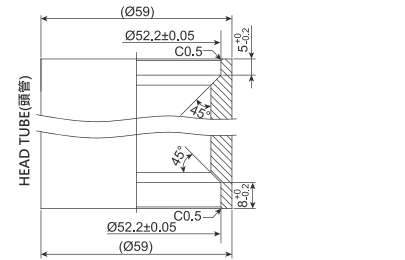

4 密封式軸承  
A.C. SEALED BEARING

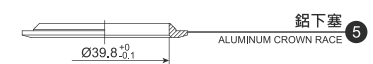

5 鋁下塞  
ALUMINUM CROWN RACE

**WEIGHT**

99g

**SIZE**

1.5" Integrated  
Threadless Headset

**SHIS NORM**

IS52.2/38.1  
IS52.2/39.8

堆積高度 (STACK HEIGHT) = 9.1 ± 1 mm

# H382S



1 O形圈  
NBR O-RING

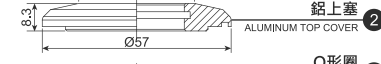

2 鋁上塞  
ALUMINUM TOP COVER

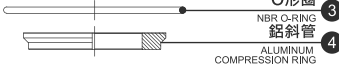

3 O形圈  
NBR O-RING  
4 鋁斜管  
ALUMINUM COMPRESSION RING

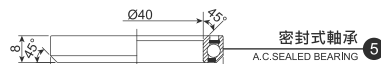

5 密封式軸承  
A.C. SEALED BEARING

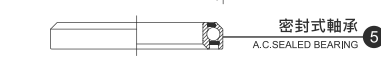
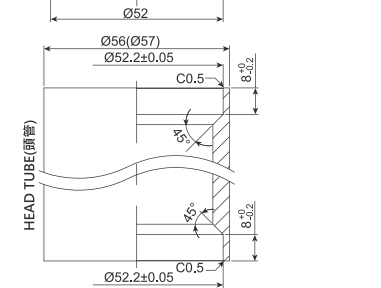

5 密封式軸承  
A.C. SEALED BEARING

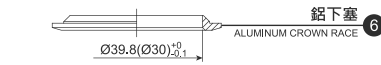

6 鋁下塞  
ALUMINUM CROWN RACE

**WEIGHT**

113.3g

**SIZE**

1.5" Head Tube  
Reduced to 1-1/8"  
Fork Tube Integrated  
Threadless Headset

**SHIS NORM**

IS52.2/28.6  
IS52.2/39.8(30)

可選配之上塞高度  
(TOP COVER IS OPTIONAL)  
型號(MODEL NO.): H382SM

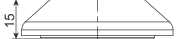

堆積高度 (STACK HEIGHT) = 8.7 ± 1 mm

# H397

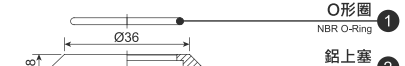

1 O形圈  
NBR O-Ring

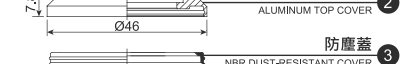

2 鋁上塞  
ALUMINUM TOP COVER

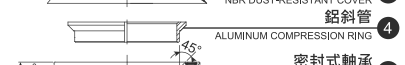

3 防塵蓋  
NBR DUST-RESISTANT COVER  
4 鋁斜管  
ALUMINUM COMPRESSION RING

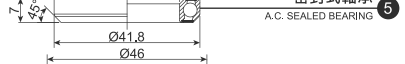

5 密封式軸承  
A.C. SEALED BEARING

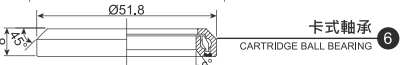
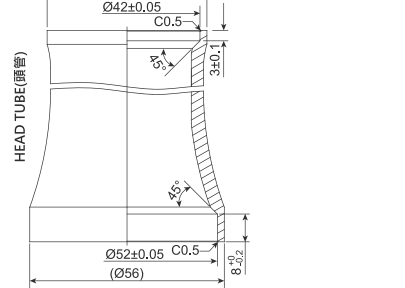

6 卡式軸承  
CARTRIDGE BALL BEARING

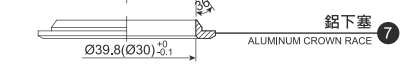

7 鋁下塞  
ALUMINUM CROWN RACE

**WEIGHT**

76g

**SIZE**

1.5" Head Tube  
Reduced to 1-1/8"  
Fork Tube Integrated  
Threadless Headset

**SHIS NORM**

IS42/28.6  
IS52/39.8(30)

可選配之上塞高度  
(TOP COVER IS OPTIONAL)  
型號(MODEL NO.): H397

型號(MODEL NO.): H397M

型號(MODEL NO.): H397H



堆積高度 (STACK HEIGHT) = 9.5 ± 1 mm

全隱藏式無牙車頭碗 INTEGRATED THREADLESS HEADSETS  
半隱藏式無牙車頭碗 SEMI-INTEGRATED THREADLESS HEADSETS

### H398



**WEIGHT**

76g

**SIZE**

1-1/4" Head Tube  
Reduced to 1-1/8"  
Fork Tube Integrated  
Threadless Headset

**SHIS NORM**

IS42/28.6  
IS47.2/33(30)

可選配之上塞高度  
(TOP COVER IS OPTIONAL)

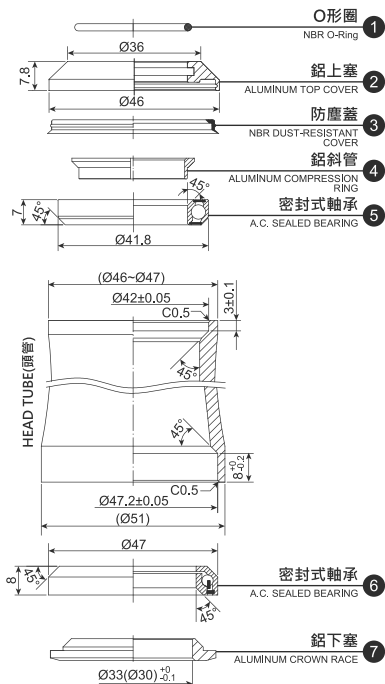
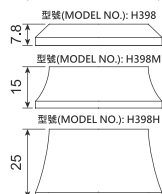

堆積高度 (STACK HEIGHT) = 9.7 ± 1 mm



### H100



**WEIGHT**

123g

**SIZE**

1-1/4" Head Tube  
Reduced to 1-1/8"  
Fork Tube  
Semi-Integrated  
Threadless Headset

**SHIS NORM**

ZS44/28.6  
ZS50.6/33(30)

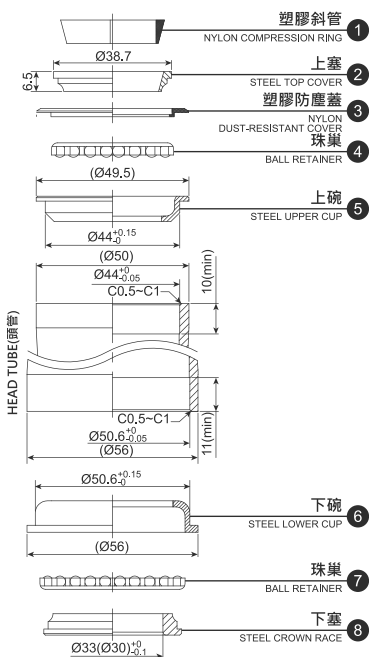

堆積高度 (STACK HEIGHT) = 8.7 ± 1 mm

### H100M-1 [H100H-1]



**WEIGHT**

149g

**SIZE**

1-1/4" Head Tube  
Reduced to 1-1/8"  
Fork Tube  
Semi-Integrated  
Threadless Headset

**SHIS NORM**

ZS44/28.6  
ZS50.6/33(30)

可選配之上塞高度  
(TOP COVER IS OPTIONAL)

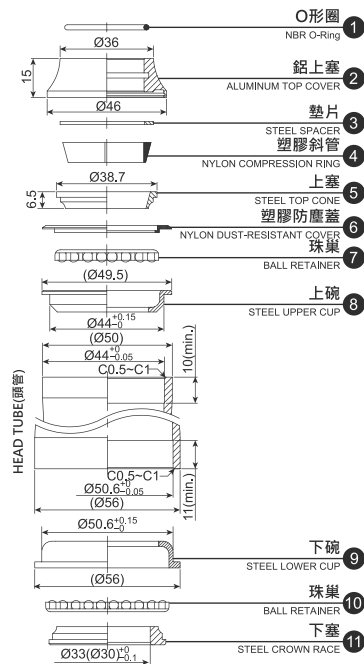
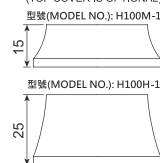

堆積高度 (STACK HEIGHT) = 22.5 ± 1 mm

# H114



**WEIGHT**

105g

**SIZE**

1-1/8"  
Semi-Integrated  
Threadless Headset

**SHIS NORM**

ZS44/28.6  
ZS44/30

可選配之上塞高度  
(TOP COVER IS OPTIONAL)

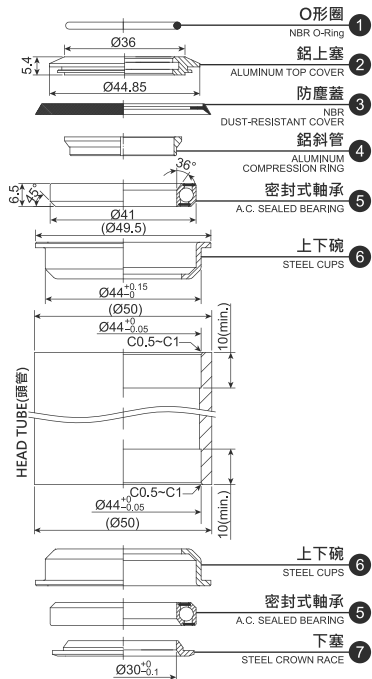
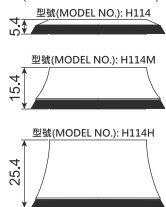

堆積高度 ( STACK HEIGHT ) = 9.9 ± 1 mm

# H115



**WEIGHT**

97g

**SIZE**

1-1/8"  
Semi-Integrated  
Threadless Headset

**SHIS NORM**

ZS44/28.6  
ZS44/30

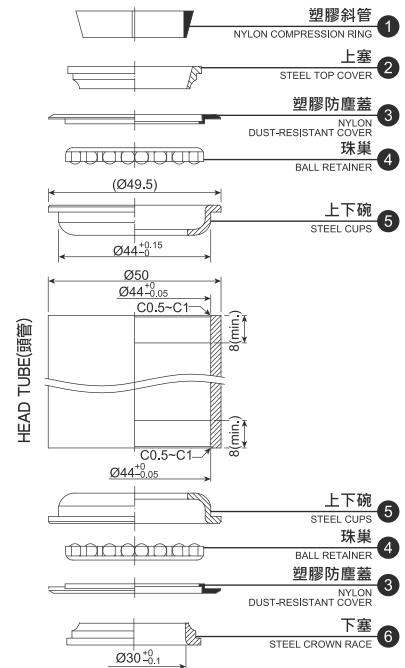

堆積高度 ( STACK HEIGHT ) = 9.8 ± 1 mm

# H115MP



**WEIGHT**

113g

**SIZE**

1-1/8"  
Semi-Integrated  
Threadless Headset

**SHIS NORM**

ZS44/28.6  
ZS44/30

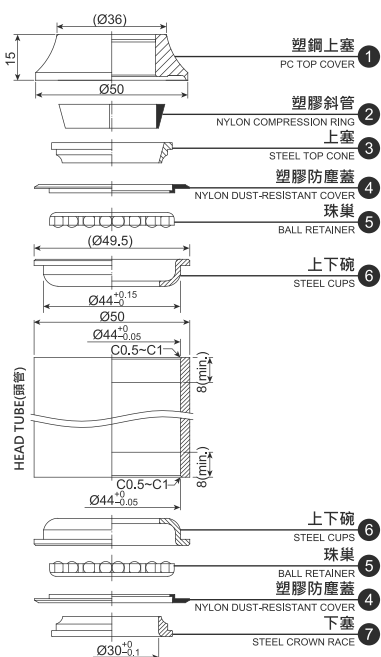

堆積高度 ( STACK HEIGHT ) = 23.6 ± 1 mm

# H115M-1 [H115H-1]



**WEIGHT**

H115M-1:121g  
H115H-1:138g

**SIZE**

1-1/8"  
Semi-Integrated  
Threadless Headset

**SHIS NORM**

ZS44/28.6  
ZS44/30

可選配之上塞高度  
(TOP COVER IS OPTIONAL)

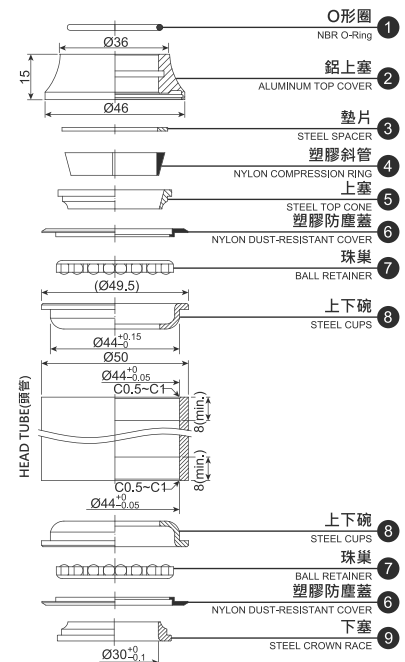
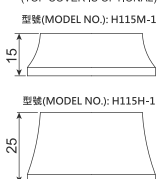

堆積高度 ( STACK HEIGHT ) = 23.2 ± 1 mm

# NECO SEMI-INTEGRATED THREADLESS HEADSETS

半隱藏式無牙車頭碗 SEMI-INTEGRATED THREADLESS HEADSETS

## H117DM



**WEIGHT**

106g

**SIZE**

1-1/8"  
Semi-integrated  
Threadless Headset

**SHIS NORM**

ZS44/28.6  
ZS44/30

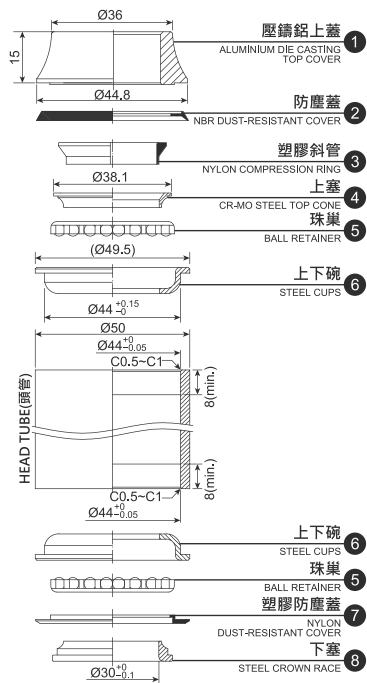

堆積高度 ( STACK HEIGHT ) = 23 ± 1 mm

## H117SM



**WEIGHT**

99g

**SIZE**

1-1/8"  
Semi-Integrated  
Threadless Headset

**SHIS NORM**

ZS44/28.6  
ZS44/30

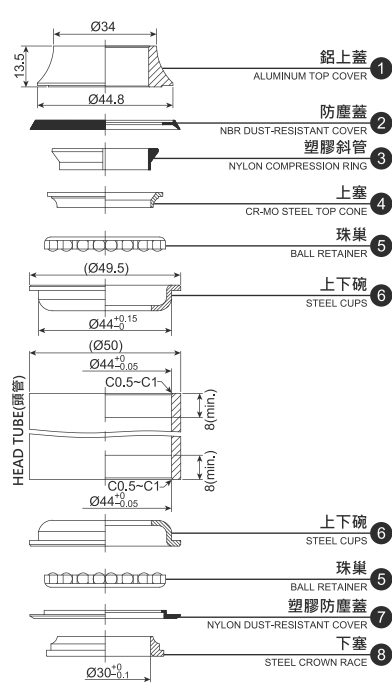

堆積高度 ( STACK HEIGHT ) = 21.2 ± 1 mm

## H119CDM



**WEIGHT**

141.3g

**SIZE**

1-1/8"  
Semi-Integrated  
Threadless Headset

**SHIS NORM**

ZS44/28.6  
ZS44/30

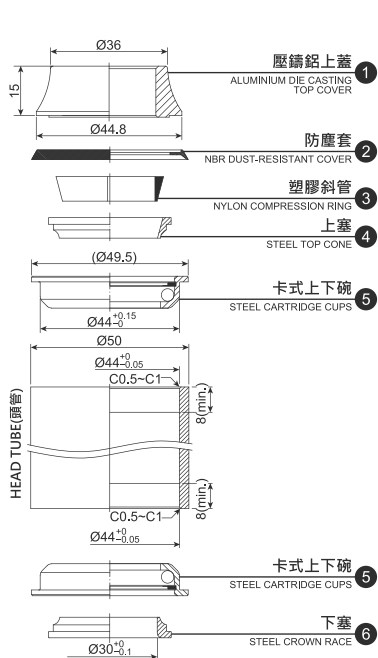

堆積高度 ( STACK HEIGHT ) = 21.2 ± 1 mm

## H119MP-1



**WEIGHT**

96g

**SIZE**

1-1/8"  
Semi-integrated  
Threadless Headset

**SHIS NORM**

ZS44/28.6  
ZS44/30

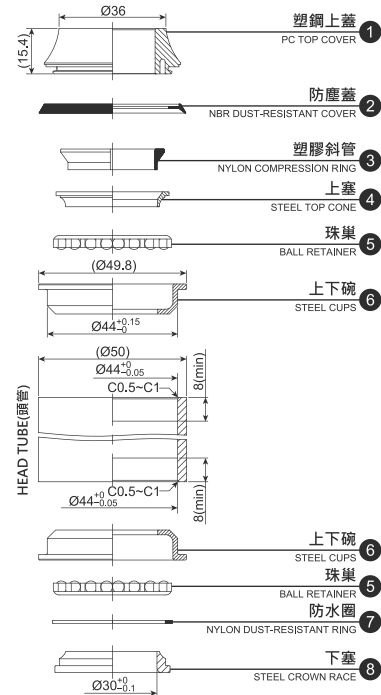

堆積高度 ( STACK HEIGHT ) = 19.2 ± 1 mm

# H124



**WEIGHT**

91g

**SIZE**

1" Semi-Integrated  
Threadless Headset

**SHIS NORM**

ZS44/25.4  
ZS44/27(26.4)

可選配之上塞高度  
(TOP COVER IS OPTIONAL)

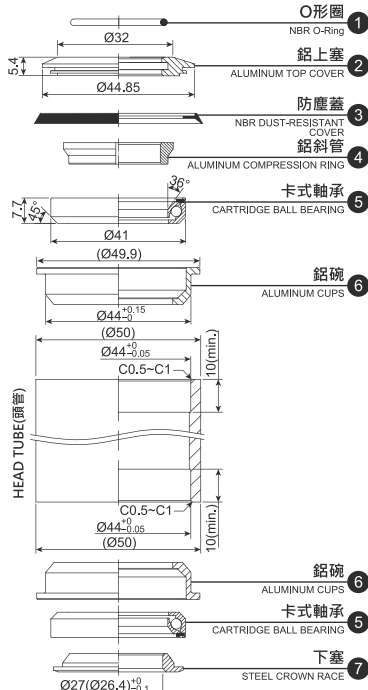
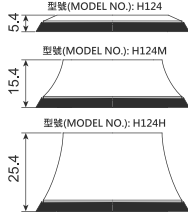

堆積高度 (STACK HEIGHT) = 10 ± 1 mm

# H125



**WEIGHT**

60.8g

**SIZE**

1-1/8"  
Semi-Integrated  
Threadless Headset

**SHIS NORM**

ZS44/28.6  
ZS44/30

可選配之上塞高度  
(TOP COVER IS OPTIONAL)

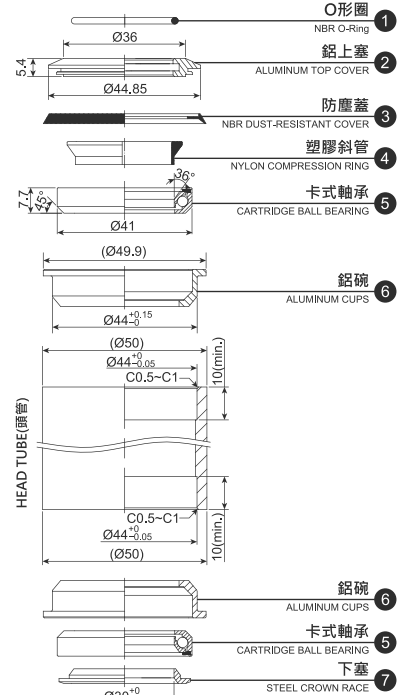
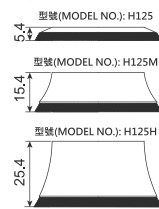

堆積高度 (STACK HEIGHT) = 10 ± 1 mm

# H145



**WEIGHT**

77g

**SIZE**

1-1/8"  
Semi-Integrated  
Threadless Headset

**SHIS NORM**

ZS44/28.6  
ZS44/30

可選配之上塞高度  
(TOP COVER IS OPTIONAL)

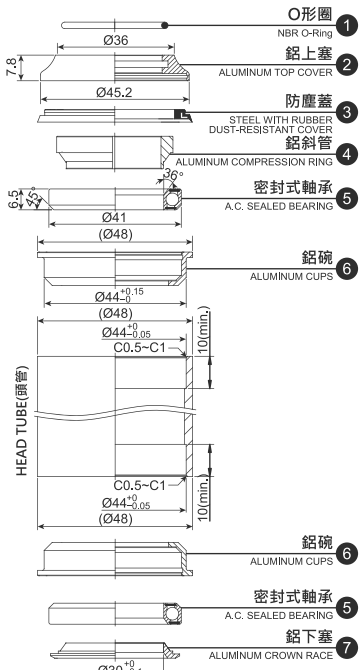
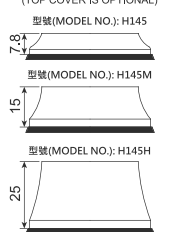

堆積高度 (STACK HEIGHT) = 14.1 ± 1 mm

# H146



**WEIGHT**

77.8g

**SIZE**

1-1/8"  
Semi-Integrated  
Threadless Headset

**SHIS NORM**

ZS44/28.6  
ZS44/30

可選配之上塞高度  
(TOP COVER IS OPTIONAL)

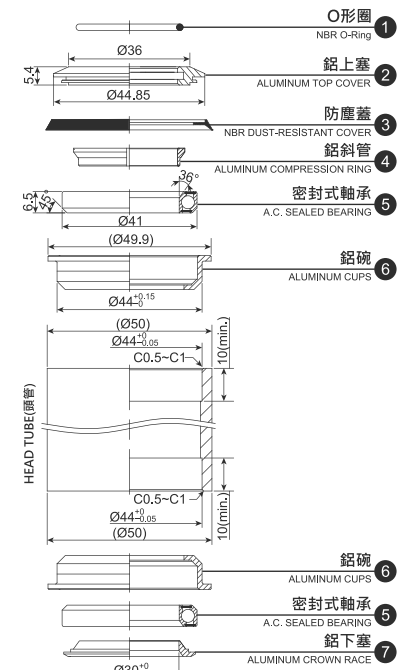
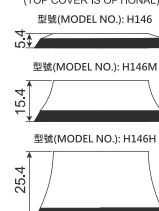

堆積高度 (STACK HEIGHT) = 9.1 ± 1 mm

# NECO SEMI-INTEGRATED THREADLESS HEADSETS

半隱藏式無牙車頭碗 SEMI-INTEGRATED THREADLESS HEADSETS

## H148



**WEIGHT**

106g

**SIZE**

1-1/8"  
Semi-Integrated  
Threadless Headset

**SHIS NORM**

ZS44/28.6  
ZS44/30

可選配之上塞高度  
(TOP COVER IS OPTIONAL)

型號(MODEL NO.): H148



型號(MODEL NO.): H148M



型號(MODEL NO.): H148H

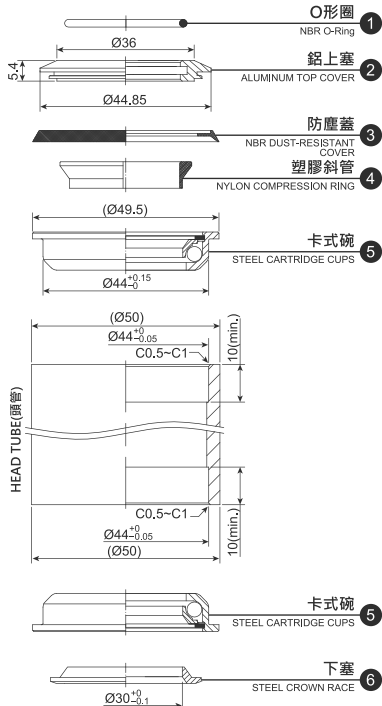
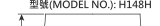

堆積高度 (STACK HEIGHT) = 9.9 ± 1 mm

## H148MP



**WEIGHT**

103.3g

**SIZE**

1-1/8"  
Semi-Integrated  
Threadless Headset

**SHIS NORM**

ZS44/28.6  
ZS44/30

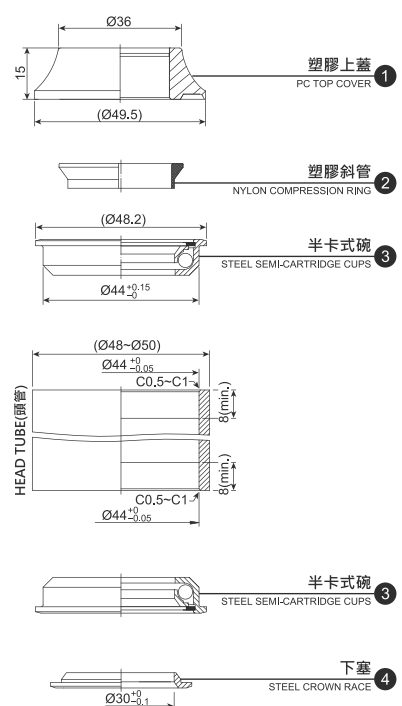

堆積高度 (STACK HEIGHT) = 19.5 ± 1 mm

## H148MP-1



**WEIGHT**

107.7g

**SIZE**

1-1/8"  
Semi-Integrated  
Threadless Headset

**SHIS NORM**

ZS44/28.6  
ZS44/30

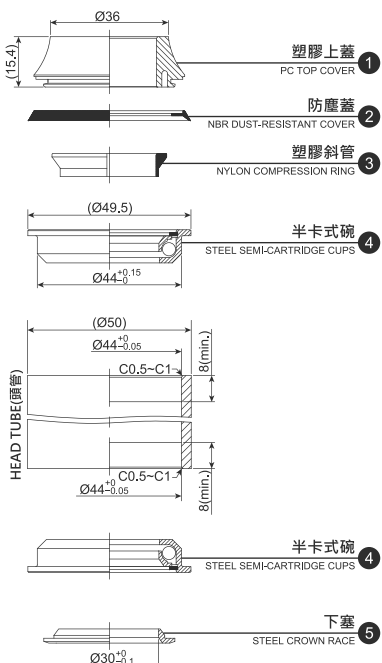

堆積高度 (STACK HEIGHT) = 19.5 ± 1 mm

## H148DM



**WEIGHT**

122.8g

**SIZE**

1-1/8"  
Semi-Integrated  
Threadless Headset

**SHIS NORM**

ZS44/28.6  
ZS44/30

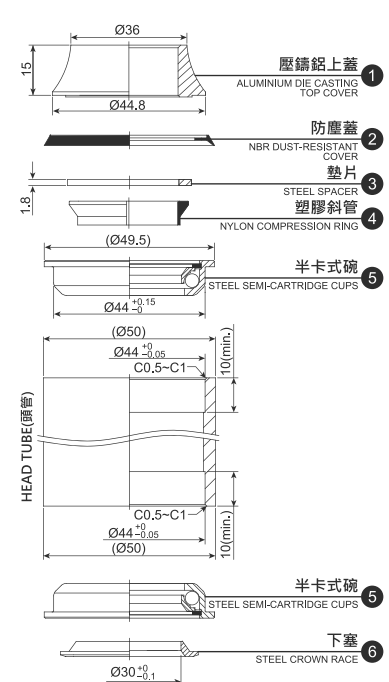

堆積高度 (STACK HEIGHT) = 21.6 ± 1 mm

# H151S



**WEIGHT**

119g

**SIZE**

Fits 1-1/8" to 1.5"  
Tapered Fork  
Threadless Headset

**SHIS NORM**

ZS44/28.6  
EC44/39.8(30)

可選配之上塞高度  
(TOP COVER IS OPTIONAL)

型號(MODEL NO.): H151S

型號(MODEL NO.): H151SM

型號(MODEL NO.): H151SH

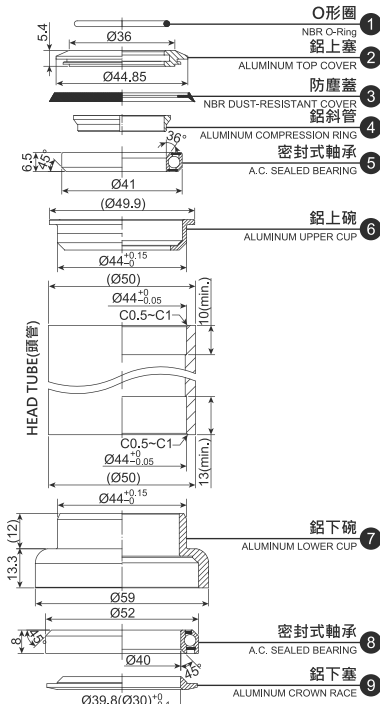

堆積高度 (STACK HEIGHT) = 20.2 ± 1 mm

# H153-1 [H153E-1]



**WEIGHT**

135g

**SIZE**

1.5" Head Tube  
Reduced to 1-1/8"  
Fork Tube  
Semi-Integrated  
Threadless headset

**SHIS NORM**

ZS55(56)/28.6  
ZS55(56)/39.8(30)

可選配之上塞高度  
(TOP COVER IS OPTIONAL)

型號(MODEL NO.): H153M-1(H153ME-1)

型號(MODEL NO.): H153H-1(H153HE-1)

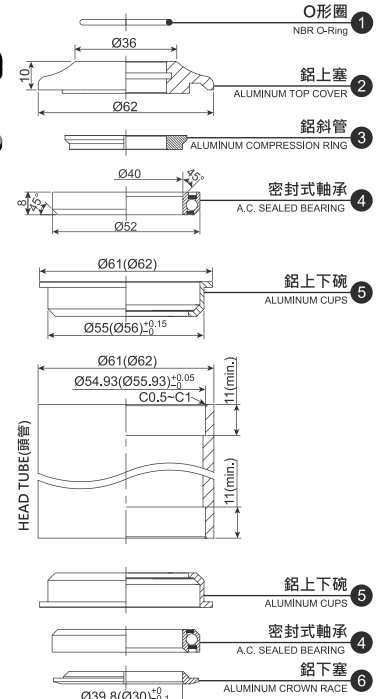

堆積高度 (STACK HEIGHT) = 15.6 ± 1 mm

# H153E-1-001



**WEIGHT**

197.3g

**SIZE**

1.5" Head Tube  
Reduced to 1-1/8"  
Fork Tube Integrated  
Threadless Headset

**SHIS NORM**

ZS56/28.6  
ZS66/45.8(39.8)

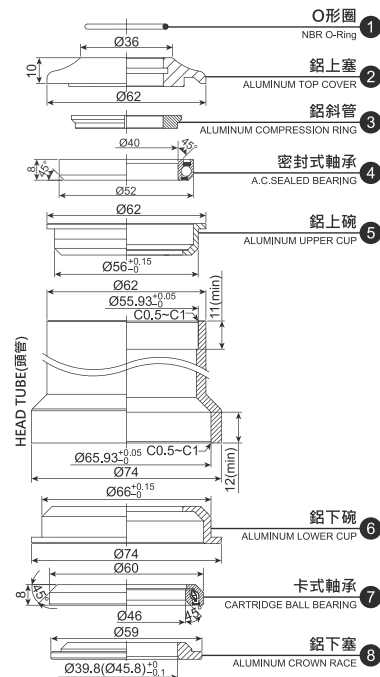

堆積高度 (STACK HEIGHT) = 15.7 ± 1 mm

# H153-1C [H153E-1C]



**WEIGHT**

145g

**SIZE**

1.5" Head Tube  
Reduced to 1-1/8"  
Fork Tube  
Semi-Integrated  
Threadless headset

**SHIS NORM**

ZS55(56)/28.6  
ZS55(56)/39.8(30)

可選配之上塞高度  
(TOP COVER IS OPTIONAL)

型號(MODEL NO.): H153M-1C(H153ME-1C)

型號(MODEL NO.): H153H-1C(H153HE-1C)

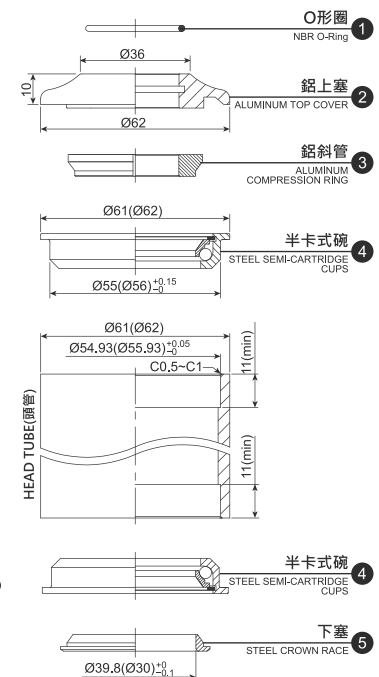

堆積高度 (STACK HEIGHT) = 15.8 ± 1 mm

# NECO SEMI-INTEGRATED THREADLESS HEADSETS

半隱藏式無牙車頭碗 SEMI-INTEGRATED THREADLESS HEADSETS

## H156 [H156E]



**WEIGHT**

134g

**SIZE**

1.5" Head Tube Reduced to 1-1/8" Fork Tube Semi-Integrated Threadless headset

**SHIS NORM**

ZS44/28.6  
ZS55/39.8(30)

**OPTIONAL**

H156E:ZS44/28.6  
ZS56/39.8(30)

可選配之上塞高度  
(TOP COVER IS OPTIONAL)

型號(MODEL NO.): H156

型號(MODEL NO.): H156M

型號(MODEL NO.): H156H

25.4

15.4

5.4

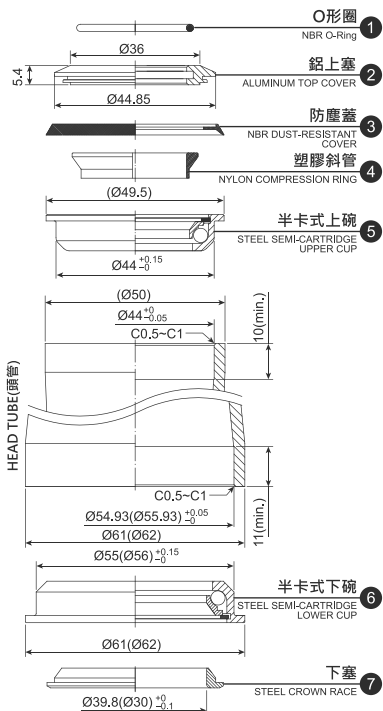

堆積高度 (STACK HEIGHT) = 9.9 ± 1 mm

## H156MP [H156EMP]



**WEIGHT**

133g

**SIZE**

1.5" Head Tube Reduced to 1-1/8" Fork Tube Semi-Integrated Threadless headset

**SHIS NORM**

ZS44/28.6  
ZS55/39.8(30)

**OPTIONAL**

H156EMP:ZS44/28.6  
ZS56/39.8(30)

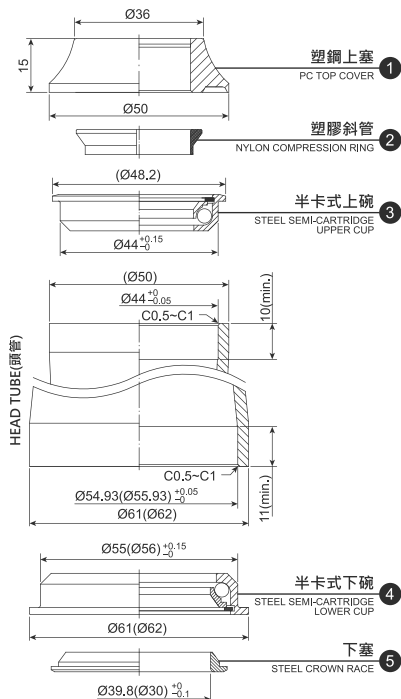

堆積高度 (STACK HEIGHT) = 19.5 ± 1 mm

## H159 [H159E]



**WEIGHT**

127g

**SIZE**

1.5" Head Tube Reduced to 1-1/8" Fork Tube Semi-Integrated Threadless headset

**SHIS NORM**

ZS44/28.6  
ZS55/39.8(30)

**OPTIONAL**

H159E:ZS44/28.6  
ZS56/39.8(30)

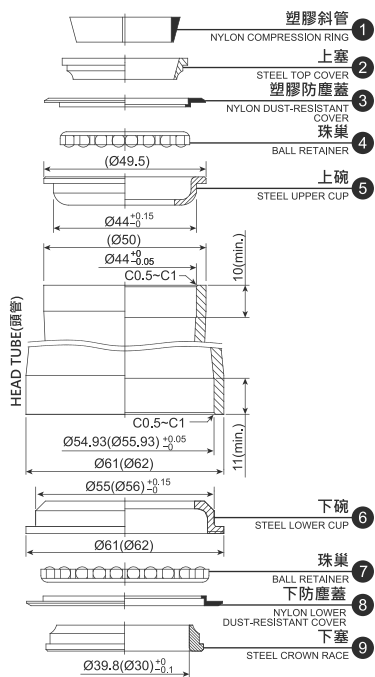

堆積高度 (STACK HEIGHT) = 9.7 ± 1 mm

## H162



**WEIGHT**

82g

**SIZE**

1" Semi-Integrated Threadless Headset

**SHIS NORM**

ZS44/25.4  
ZS44/27(26.4)

可選配之上塞高度  
(TOP COVER IS OPTIONAL)

型號(MODEL NO.): H162M

型號(MODEL NO.): H162H

15.4

25.4

5.4

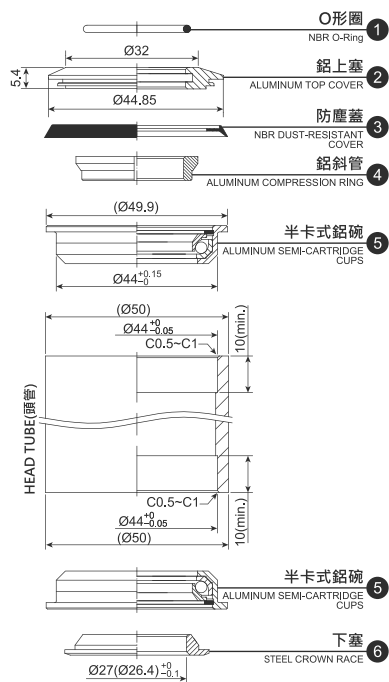

堆積高度 (STACK HEIGHT) = 9.1 ± 1 mm

# H172

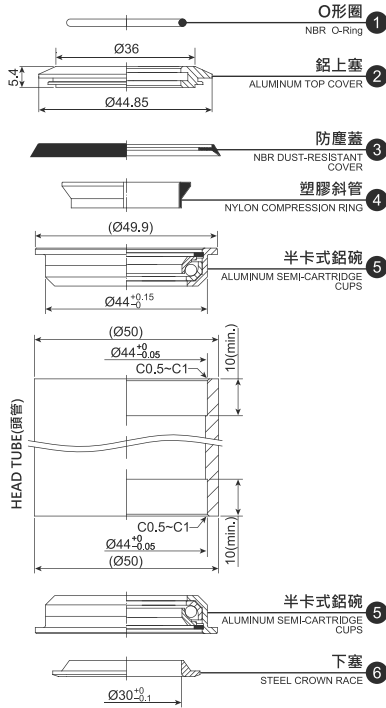

堆積高度 (STACK HEIGHT) = 9.1 ± 1 mm

**WEIGHT**

75g

**SIZE**

1-1/8" Semi-Integrated Threadless Headset

**SHIS NORM**

ZS44/28.6  
ZS44/30

可選配之上塞高度  
(TOP COVER IS OPTIONAL)

型號(MODEL NO.): H172

型號(MODEL NO.): H172M

型號(MODEL NO.): H172H

# H176

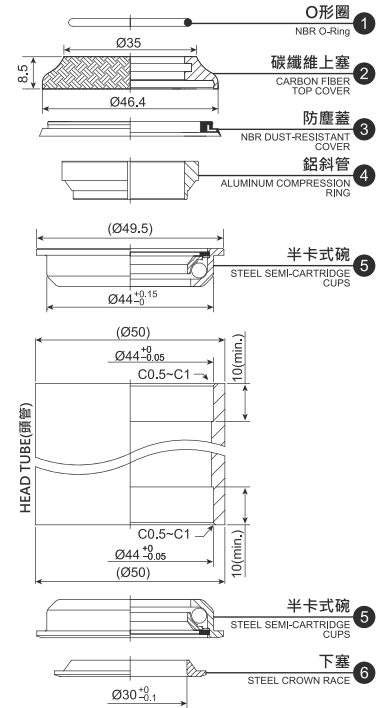

堆積高度 (STACK HEIGHT) = 14.6 ± 1 mm

**WEIGHT**

112g

**SIZE**

1-1/8" Semi-Integrated Threadless Headset

**SHIS NORM**

ZS44/28.6  
ZS44/30

可選配之上塞高度  
(TOP COVER IS OPTIONAL)

型號(MODEL NO.): H176

型號(MODEL NO.): H176M

型號(MODEL NO.): H176H

# H180

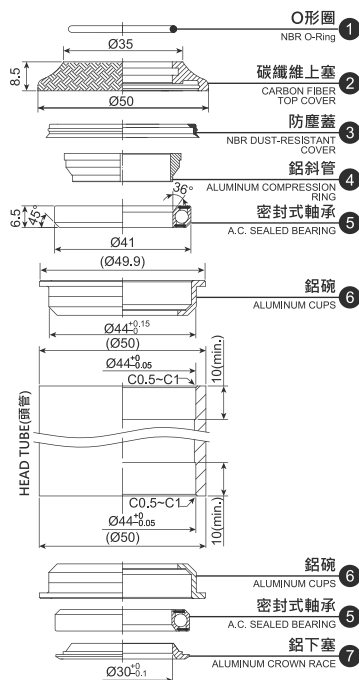

堆積高度 (STACK HEIGHT) = 13.7 ± 1 mm

**WEIGHT**

75g

**SIZE**

1-1/8" Semi-Integrated Threadless Headset

**SHIS NORM**

ZS44/28.6  
ZS44/30

可選配之上塞高度  
(TOP COVER IS OPTIONAL)

型號(MODEL NO.): H180

型號(MODEL NO.): H180M

型號(MODEL NO.): H180H

# H185

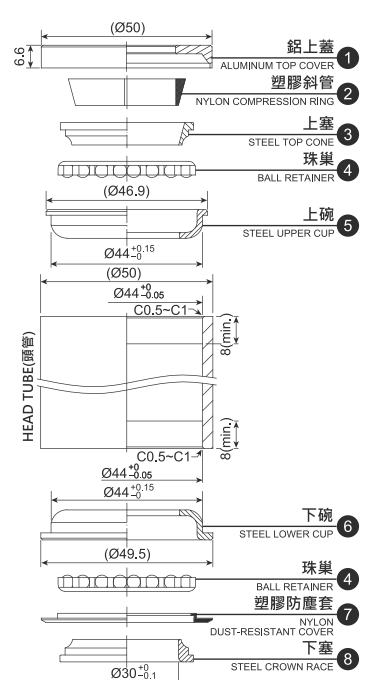

堆積高度 (STACK HEIGHT) = 11.7 ± 1 mm

**WEIGHT**

98g

**SIZE**

1-1/8" Semi-Integrated Threadless Headset

**SHIS NORM**

ZS44/28.6  
ZS44/30

# NECO SEMI-INTEGRATED THREADLESS HEADSETS

半隱藏式無牙車頭碗 SEMI-INTEGRATED THREADLESS HEADSETS

## H187



**WEIGHT**

130g

**SIZE**

1-1/4" Head Tube  
Reduced to 1-1/8"  
Fork Tube  
Semi-Integrated  
Threadless Headset

**SHIS NORM**

ZS44/28.6  
ZS50.6/33(30)

可選配之上塞高度  
(TOP COVER IS OPTIONAL)  
型號(MODEL NO.): H187

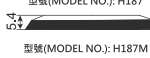

型號(MODEL NO.): H187M



型號(MODEL NO.): H187H

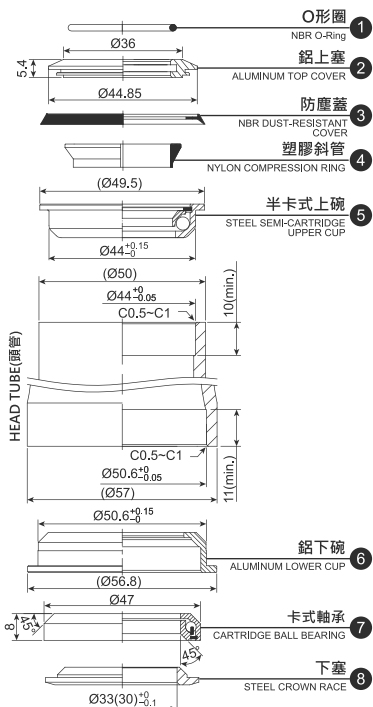

堆積高度 (STACK HEIGHT) = 9.9 ± 1 mm

## H188



**WEIGHT**

106g

**SIZE**

1-1/4" Head Tube  
Reduced to 1-1/8"  
Fork Tube  
Semi-Integrated  
Threadless Headset

**SHIS NORM**

ZS44/28.6  
ZS50.6/33(30)

可選配之上塞高度  
(TOP COVER IS OPTIONAL)  
型號(MODEL NO.): H188

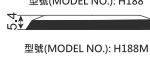

型號(MODEL NO.): H188M



型號(MODEL NO.): H188H

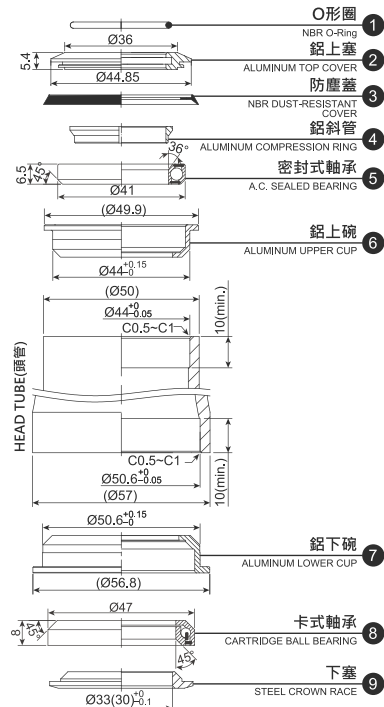

堆積高度 (STACK HEIGHT) = 9.2 ± 1 mm

## H189



**WEIGHT**

102g

**SIZE**

1-1/4" Reduced to  
1-1/8" Fork Tube  
Semi-Integrated  
Threadless Headset

**SHIS NORM**

ZS41.4/28.6  
ZS50.6/33(30)

可選配之上塞高度  
(TOP COVER IS OPTIONAL)  
型號(MODEL NO.): H189

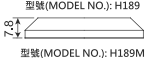

型號(MODEL NO.): H189M

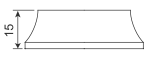

型號(MODEL NO.): H189H

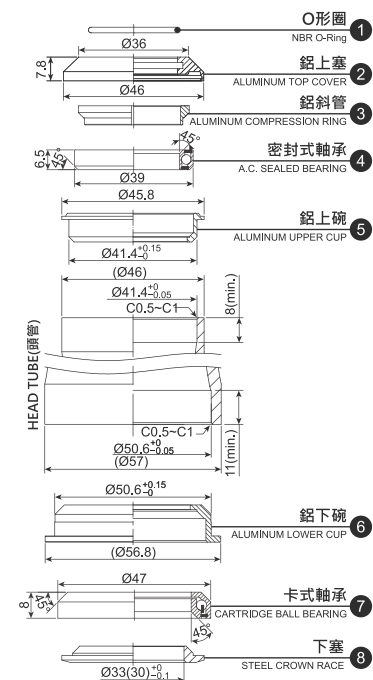

堆積高度 (STACK HEIGHT) = 12.2 ± 1 mm

## H332L

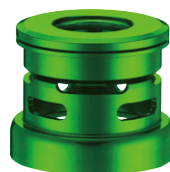

**WEIGHT**

82g

**SIZE**

1.5" Head Tube  
Reduced to 1-1/8"  
Fork Tube  
Semi-Integrated  
+ External Cup  
Threadless Headset

**SHIS NORM**

ZS49.7/28.6  
EC49.7/39.8(30)

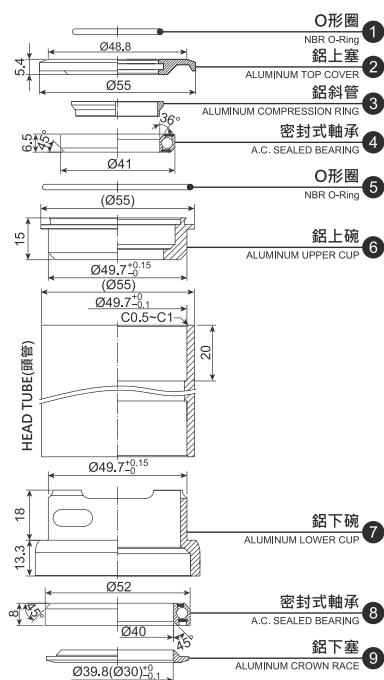

堆積高度 (STACK HEIGHT) = 20.3 ± 1 mm

# H369-3

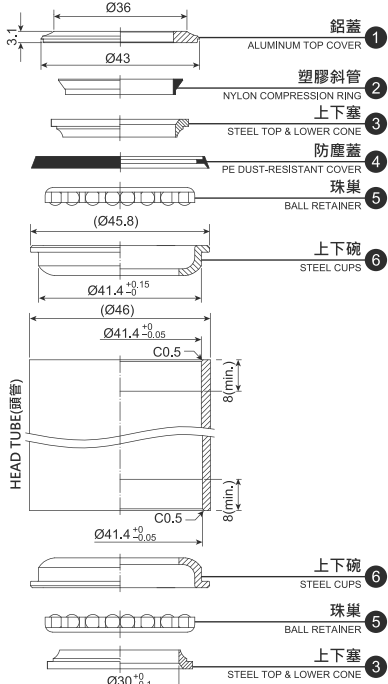

**WEIGHT**

70g

**SIZE**

1-1/8"  
Semi-Integrated  
Threadless Headset

**SHIS NORM**

ZS41.4/28.6  
ZS41.4 /30

可選配之上塞高度  
(TOP COVER IS OPTIONAL)

型號(MODEL NO.): H369-3

3.1

型號(MODEL NO.): H369M-3

15.1

型號(MODEL NO.): H369H-3

25.1

堆積高度 ( STACK HEIGHT ) = 10.2 ± 1 mm

# H383 [H383A]



**H384 [H384A]**

**WEIGHT**

106g

**SIZE**

1.5" Head Tube Reduced  
to 1-1/8" Fork Tube  
Semi-Integrated  
Threadless Headset

**SHIS NORM**

ZS44/28.6  
ZS55/39.8 (H383)

**OPTIONAL**

H384 #6 Crown Race  
ID:30.0mm

**SHIS NORM**

ZS44/28.6  
ZS55/30(H384)

**OPTIONAL MATERIAL**

H383A/H384A :  
Aluminum lower cup  
and Crown Race

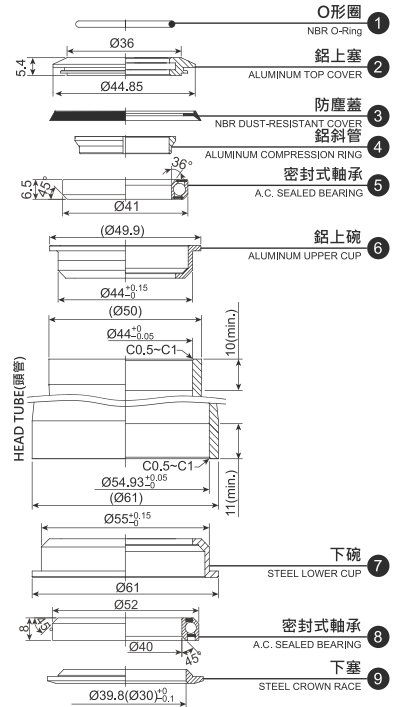

堆積高度 ( STACK HEIGHT ) = 9.5 ± 1 mm

# H383AE [H384AE]



**WEIGHT**

105g

**SIZE**

1.5" Head Tube Reduced  
to 1-1/8" Fork Tube Semi-  
Integrated Threadless Headset

**SHIS NORM**

ZS44/28.6  
ZS56/39.8(H383AE)

**OPTIONAL**

H384AE #6 Crown  
Race ID:30.0mm

**SHIS NORM**

ZS44/28.6  
ZS56/30(H384AE)

可選配之上塞高度  
(TOP COVER IS OPTIONAL)

型號(MODEL NO.):H383AE(H384AE)

5.4

型號(MODEL NO.):H383AEM(H384AEM)

15.4

型號(MODEL NO.):H383AEH(H384AEH)

25.4

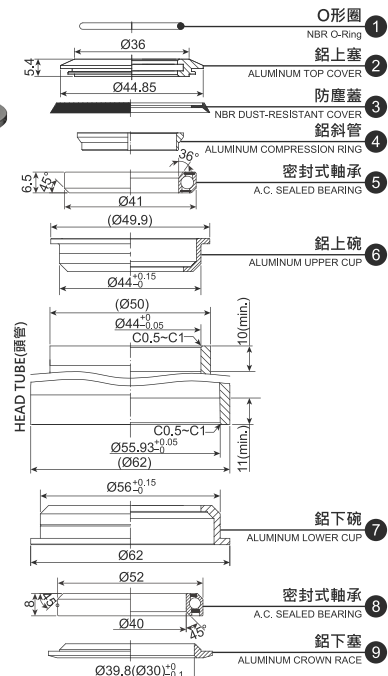

堆積高度 ( STACK HEIGHT ) = 9.5 ± 1 mm

# H385 [H385E]



**H386 [H386E]**

**WEIGHT**

97g

**SIZE**

1.5" Head Tube  
Reduced to 1-1/8"  
Fork Tube  
Semi-Integrated  
Threadless Headset

**SHIS NORM**

ZS44/28.6  
ZS55/39.8 (H385)

**OPTIONAL**

ZS44/28.6  
ZS55/30(H386)

**OPTIONAL**

H385E/H386E:  
Lower Head  
Tube ID/OD.  
=56/62mm

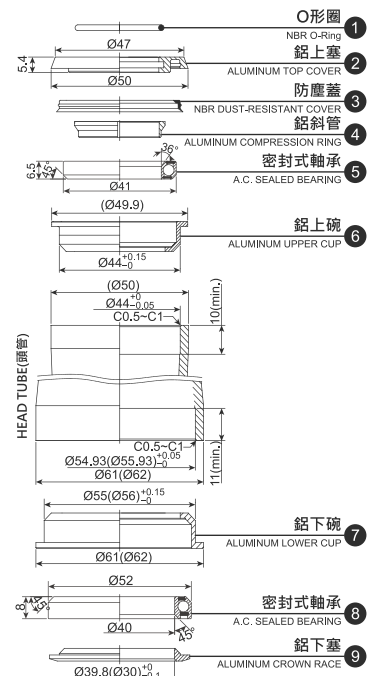

堆積高度 ( STACK HEIGHT ) = 9.5 ± 1 mm

# NECO SEMI-INTEGRATED THREADED HEADSETS

半隱藏式有牙車頭碗 SEMI-INTEGRATED THREADED HEADSETS

## H108 [H108H]



**WEIGHT**

106g

**SIZE**

1" Semi-Integrated Threaded Headset

**DIMENSIONS**

Ø22.2x44/50x27(26.4)

可選配之上塞高度 (TOP COVER IS OPTIONAL)

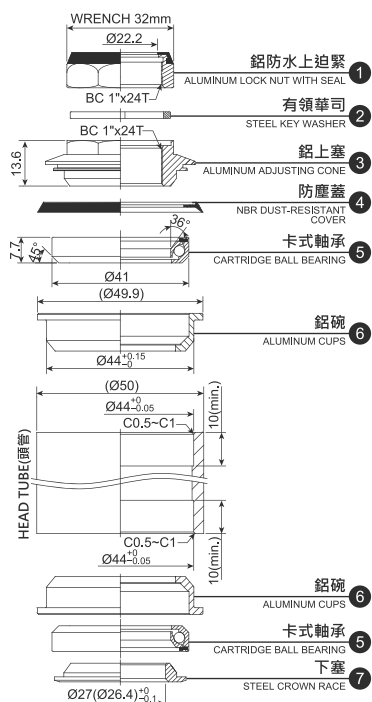
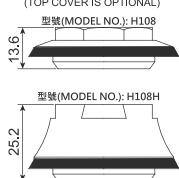

堆積高度 (STACK HEIGHT) = 23.2 ± 1 mm

## H112N



**WEIGHT**

171g

**SIZE**

1-1/8" Semi-Integrated Threaded Headset w/Alloy Cover

**DIMENSIONS**

Ø25.4x44/50x30

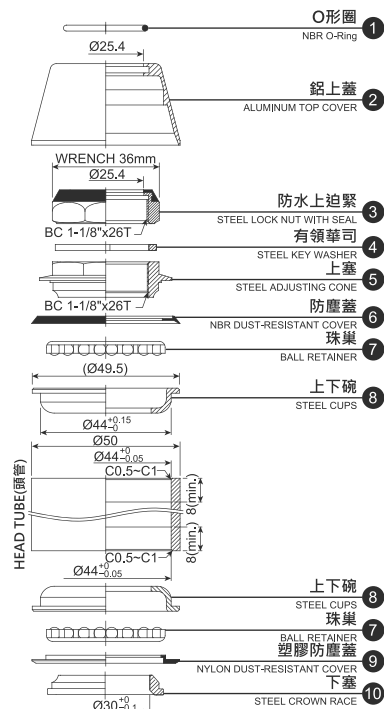

堆積高度 (STACK HEIGHT) = 25.5 ± 1 mm

## H113N



**WEIGHT**

163g

**SIZE**

1-1/8" Semi-Integrated Threaded Headset w/Plastic Cover

**DIMENSIONS**

Ø25.4x44/50x30

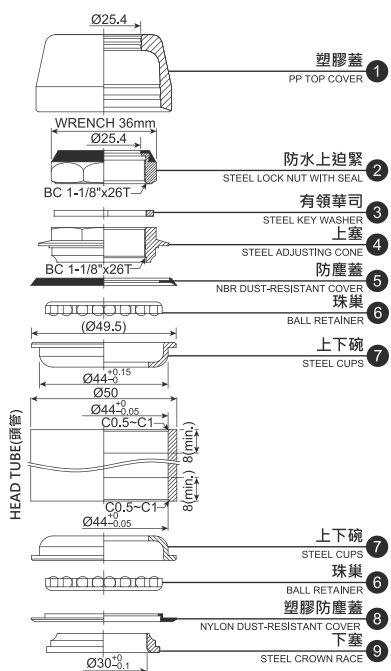

堆積高度 (STACK HEIGHT) = 25.5 ± 1 mm

## H118 [H118H]



**WEIGHT**

103g

**SIZE**

1-1/8" Semi-Integrated Threaded Headset

**DIMENSIONS**

Ø25.4x44/50x30

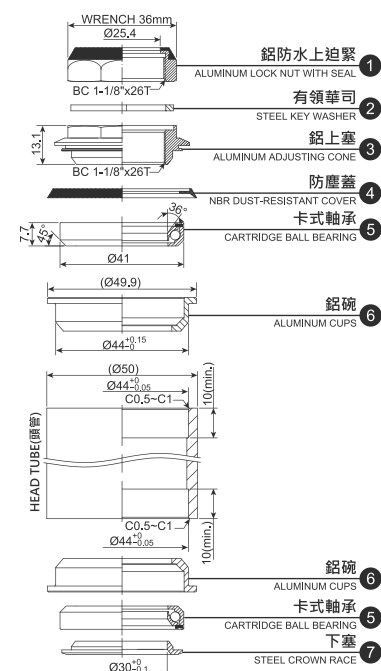
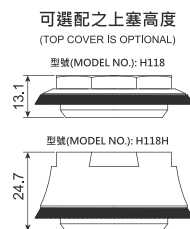

堆積高度 (STACK HEIGHT) = 23.5 ± 1 mm

# H127



**WEIGHT**

128g

**SIZE**

1" Semi-Integrated  
Threaded Headset

**DIMENSIONS**

Ø22.2x41.4/  
46x27(26.4)

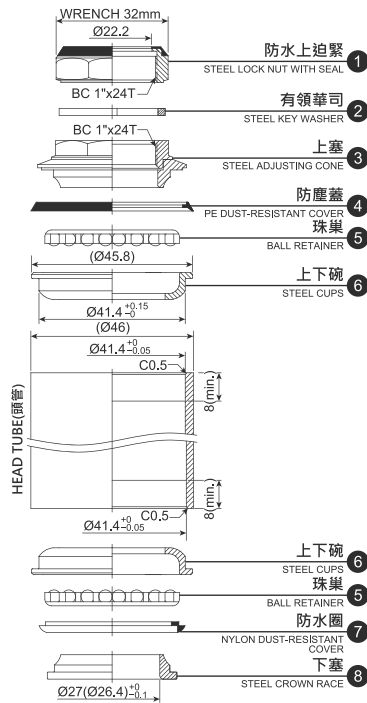

堆積高度 (STACK HEIGHT) = 25.2 ± 1 mm

# H128N



**WEIGHT**

153g

**SIZE**

1-1/8"  
Semi-Integrated  
Threaded Headset

**DIMENSIONS**

Ø25.4x44/50x30

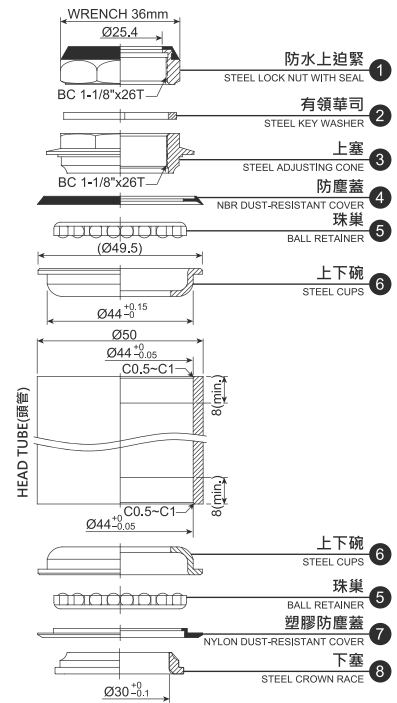

堆積高度 (STACK HEIGHT) = 25.5 ± 1 mm

# H129



**WEIGHT**

155g

**SIZE**

1-1/8"  
Semi-Integrated  
Threaded Headset

**DIMENSIONS**

Ø25.4x44/50x30

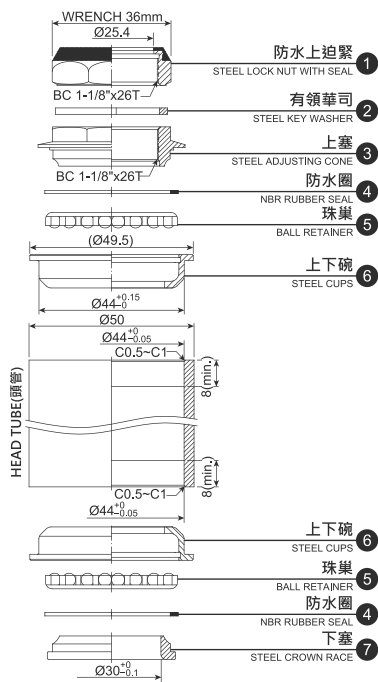

堆積高度 (STACK HEIGHT) = 23.5 ± 1 mm

# H161L [H161H]



**WEIGHT**

H161L: 127g  
H161H: 150g

**SIZE**

1" Semi-Integrated  
Threaded Headset

**DIMENSIONS**

Ø22.2x44/  
50x27(26.4)

可選配之上塞高度  
(ADJUSTING CONE IS OPTIONAL)

型號(MODEL NO.): H161L

型號(MODEL NO.): H161H

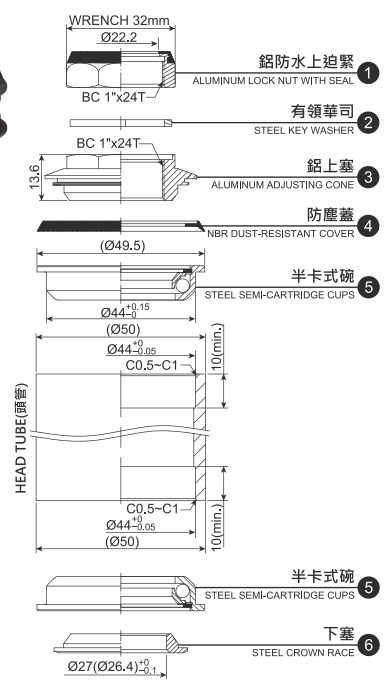
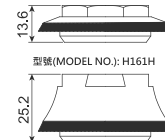

堆積高度 (STACK HEIGHT) = 23.7 ± 1 mm

# NECO SEMI-INTEGRATED THREADED HEADSETS

半隱藏式有牙車頭碗 SEMI-INTEGRATED THREADED HEADSETS

## H168



**WEIGHT**

100g

**SIZE**

1-1/8"  
Semi-Integrated  
Threaded Headset

**DIMENSIONS**

Ø25.4x44/50x30

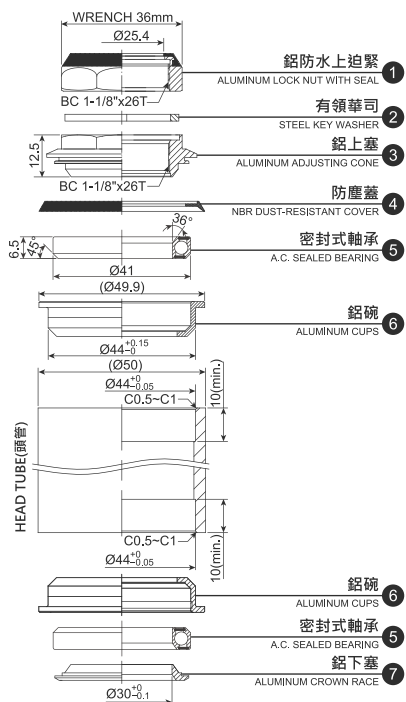

堆積高度 (STACK HEIGHT) = 23.6 ± 1 mm

## H171L [H171H]



**WEIGHT**

H171L: 136g  
H171H: 151g

**SIZE**

1-1/8"  
Semi-Integrated  
Threaded Headset

**DIMENSIONS**

Ø25.4x44/50x30

可選配之上塞高度  
(ADJUSTING CONE IS OPTIONAL)

型號(MODEL NO.): H171L

型號(MODEL NO.): H171H

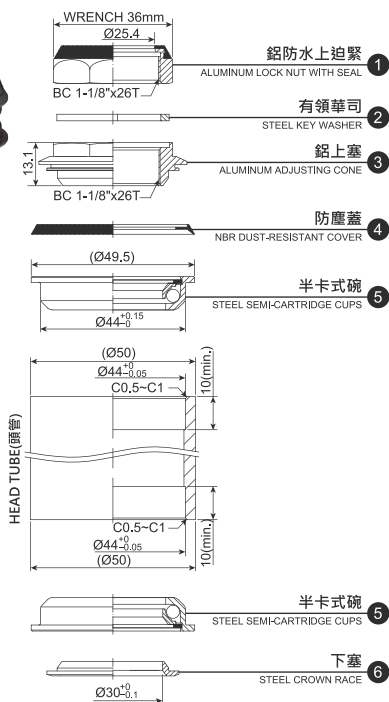

堆積高度 (STACK HEIGHT) = 23.7 ± 1 mm

## H175



**WEIGHT**

159g

**SIZE**

1-1/8"  
Semi-Integrated  
Threaded Headset

**DIMENSIONS**

Ø25.4x44/50x30

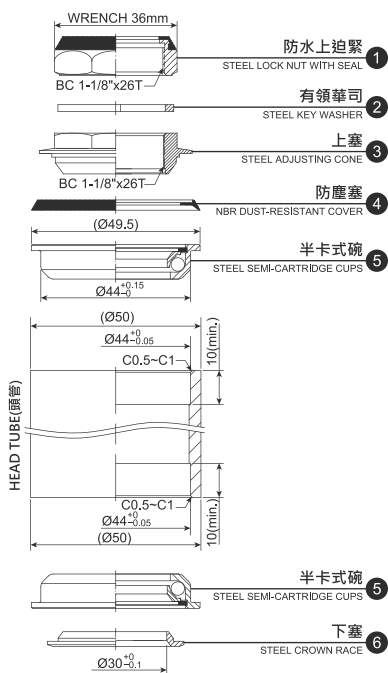

堆積高度 (STACK HEIGHT) = 24.2 ± 1 mm

## H184



**WEIGHT**

130g

**SIZE**

1-1/8"  
Semi-Integrated  
Threaded Headset

**DIMENSIONS**

Ø28.6x44/50x30

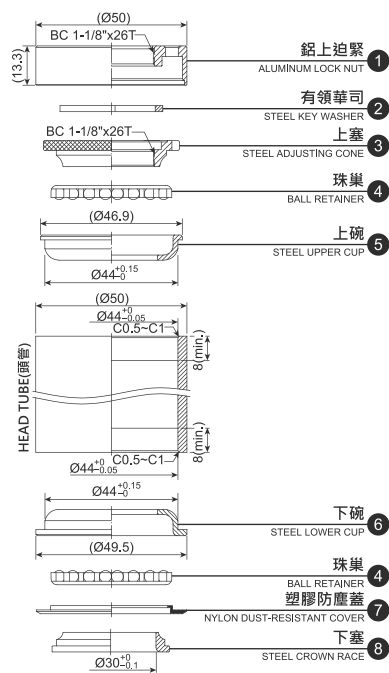

堆積高度 (STACK HEIGHT) = 18 ± 1 mm

# H186



**WEIGHT**

130g

**SIZE**

1-1/8"  
Semi-Integrated  
Threaded Headset

**DIMENSIONS**

Ø28.6x44/50x30

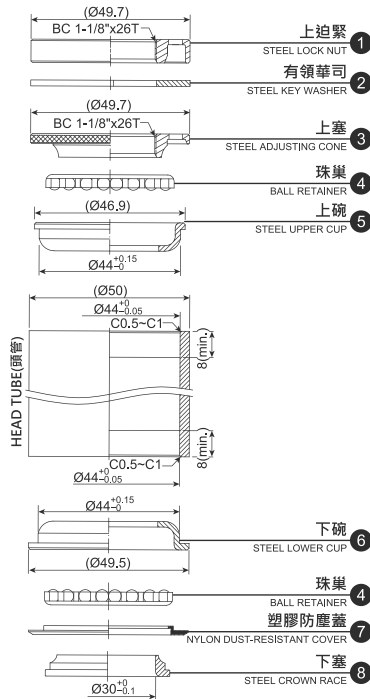

堆積高度 ( STACK HEIGHT ) = 17.7 ±1 mm



# H151BW [1.5"]

1.5" OVERSIZE HEADSET SEALED BEARING LIGHT ALLOY



**WEIGHT**

175.5g

**SIZE**

1-1/2" Threadless  
Headset

**SHIS NORM**

EC49.7/38.1  
EC49.7/39.8

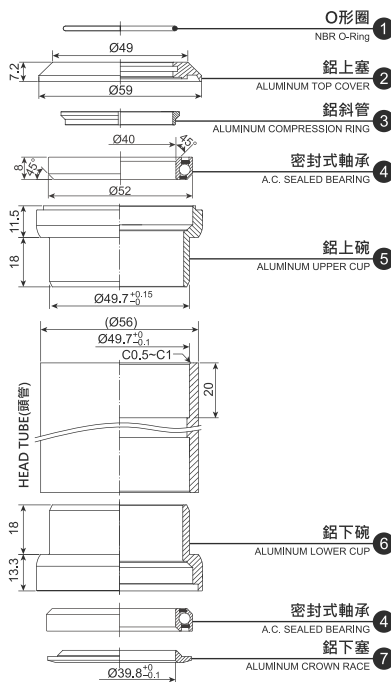

堆積高度 ( STACK HEIGHT ) = 32 ±1 mm

# H153BW

1.5" REDUCED TO 1-1/8" SEALED BEARING LIGHT ALLOY



**WEIGHT**

194g

**SIZE**

1.5" Head Tube Reduced  
to 1-1/8" Fork Tube  
Semi-Integrated  
Threadless Headset

**SHIS NORM**

EC49.7/28.6  
EC49.7/30

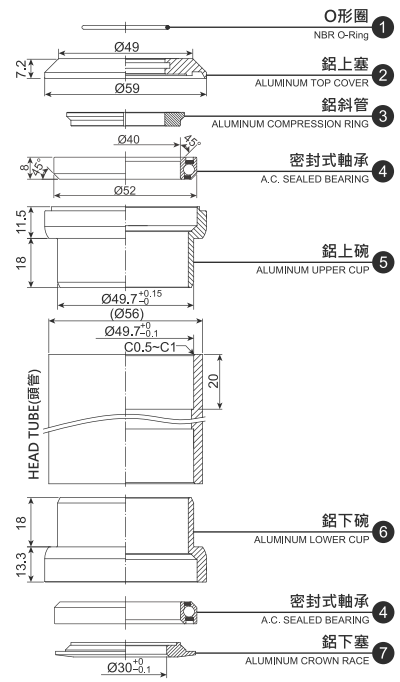

堆積高度 ( STACK HEIGHT ) = 32 ±1 mm

# NECO EXTERNAL CUP THREADLESS HEADSETS

外露式無牙車頭碗 EXTERNAL CUP THREADLESS HEADSETS

## H252



**WEIGHT**

98.6g

**SIZE**

1" Threadless Headset

**SHIS NORM**

EC30/25.4  
EC30/27(26.4)

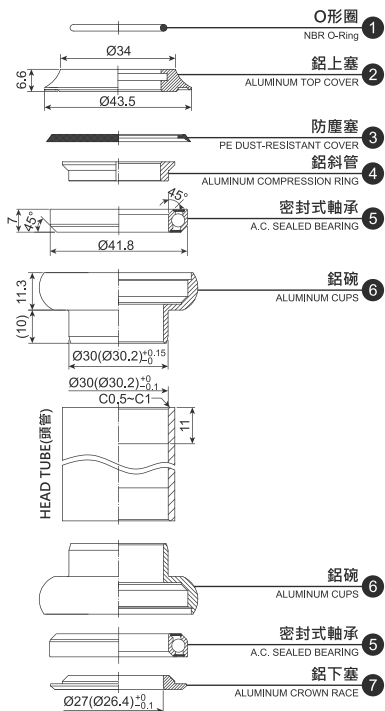

堆積高度 ( STACK HEIGHT ) = 29 ±1 mm

## H282



OPTIONAL H282O

**WEIGHT**

95g

**SIZE**

1-1/8" Threadless Headset

**SHIS NORM**

EC34/28.6  
EC34/30

**OPTIONAL**

H282O:EC34/28.6  
EC34/30  
Height:27±1mm

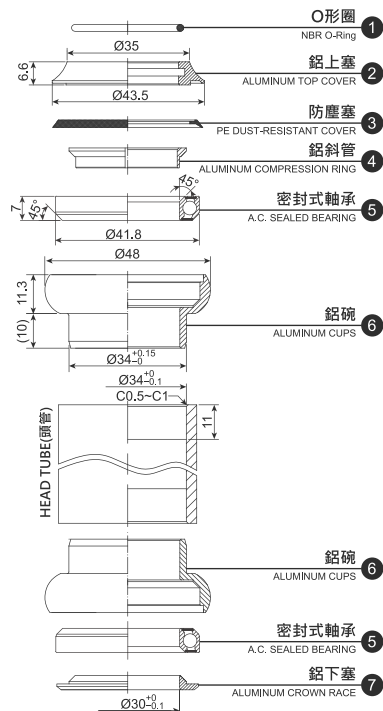

堆積高度 ( STACK HEIGHT ) = 29 ±1 mm

## H370



**WEIGHT**

115g

**SIZE**

1-1/8" Threadless Headset

**SHIS NORM**

EC34/28.6  
EC34/30

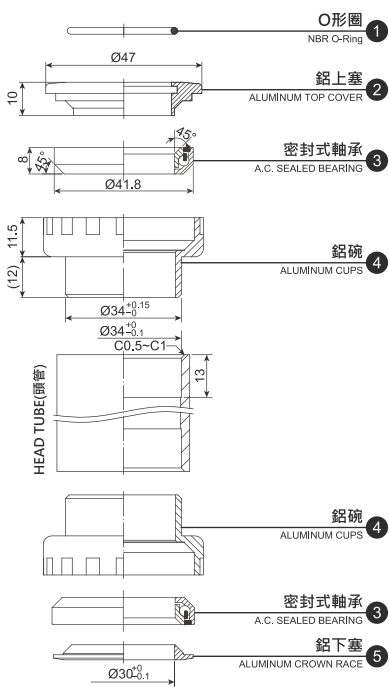

堆積高度 ( STACK HEIGHT ) = 28.3 ±1 mm

## H610



**WEIGHT**

104g

**SIZE**

1" Threadless Headset

**SHIS NORM**

EC30/25.4  
EC30/27(26.4)

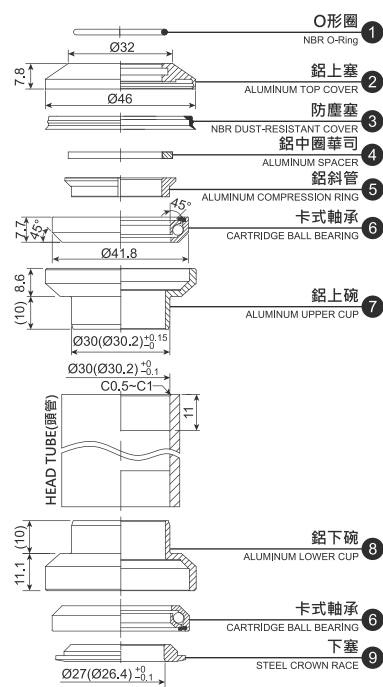

堆積高度 ( STACK HEIGHT ) = 29 ±1 mm

# H626



**WEIGHT**

103.1g

**SIZE**

1" Threadless Headset

**SHIS NORM**

EC30/25.4  
EC30/27(26.4)

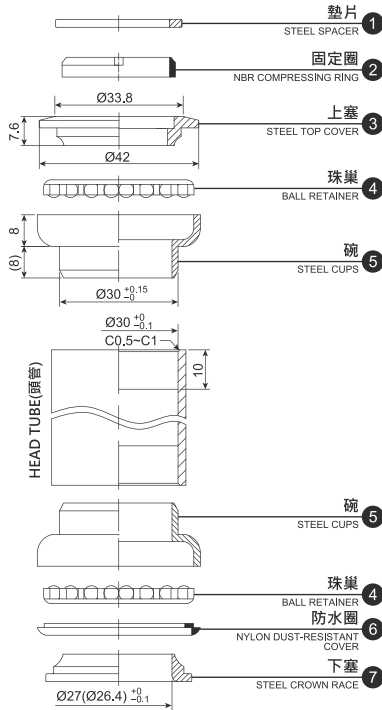

堆積高度 (STACK HEIGHT) = 24.5 ± 1 mm

# H673



**WEIGHT**

92g

**SIZE**

1" Threadless Headset

**SHIS NORM**

EC30/25.4  
EC30/27(26.4)

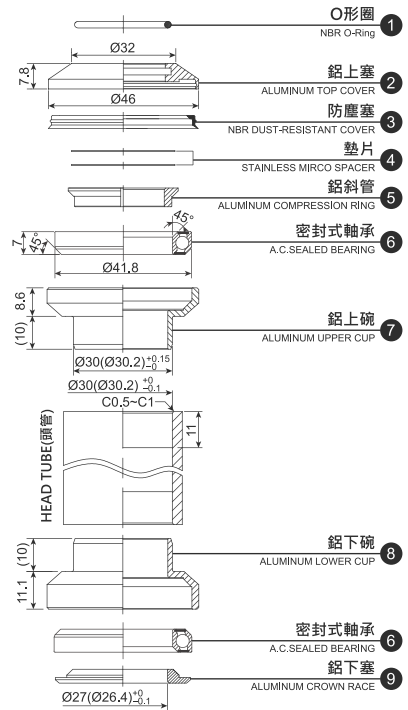

堆積高度 (STACK HEIGHT) = 29.5 ± 1 mm

# H701

Smart design that gives an integrated style-like look



**WEIGHT**

92g

**SIZE**

1-1/8" Threadless Headset

**SHIS NORM**

EC34/28.6  
EC34/30

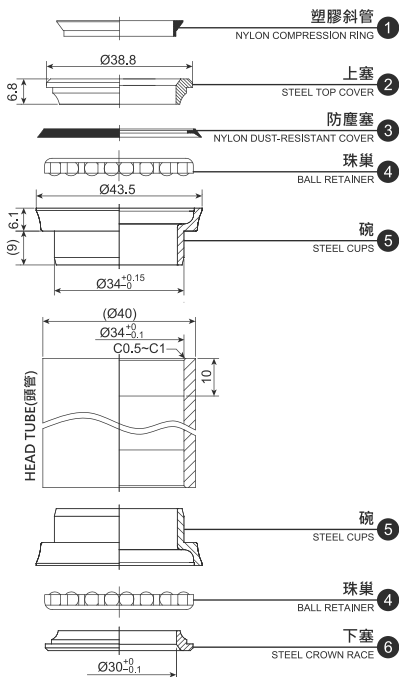

堆積高度 (STACK HEIGHT) = 20 ± 1 mm

# H705PS



**WEIGHT**

120g

**SIZE**

1-1/8" Reduced to 1" Threadless Steerer

**SHIS NORM**

EC34/25.4  
EC34/30

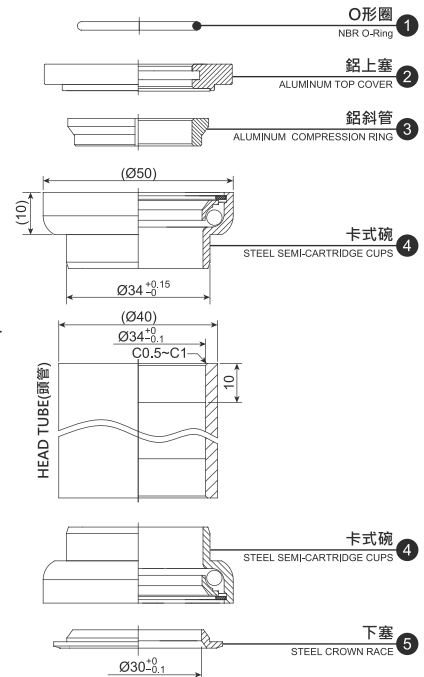

堆積高度 (STACK HEIGHT) = 28.3 ± 1 mm

# NECO EXTERNAL CUP THREADLESS HEADSETS

外露式無牙車頭碗 EXTERNAL CUP THREADLESS HEADSETS

## H706 [H706M]

Smart Design That Gives An Integrated Style-Like Look



**WEIGHT**

95g

**SIZE**

1-1/8" Threadless Headset

**SHIS NORM**

EC34/28.6  
EC34/30

可選配之上塞高度  
(TOP COVER IS OPTIONAL)  
型號(MODEL NO.): H706

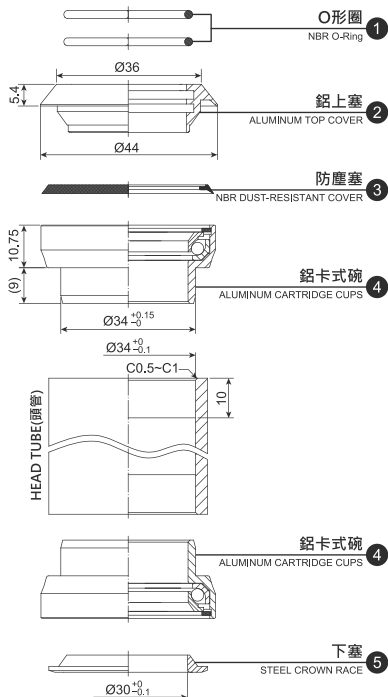
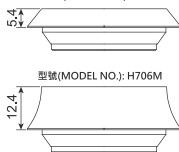

堆積高度 (STACK HEIGHT) = 28.6 ± 1 mm

## H711



**WEIGHT**

112g

**SIZE**

1-1/8" Threadless Headset

**SHIS NORM**

EC34/28.6  
EC34/30

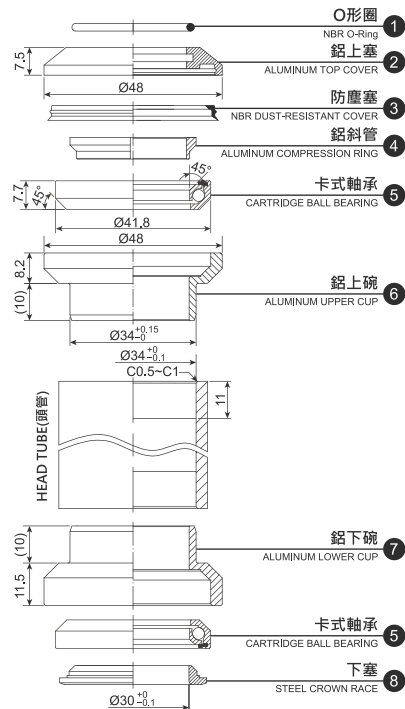

堆積高度 (STACK HEIGHT) = 29 ± 1 mm

## H773



**WEIGHT**

102g

**SIZE**

1-1/8" Threadless Headset

**SHIS NORM**

EC34/28.6  
EC34/30

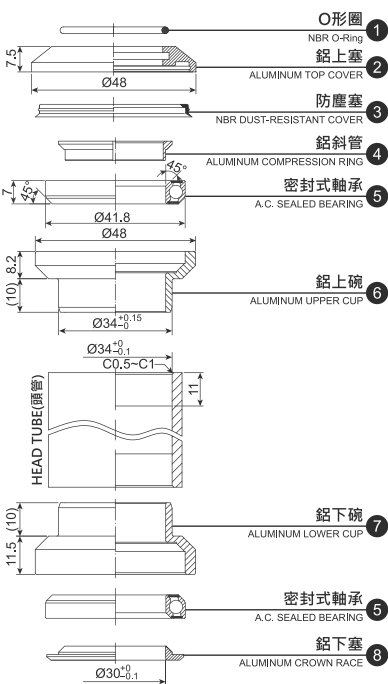

堆積高度 (STACK HEIGHT) = 29 ± 1 mm

## H773L



**WEIGHT**

151g

**SIZE**

1.5" Head Tube Reduced to 1-1/8"

**SHIS NORM**

EC34/28.6  
EC49.7/39.8(30)

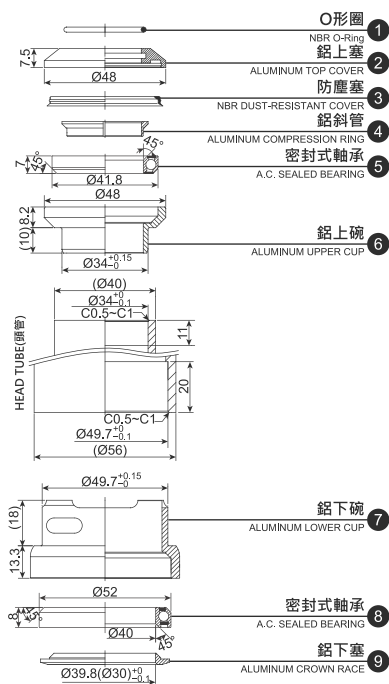

堆積高度 (STACK HEIGHT) = 30.4 ± 1 mm

# H825



**WEIGHT**

114g

**SIZE**

1" Threadless Headset

**SHIS NORM**

EC30/25.4  
EC30/27(26.4)

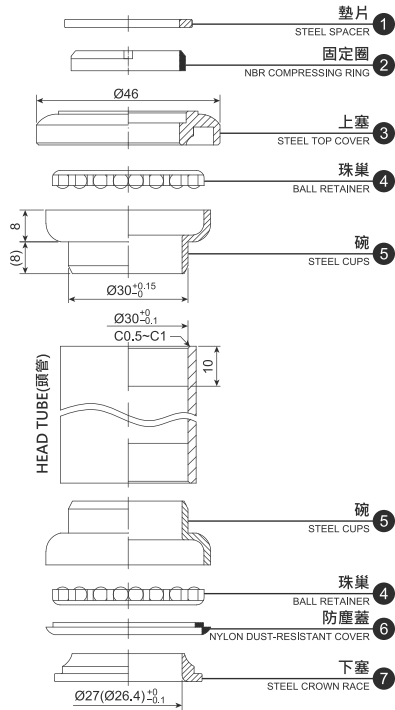

堆積高度 ( STACK HEIGHT ) = 25±1 mm

# H827W



**WEIGHT**

102g

**SIZE**

1" Threaded Headset

**SHIS NORM**

EC30/25.4  
EC30/27(26.4)

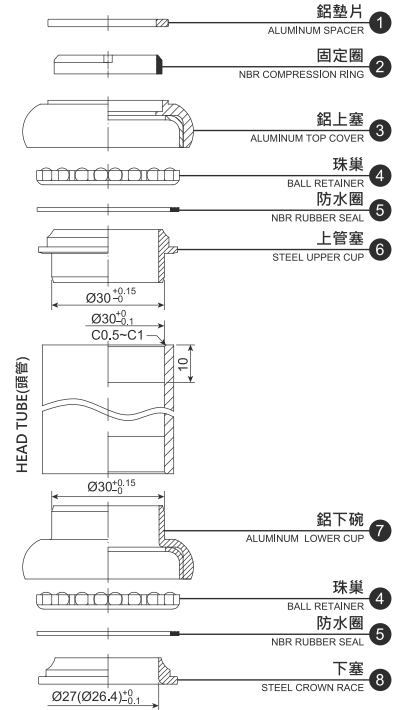

堆積高度 ( STACK HEIGHT ) = 28.2±1 mm

# H845



**WEIGHT**

169g

**SIZE**

1-1/8" Threadless Headset

**SHIS NORM**

EC34/28.6  
EC34/30

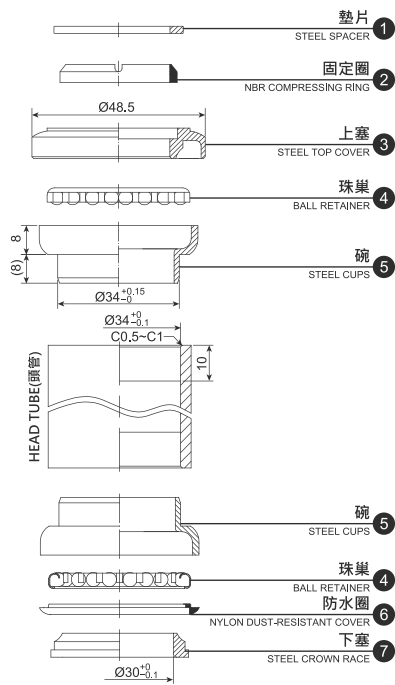

堆積高度 ( STACK HEIGHT ) = 26.5 ± 1 mm

# H846



**WEIGHT**

144g

**SIZE**

1-1/8" Threadless Headset

**SHIS NORM**

EC34/28.6  
EC34/30

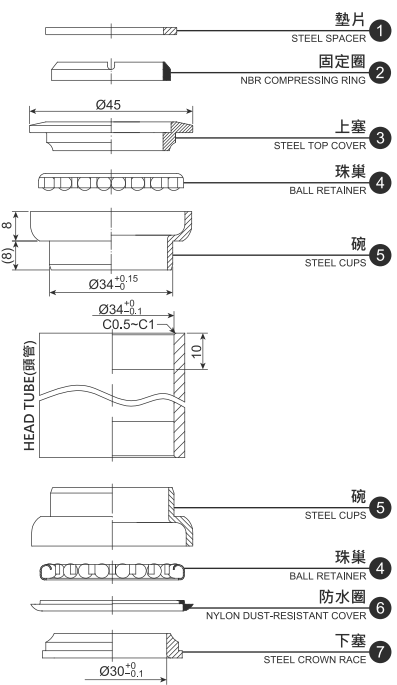

堆積高度 ( STACK HEIGHT ) = 25 ± 1 mm

# NECO EXTERNAL CUP THREADLESS HEADSETS

外露式無牙車頭碗 EXTERNAL CUP THREADLESS HEADSETS

## H847W



**WEIGHT**

125g

**SIZE**

1-1/8" Threadless Headset

**SHIS NORM**

EC34/28.6  
EC34/30

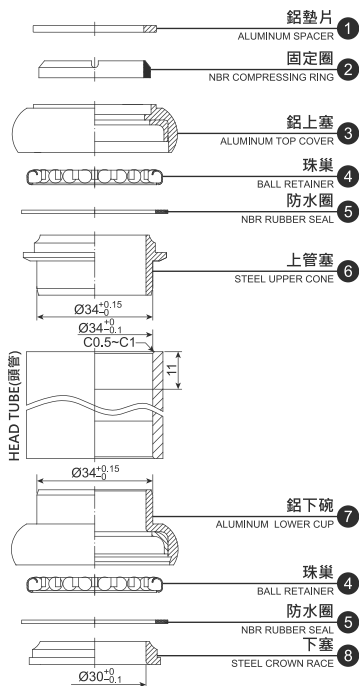

堆積高度 (STACK HEIGHT) = 31±1 mm

## H852



**WEIGHT**

105g

**SIZE**

1-1/8" Threadless Headset

**SHIS NORM**

EC34/28.6  
EC34/30

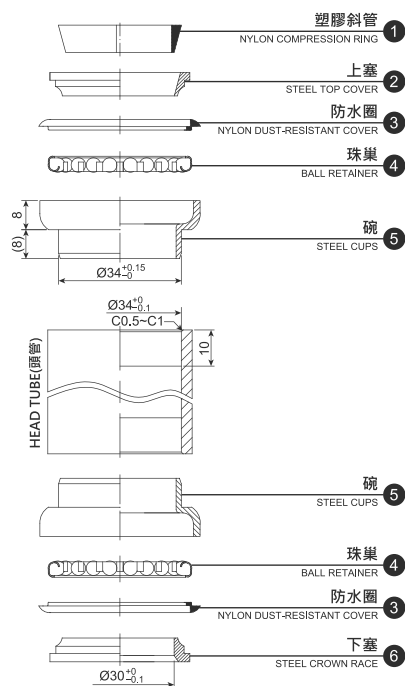

堆積高度 (STACK HEIGHT) = 22±1 mm

## H854



**WEIGHT**

120g

**SIZE**

1-1/8" Threadless Headset

**SHIS NORM**

EC34/28.6  
EC34/30

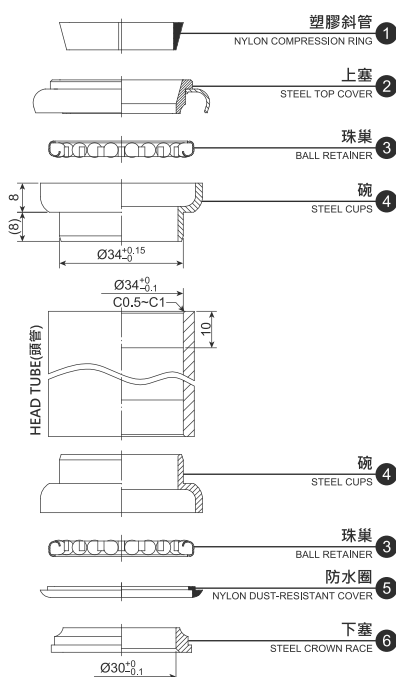

堆積高度 (STACK HEIGHT) = 25±1 mm

## H855 [H826]



**WEIGHT**

163g

**SIZE**

1-1/8" Threadless Headset

**SHIS NORM**

EC34/28.6  
EC34/30

**OPTIONAL**

H826 EC30/25.4  
EC30/27(26.4)  
STACK HEIGHT = 25.6mm

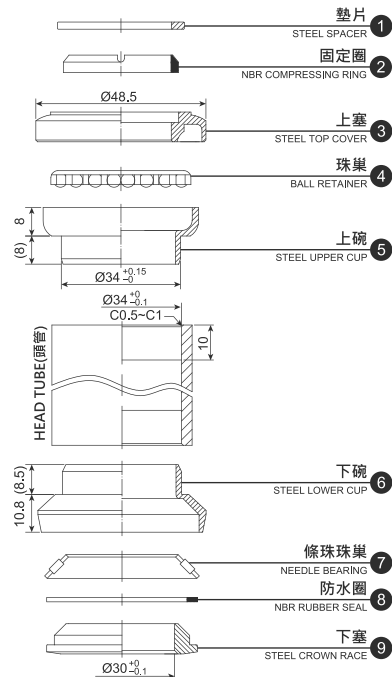

堆積高度 (STACK HEIGHT) = 28.4 ±1 mm

# H867EW [H236EW]



**WEIGHT**

127g

**SIZE**

1-1/8" Threadless Headset

**SHIS NORM**

EC34/28.6  
EC34/30

**OPTIONAL**

H236EW EC30/25.4  
EC30/27(26.4)  
STACK HEIGHT = 28.2mm

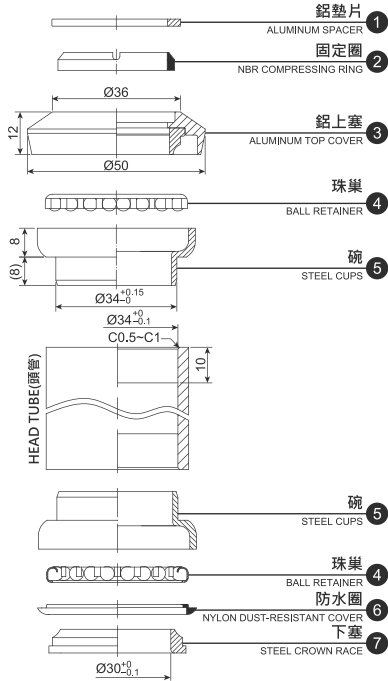

堆積高度 (STACK HEIGHT) = 28±1 mm

# H878



**WEIGHT**

142g

**SIZE**

1-1/8" Threadless Headset

**SHIS NORM**

EC34/28.6  
EC34/30

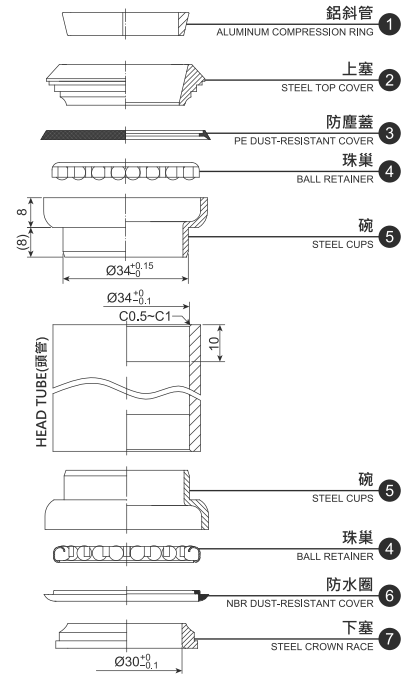

堆積高度 (STACK HEIGHT) = 26.5±1 mm

# H879

BIG LOWER CUP FOR HEAVY DUTY



**WEIGHT**

180g

**SIZE**

1-1/8" Threadless Headset

**SHIS NORM**

EC34/28.6  
EC34/30

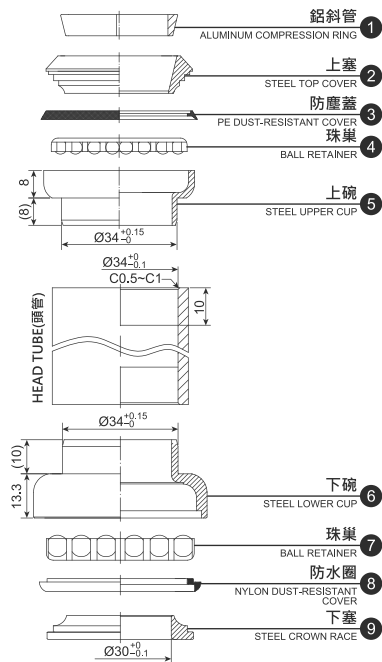

堆積高度 (STACK HEIGHT) = 30.4±1 mm



# H130 130° 1" SAFETY HEADSET



**WEIGHT**

127g

**SIZE**

1" Threaded Safety Headset

**DIMENSIONS**

Ø22.2x30x27

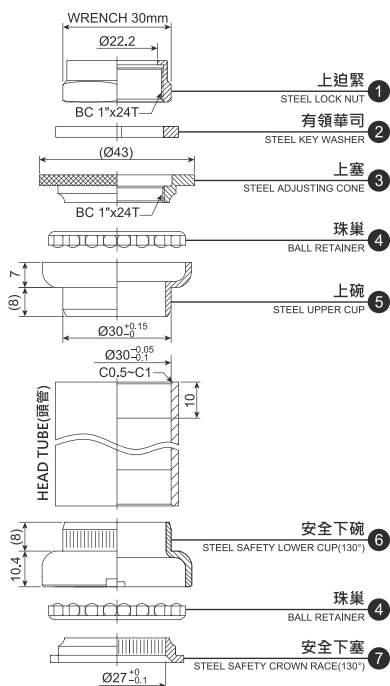

堆積高度 (STACK HEIGHT) = 34.5 ± 1 mm

# H134 130° 1" SAFETY HEADSET



**WEIGHT**

116g

**SIZE**

1" Threadless Safety Headset

**SHIS NORM**

EC30/25.4  
 EC30/27

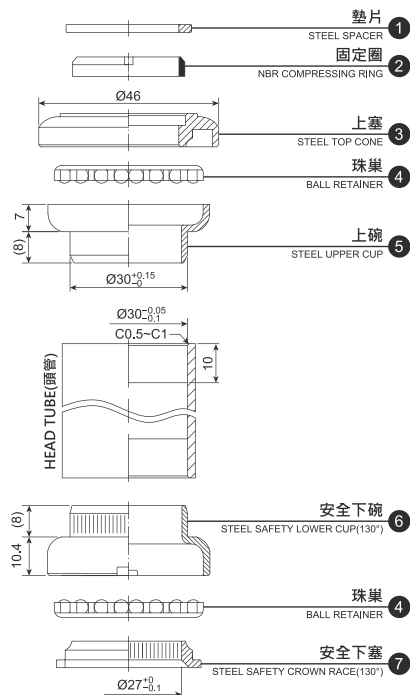

堆積高度 (STACK HEIGHT) = 25.5 ± 1 mm

# H135 130° 1-1/8" SAFETY HEADSET



**WEIGHT**

142g

**SIZE**

1-1/8" Threadless Safety Headset

**SHIS NORM**

EC34/28.6  
 EC34/30

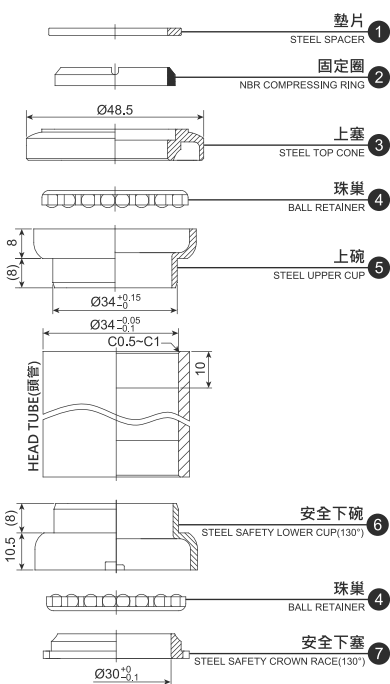

堆積高度 (STACK HEIGHT) = 27.5 ± 1 mm

# H139 130° 1" SAFETY HEADSET



**WEIGHT**

136g

**SIZE**

1" Threaded Safety Headset

**DIMENSIONS**

Ø22.2x30x27

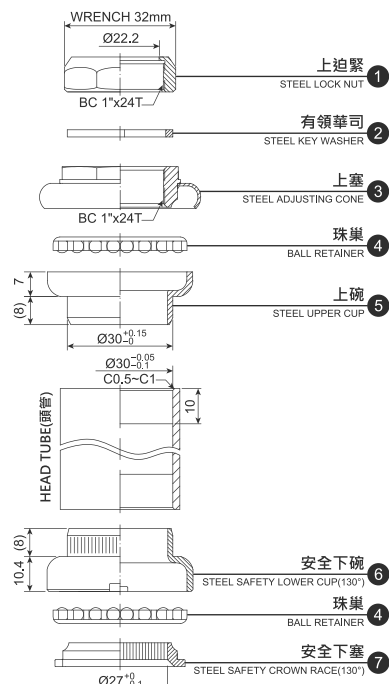

堆積高度 (STACK HEIGHT) = 37 ± 1 mm

# H140 130° 1-1/8" SAFETY HEADSET



**WEIGHT**

164g

**SIZE**

1-1/8" Threaded Safety Headset

**DIMENSIONS**

Ø25.4x34x30

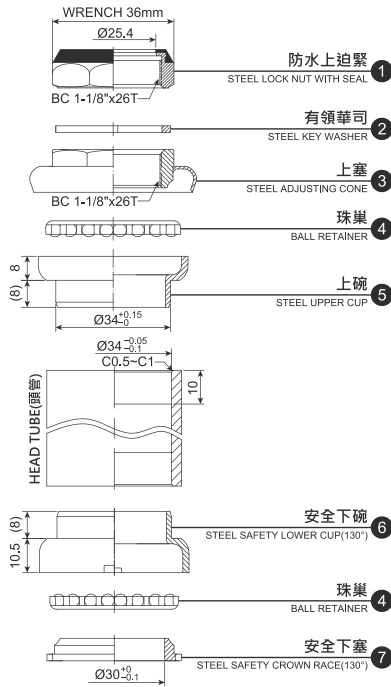

堆積高度 ( STACK HEIGHT ) = 38.5 ± 1 mm

# H128-130 130° 1-1/8" SAFETY SEMI-INTEGRATED HEADSET



**WEIGHT**

154g

**SIZE**

1-1/8" Semi-Integrated Threaded Safety Headset

**DIMENSIONS**

Ø25.4x44/50x30

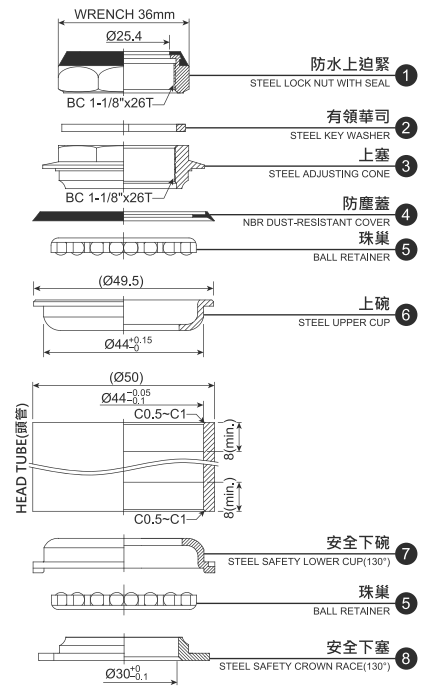

堆積高度 ( STACK HEIGHT ) = 26.5 ± 1 mm

# H128-130SA 130° 1-1/8" SAFETY SEMI-INTEGRATED HEADSET



**WEIGHT**

164.8g

**SIZE**

1-1/8" Semi-Integrated Threadless Safety Headset

**DIMENSIONS**

Ø25.4x44/50x30

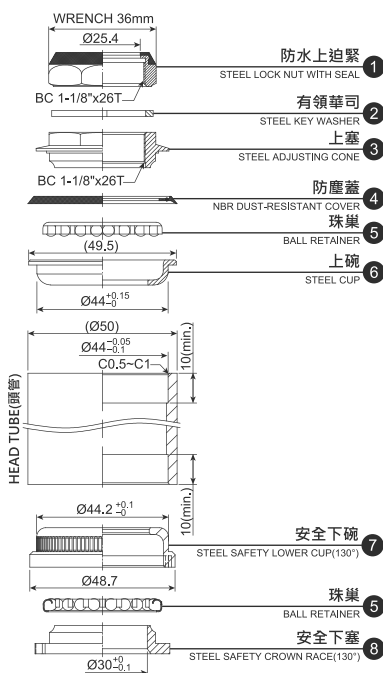

堆積高度 ( STACK HEIGHT ) = 26.9 ± 1 mm

# H146-130SB 130° 1-1/8" SAFETY SEMI-INTEGRATED HEADSET



**WEIGHT**

108.1g

**SIZE**

1-1/8" Semi-Integrated Threadless Safety Headset

**SHIS NORM**

ZS44/28.6  
ZS44/30

可選配之上塞高度 (TOP COVER IS OPTIONAL)

型號 (MODEL NO.): H146M-130SB

型號 (MODEL NO.): H146M-130SB

型號 (MODEL NO.): H146H-130SB

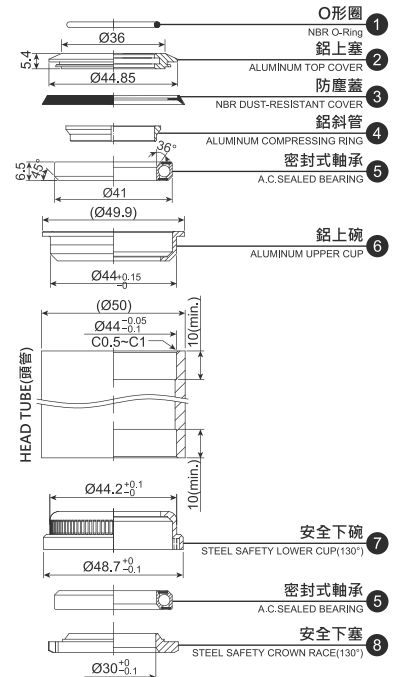

堆積高度 ( STACK HEIGHT ) = 12.1 ± 1 mm

# H148-130 130° 1-1/8" SAFETY SEMI-INTEGRATED HEADSET



**WEIGHT**

100.8g

**SIZE**

1-1/8"  
Semi-Integrated  
Threadless Safety  
Headset

**SHIS NORM**

ZS44/28.6  
ZS44/30

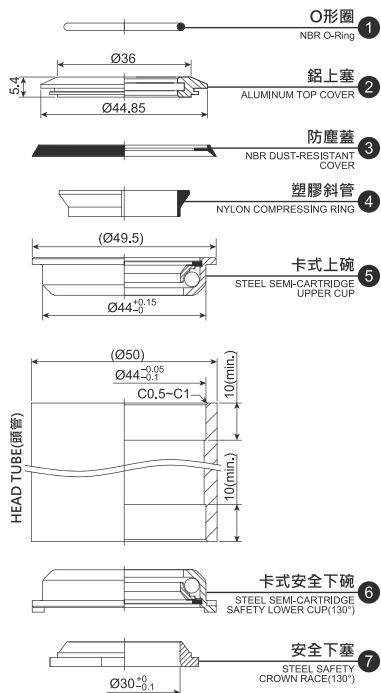

堆積高度 (STACK HEIGHT) = 11.6 ± 1 mm

# H148-130SA 130° 1-1/8" SAFETY SEMI-INTEGRATED HEADSET



**WEIGHT**

105g

**SIZE**

1-1/8"  
Semi-Integrated  
Threaded Safety  
Headset

**DIMENSIONS**

ZS44/28.6  
ZS44/30

可選配之上塞高度  
(TOP COVER IS OPTIONAL)

型號(MODEL NO.): H148-130SA

型號(MODEL NO.): H148M-130SA

型號(MODEL NO.): H148H-130SA

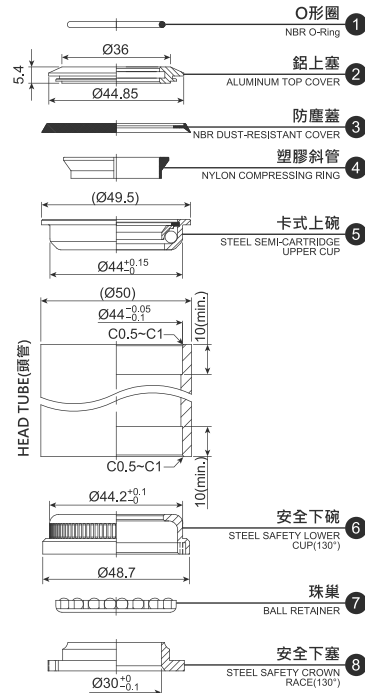

堆積高度 (STACK HEIGHT) = 12.8 ± 1 mm

# H153-1SB 130° 1.5" SAFETY SEMI-INTEGRATED HEADSET

H153E-1SB



**WEIGHT**

224.9g

**SIZE**

1.5" Head Tube  
Reduce to 1-1/8"  
Fork Tube  
Semi-Integrated  
Threadless Safety  
Headset

**SHIS NORM**

ZS55/28.6  
ZS55/39.8(30)

**OPTIONAL**

H153E-1SB  
ZS56/28.6  
ZS56/39.8(30)

可選配之上塞高度  
(TOP COVER IS OPTIONAL)

型號(MODEL NO.): H153M-1SB(H153ME-1SB)



堆積高度(STACK HEIGHT)=23.9±1mm

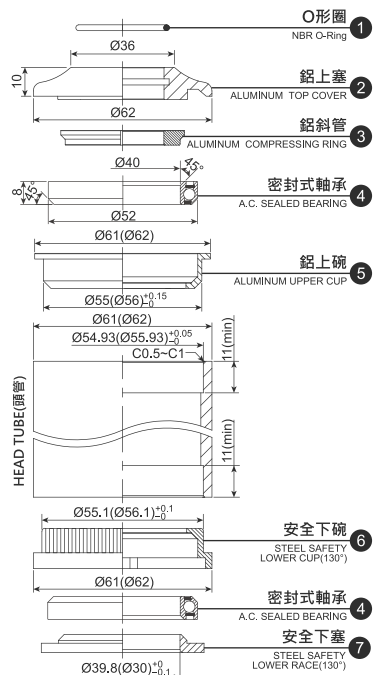

堆積高度 (STACK HEIGHT) = 18.9 ± 1 mm

# H158-SA 130° 1.5" SAFETY SEMI-INTEGRATED HEADSET

H158ESA



**WEIGHT**

258.5g

**SIZE**

1.5" Head Tube  
Reduce to 1-1/8"  
Fork Tube  
Semi-Integrated  
Threaded Safety  
Headset

**DIMENSIONS**

Ø25.4x55  
/61x39.8(30)

**OPTIONAL**

H158ESA  
Ø25.4x56  
/62x39.8(30)

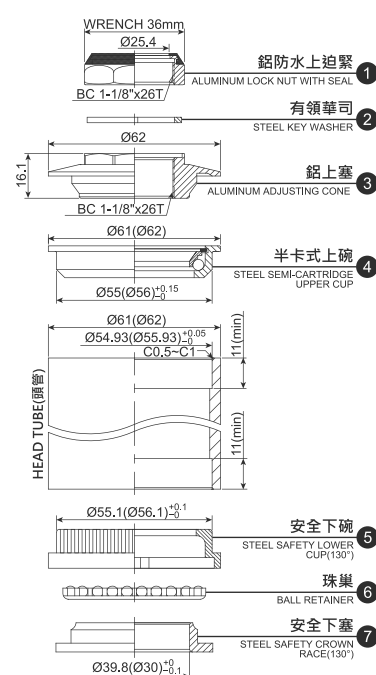

堆積高度 (STACK HEIGHT) = 27.2 ± 1 mm

# H382S-152SB



**WEIGHT**

113.3g

**SIZE**

1.5"Head Tube  
Reduced To 1-1/8"  
Fork Tube Integrated  
Threadless Headset

**SHIS NORM**

IS52.2/28.6  
ZS52/30

可選配之上塞高度  
(TOP COVER IS OPTIONAL)  
型號(MODEL NO.): H382SM-152SB

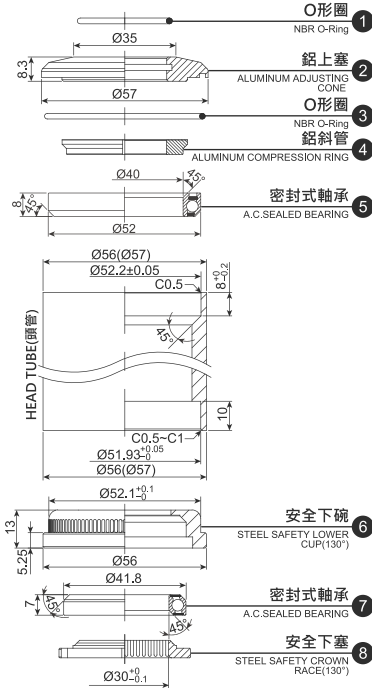
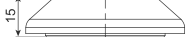

堆積高度 (STACK HEIGHT) = 13.7 ± 1 mm

# H231



**WEIGHT**

116.5g

**SIZE**

1-1/8" x 26T

**DIMENSIONS**

Ø28.6x34x30

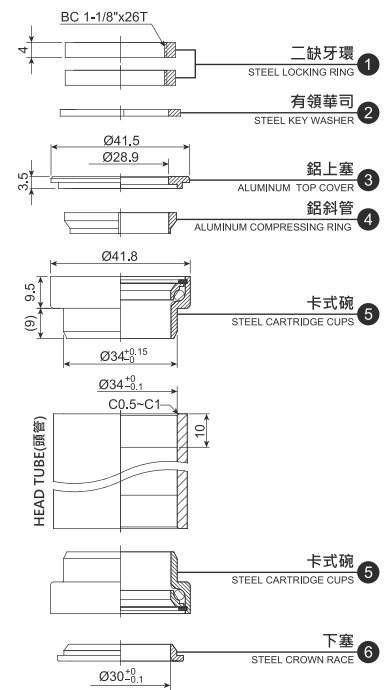

堆積高度 (STACK HEIGHT) = 34 ± 1 mm

# H617



**WEIGHT**

101.8g

**SIZE**

1"x24T

**DIMENSIONS**

Ø22.2x30x27(26.4)

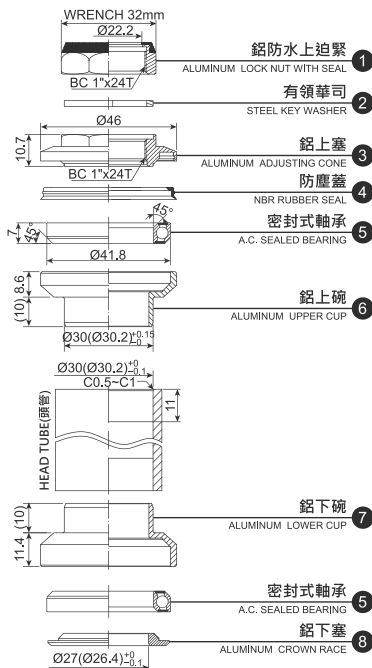

堆積高度 (STACK HEIGHT) = 40.5 ± 1 mm

# H671



**WEIGHT**

117g

**SIZE**

1"x24T

**DIMENSIONS**

Ø22.2x30x27(26.4)

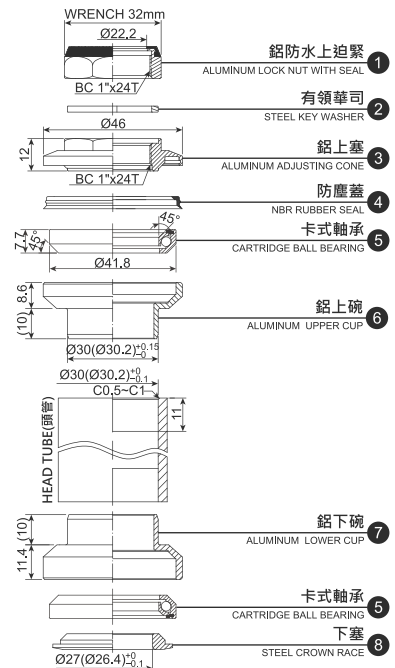

堆積高度 (STACK HEIGHT) = 40.5 ± 1 mm

# NECO EXTERNAL CUP THREADED HEADSETS

外露式有牙車頭碗 EXTERNAL CUP THREADED HEADSETS

## H717



**WEIGHT**

116g

**SIZE**

1-1/8"x26T

**DIMENSIONS**

Ø25.4x34x30

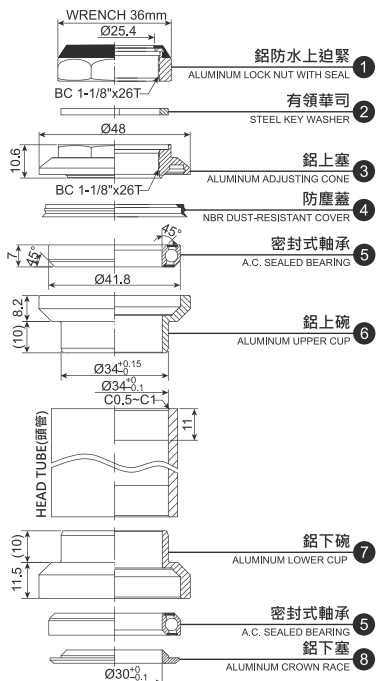

堆積高度 ( STACK HEIGHT ) = 40.5 ± 1 mm

## H771



**WEIGHT**

120g

**SIZE**

1-1/8"x26T

**DIMENSIONS**

Ø25.4x34x30

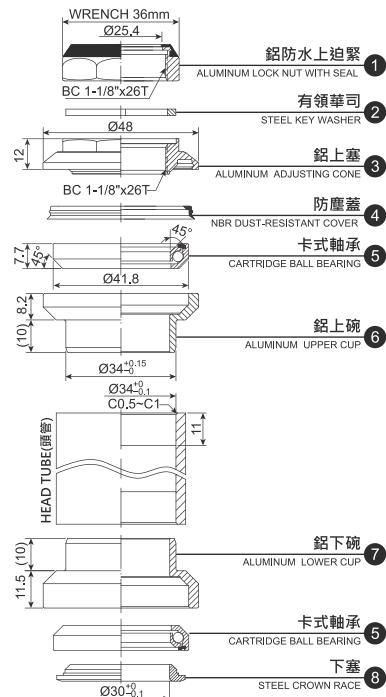

堆積高度 ( STACK HEIGHT ) = 40.8 ± 1 mm

## H800K



**WEIGHT**

123g

**SIZE**

1"x24T

**DIMENSIONS**

Ø22.2x30x27(26.4)

**OPTIONAL**

H800D Plain Washer (w/o nose)  
H800T Threaded Washer  
H800C Semi-Cartridge Cups

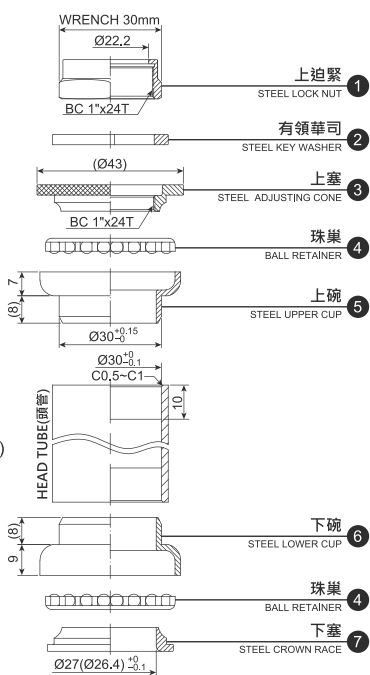

堆積高度 ( STACK HEIGHT ) = 34.3 ± 1 mm

## H801K



**WEIGHT**

139g

**SIZE**

1"x24T

**DIMENSIONS**

Ø22.2x30x27(26.4)

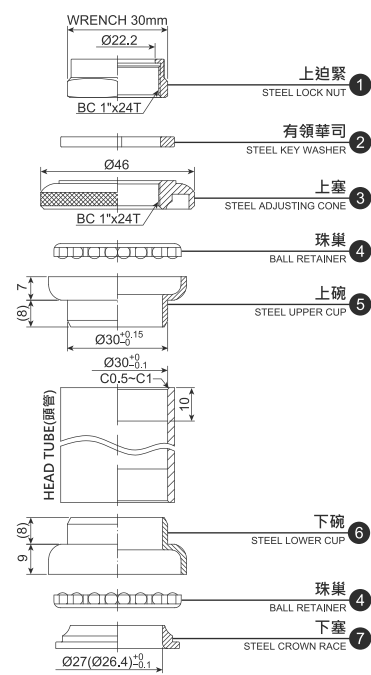

堆積高度 ( STACK HEIGHT ) = 36 ± 1 mm

# H802AK



**WEIGHT**

150g

**SIZE**

1"x24T

**DIMENSIONS**

Ø21.1x32.5x27

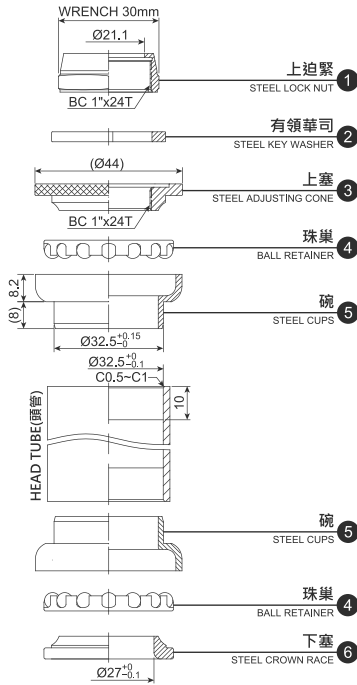

堆積高度 (STACK HEIGHT) = 36 ± 1 mm

# H806



**WEIGHT**

144.7g

**SIZE**

1"x24T

**DIMENSIONS**

Ø22.2x30x27(26.4)

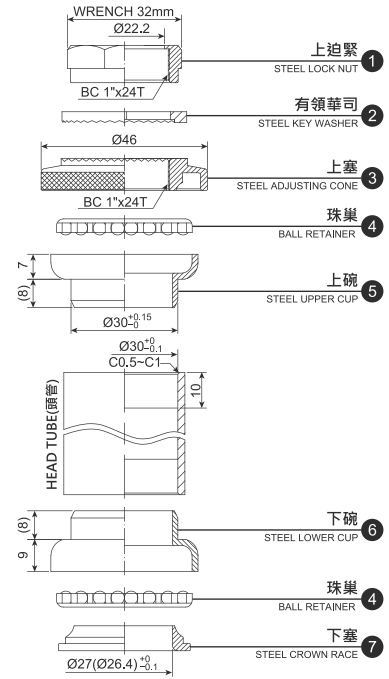

堆積高度 (STACK HEIGHT) = 35 ± 1 mm

# H807W



**WEIGHT**

115g

**SIZE**

1"x24T

**DIMENSIONS**

Ø22.2x30x27(26.4)

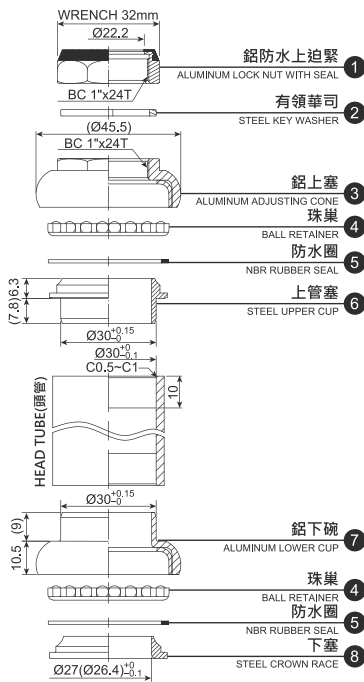

堆積高度 (STACK HEIGHT) = 39.5 ± 1 mm

# H815W



**WEIGHT**

145g

**SIZE**

1-1/8"x26T

**DIMENSIONS**

Ø25.4x34x30

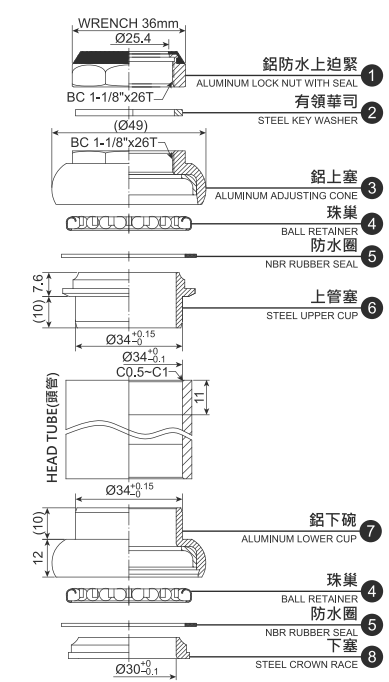

堆積高度 (STACK HEIGHT) = 43 ± 1 mm

# NECO EXTERNAL CUP THREADED HEADSETS

外露式有牙車頭碗 EXTERNAL CUP THREADED HEADSETS

## H831



**WEIGHT**

134g

**SIZE**

1"x24T

**DIMENSIONS**

Ø22.2x30x27(26.4)

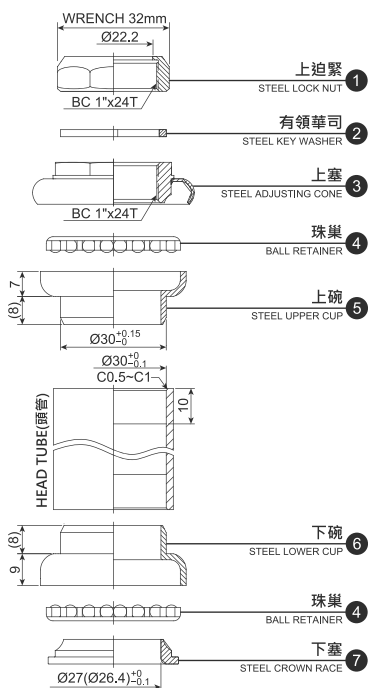

堆積高度 ( STACK HEIGHT ) = 36.5 ± 1 mm

## H831CW



**WEIGHT**

140.1g

**SIZE**

1"x24T

**DIMENSIONS**

Ø22.2x30x27(26.4)

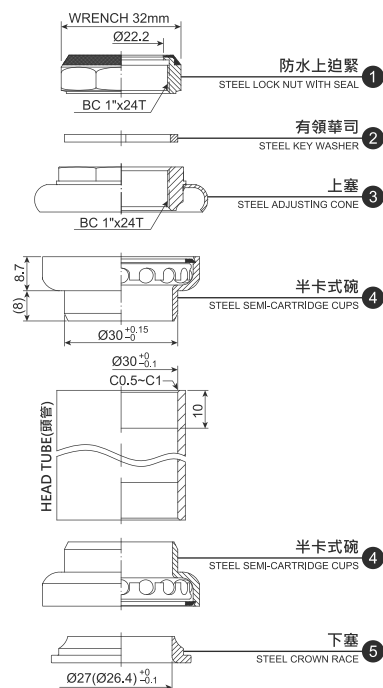

堆積高度 ( STACK HEIGHT ) = 36.5 ± 1 mm

## H831SW



**WEIGHT**

134g

**SIZE**

1"x24T

**DIMENSIONS**

Ø22.2x30x27(26.4)

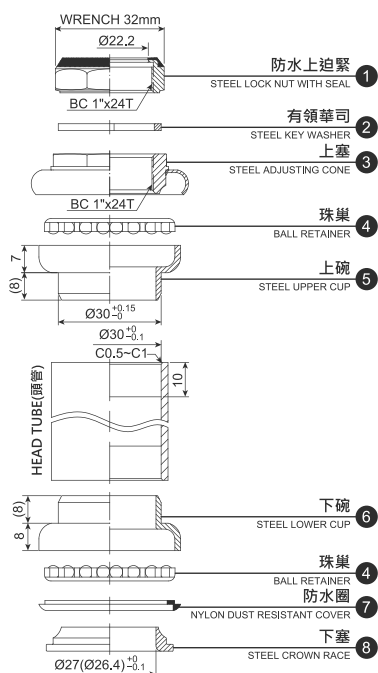

堆積高度 ( STACK HEIGHT ) = 36.5 ± 1 mm

## H833K



**WEIGHT**

127.8g

**SIZE**

1-1/8" Head Tube  
Reduced to 1" Fork  
Tube Threaded  
Headset

**DIMENSIONS**

Ø22.2x34/27(26.4)

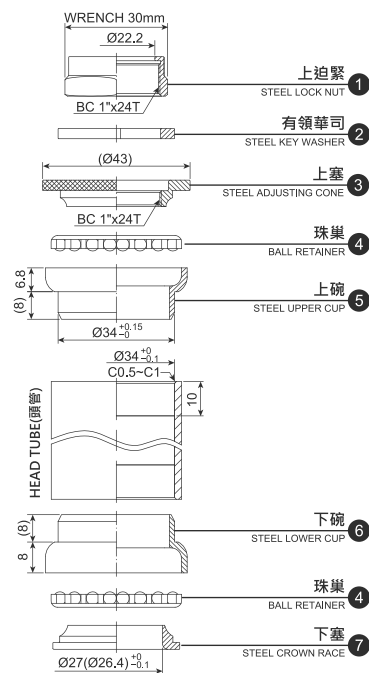

堆積高度 ( STACK HEIGHT ) = 33.5 ± 1 mm

# H834SW



**WEIGHT**

139.4g

**SIZE**

1-1/8"Head Tube  
Reduced to  
1" Fork Tube  
Threaded Headset

**DIMENSIONS**

Ø22.2x34x27(26.4)

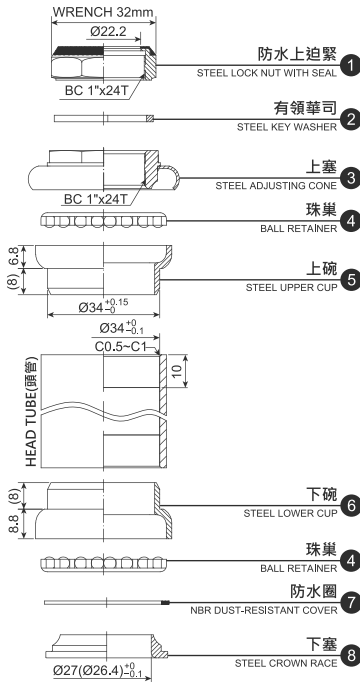

堆積高度 (STACK HEIGHT) = 36 ± 1 mm

# H841G



**WEIGHT**

160.2g

**SIZE**

1-1/8"x26T

**DIMENSIONS**

Ø28.6x34x30

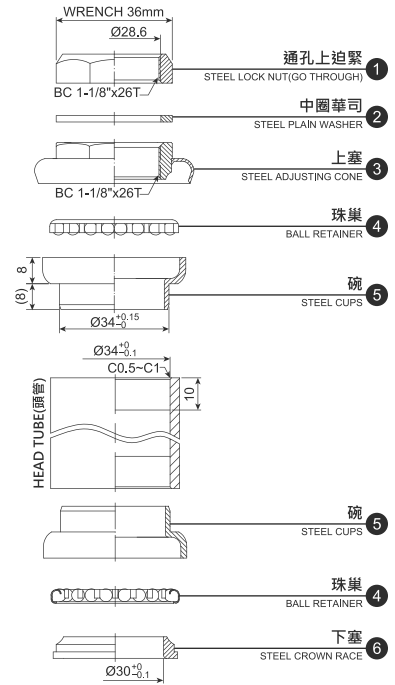

堆積高度 (STACK HEIGHT) = 37.5 ± 1 mm

# H841CW



**WEIGHT**

171.4g

**SIZE**

1-1/8"x26T

**DIMENSIONS**

Ø25.4x34x30

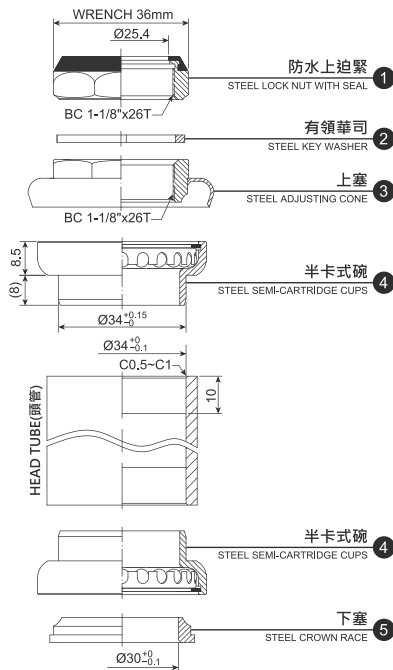

堆積高度 (STACK HEIGHT) = 38 ± 1 mm

# H841SW



**WEIGHT**

161g

**SIZE**

1-1/8"x26T

**DIMENSIONS**

Ø25.4x34x30

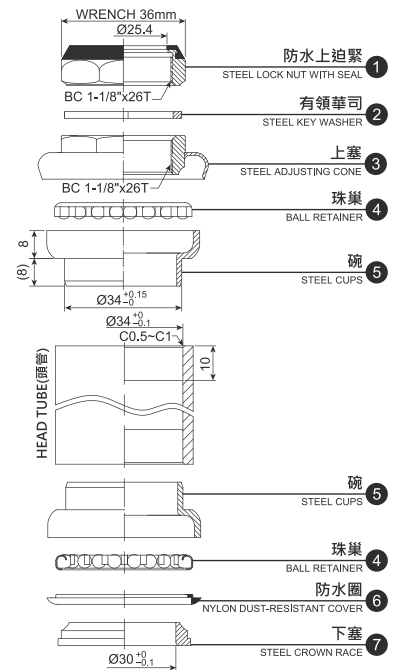

堆積高度 (STACK HEIGHT) = 37.5 ± 1 mm

# NECO EXTERNAL CUP THREADED HEADSETS

外露式有牙車頭碗 EXTERNAL CUP THREADED HEADSETS

## H841SW-P



**WEIGHT**

174g

**SIZE**

1-1/8"x26T

**DIMENSIONS**

Ø25.4x34x30

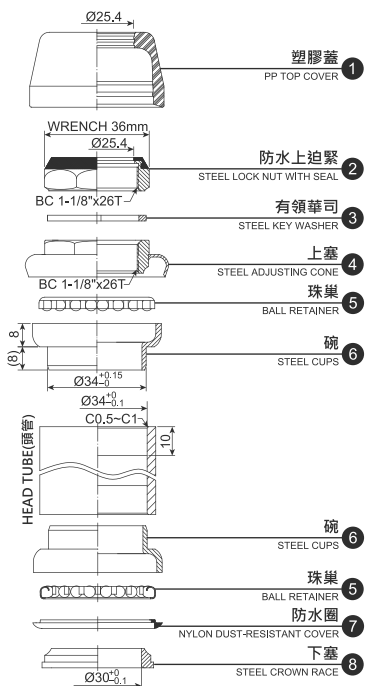

堆積高度 (STACK HEIGHT) = 37.5 ± 1 mm

## H842-2



**WEIGHT**

190g

**SIZE**

1-1/8"x26T

**DIMENSIONS**

Ø25.4x34x30

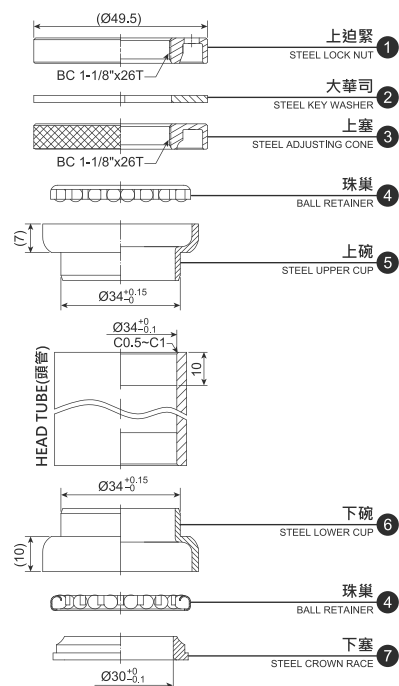

堆積高度 (STACK HEIGHT) = 30.5 ± 1 mm

## H842SW



**WEIGHT**

149g

**SIZE**

1-1/8"x26T

**DIMENSIONS**

Ø25.4x34x30

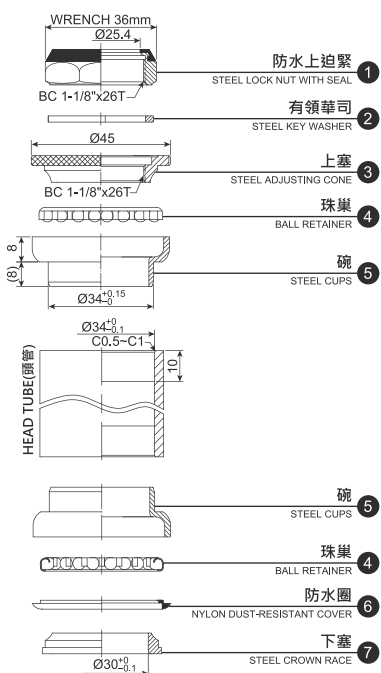

堆積高度 (STACK HEIGHT) = 34 ± 1 mm

## H843NW



**WEIGHT**

188g

**SIZE**

1-1/8"x26T

**DIMENSIONS**

Ø25.4x34x30

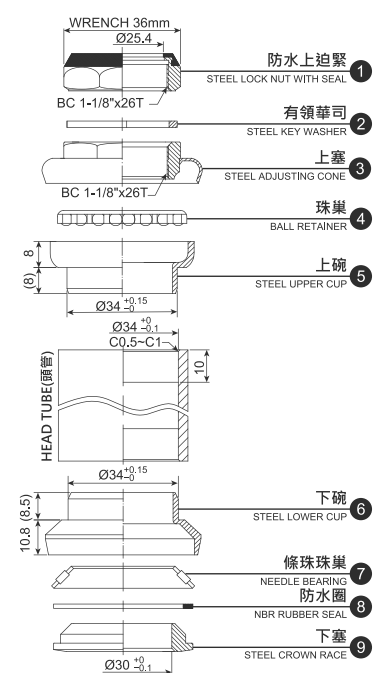

堆積高度 (STACK HEIGHT) = 39 ± 1 mm

# HE8001

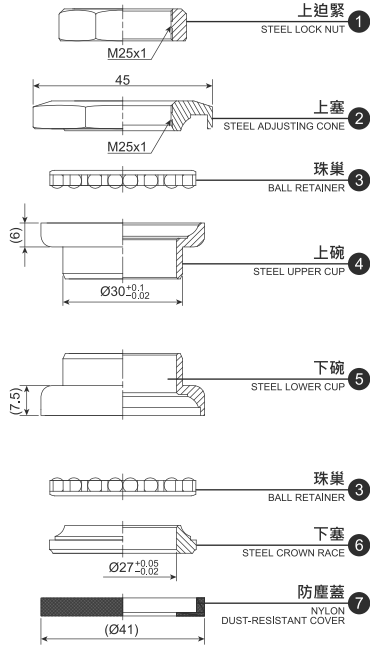
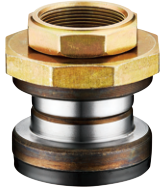

# HE8002

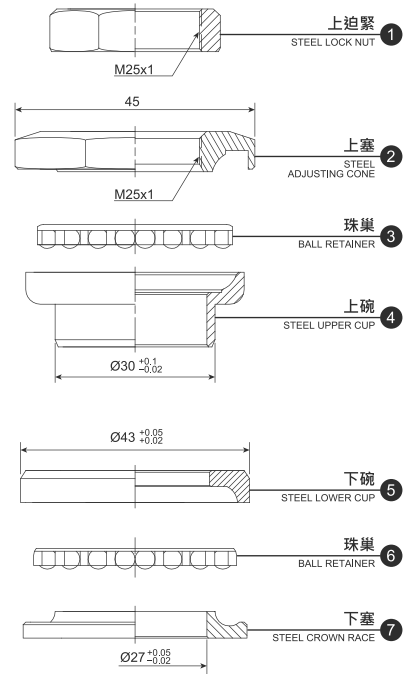
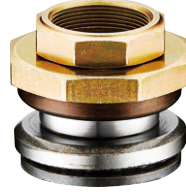

# HE8003

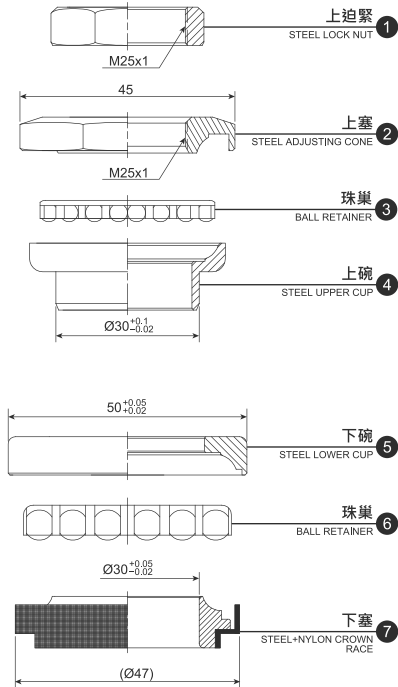
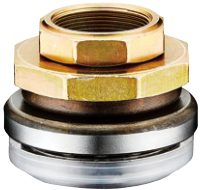

# ACCESSORIES

## 配件



**MECC**



### H361 ALLOY COVER

HEIGHT 高度	31mm
WEIGHT 重量	31g
FINISH 表面處理	Silver,BK
SIZE 尺寸	Aluminum Cover for 1-1/8" Threaded Headset
DIMENSIONS 孔徑	Φ 25.4



### H361H ALLOY COVER

HEIGHT 高度	31mm
WEIGHT 重量	35.5g
FINISH 表面處理	Silver,BK
SIZE 尺寸	Aluminum Cover for 1-1/8" Threaded Headset
DIMENSIONS 孔徑	Φ25.4



### H128 ALLOY COVER

HEIGHT 高度	27.4mm
WEIGHT 重量	19g
FINISH 表面處理	Silver,BK
SIZE 尺寸	Aluminum Cover for 1-1/8" Threaded Headset
DIMENSIONS 孔徑	Φ25.4
OPTIONAL 可選配:	Size:Aluminum Cover for 1"Threaded Headset Dimensions:Φ22.2
H127(1") ALLOY COVER	



### H128H(1-1/8") ALLOY COVER

HEIGHT 高度	27.4mm
WEIGHT 重量	19g
FINISH 表面處理	Silver,BK
SIZE 尺寸	Aluminum Cover for 1-1/8" Threaded Headset
DIMENSIONS 孔徑	Φ25.4 Machined Window for Front Bracket
OPTIONAL 可選配:	Size:Aluminum Cover for 1"Threaded Headset Dimensions:Φ22.2
H127H(1") ALLOY COVER	



### H128 PLASTIC COVER

HEIGHT 高度	26.4mm
WEIGHT 重量	11.2g
FINISH 表面處理	BK
SIZE 尺寸	Plastic Cover for 1-1/8"Threaded Headset
DIMENSIONS 孔徑	Φ25.4
OPTIONAL 可選配:	Size:Plastic Cover for 1"Threaded headset Dimensions:Φ22.2
H831(1") PLASTIC COVER	



### H138P

HEIGHT 高度	27.4mm
WEIGHT 重量	15.8g
FINISH 表面處理	BK
SIZE 尺寸	Plastic Cover For 1.5"Threaded headset
DIMENSIONS 孔徑	Φ25.4



## C286G/C254G

FINISH	表面處理	Silver,Black 銀/黑
SIZE	尺寸	1-1/8"
COMPONENT	內容物	Aluminum Top Cap 鋁頂蓋 Aluminum Body 鋁本體
FORK TUBE ID	立管內徑	Ø22-Ø25.4
DEPTH OF BODY	本體長	18mm C254G Size: 1"
OPTIONAL	可選配	Fork Tube ID 頭管內徑:20-22.2mm
WEIGHT	重量	C286G:42g,C254G:39.4g



## C286GC/C254GC

FINISH	表面處理	Carbon Fiber 碳纖維
SIZE	尺寸	1-1/8"
COMPONENT	內容物	Carbon Top Cap 碳纖維頂蓋 Aluminum Body 鋁本體
FORK TUBE ID	立管內徑	Ø22-Ø25.4
DEPTH OF BODY	本體長	18mm C254GC Size: 1"
OPTIONAL	可選配	Fork Tube ID 立管內徑:20-22.2mm
WEIGHT	重量	C286GC:38.6g,C254GC:35g



## C286GX/C254GX

FINISH	表面處理	Silver,Black 銀/黑
SIZE	尺寸	1-1/8"
COMPONENT	內容物	Aluminum Top Cap 鋁頂蓋 Aluminum Body 鋁本體
FORK TUBE ID	立管內徑	Ø22-Ø25.4
DEPTH OF BODY	本體長	32mm C254GX Size:1"
OPTIONAL	可選配	Fork Tube ID 立管內徑:20-22.2mm
WEIGHT	重量	C286GX:50.9g,C254GX:44.7g



## C286GCX/C254GCX

FINISH	表面處理	Carbon Fiber 碳纖維
SIZE	尺寸	1-1/8"
COMPONENT	內容物	Carbon Top Cap 碳纖維頂蓋 Aluminum Body 鋁本體
FORK TUBE ID	立管內徑	Ø22-Ø25.4
DEPTH OF BODY	本體長	32mm C254GCX Size:1"
OPTIONAL	可選配	Fork Tube ID 立管內徑:20-22.2mm
WEIGHT	重量	C286GCX:47.5g,C254GCX:39.3g



## C286GL

FINISH	表面處理	Silver, Black 銀/黑
SIZE	尺寸	1-1/8"
COMPONENT	內容物	Aluminum Top Cap 鋁頂蓋 Aluminum Body 鋁本體
FORK TUBE ID	立管內徑	Ø22-Ø25.4
DEPTH OF BODY	本體長	52mm
WEIGHT	重量	64.3g



## C286GCL

FINISH	表面處理	Carbon Fiber 碳纖維
SIZE	尺寸	1-1/8"
COMPONENT	內容物	Carbon Top Cap 碳纖維頂蓋 Aluminum Body 鋁本體
FORK TUBE ID	立管內徑	Ø22-Ø25.4
DEPTH OF BODY	本體長	52mm
WEIGHT	重量	61.4g



### C2861/C2541

FINISH 表面處理	Silver, Black 銀/黑
SIZE 尺寸	1-1/8"
COMPONENT 內容物	Aluminum Top Cap 鋁頂蓋 Star Washer 碟片 Steel or Stainless Bolt 鐵或白鐵螺絲 M6xP1.0x30L
OPTIONAL 可選配	C2541 Size: 1"
WEIGHT 重量	C2861:24.6g C2541:23.5g



### C2861DC

FINISH 表面處理	Two Tone Color 雙色
SIZE 尺寸	1-1/8"
COMPONENT 內容物	Aluminum Top Cap 鋁頂蓋 Star Washer 碟片 Steel or Stainless Bolt 鐵或白鐵螺絲 M6xP1.0x30L
WEIGHT 重量	23.7g



### C2861C/C2541C

FINISH 表面處理	Carbon Fiber 碳纖維
SIZE 尺寸	1-1/8"
COMPONENT 內容物	Carbon Top Cap 碳纖維頂蓋 Star Washer 碟片 Stainless Bolt 白鐵螺絲 M6xP1.0x30L
OPTIONAL 可選配	C2541C Size: 1"
WEIGHT 重量	C2861C:21.5g C2541C:20.5g



### C2869/C2549

FINISH 表面處理	Silver, Black 銀/黑
SIZE 尺寸	1-1/8"
COMPONENT 內容物	Aluminum Top Cap 鋁頂蓋 Star Washer 碟片 Steel Hollow Bolt 鐵空心螺絲 M10xP1.25
FORK TUBE 立管外徑內徑	Ø28.6/25.4
OPTIONAL 可選配	C2549 Size: 1"
WEIGHT 重量	C2869:37.9g ; C2549:36.3g



### C2861TT/C2861TS

FINISH 表面處理	Silver, Black 銀/黑
SIZE 尺寸	1-1/8"
COMPONENT 內容物	Aluminum Top Cap 鋁頂蓋 Star Washer 碟片 Stainless Bolt 白鐵螺絲 M6xP1.0x30L
OPTIONAL 可選配	C2861TT:34mm C2861TS:32mm
WEIGHT 重量	C2861TT:29.4g C2861TS:28.9g



### C2862D/C2542D

FINISH 表面處理	Silver, Black 銀/黑
SIZE 尺寸	1-1/8"
COMPONENT 內容物	Aluminum Top Cap 鋁頂蓋 Star Washer 碟片 Steel or Stainless Bolt 鐵或白鐵螺絲 M6xP1.0x30L
OPTIONAL 可選配	C2542D Size: 1"
WEIGHT 重量	C2862D 22.4g C2542D:21.4g



### C371

FINISH 表面處理	Silver, Black 銀/黑
SIZE 尺寸	1-1/8"
COMPONENT 內容物	Aluminum Top Cap 鋁頂蓋 Star Washer 碟片 Steel or Stainless Bolt 鐵或白鐵螺絲 M6xP1.0x30L
FORK TUBE 立管外徑內徑	Ø28.6/Ø25.4
WEIGHT 重量	24g



### C2870

FINISH 表面處理	Silver, Black 銀/黑
SIZE 尺寸	1-1/8"
COMPONENT 內容物	Aluminum Top Cap 鋁頂蓋 Star Washer 碟片 Stainless Bolt 白鐵螺絲 M6xP1.0x30L
FORK TUBE 立管外徑內徑	Ø28.6/Ø25.4
WEIGHT 重量	22.1g



### C371F

FINISH 表面處理	Silver, Black 銀/黑
SIZE 尺寸	1-1/8"
COMPONENT 內容物	Aluminum Top Cap 鋁頂蓋 Star Washer 碟片 Steel or Stainless Bolt 鐵或白鐵螺絲 M6xP1.0x30L
FORK TUBE 立管外徑內徑	Ø28.6/Ø25.4
WEIGHT 重量	27g



## ALLOY SPACER-CC

MATERIAL	材質	Aluminum 鋁
FORK TUBE O.D.	立管外徑	1-1/8"(28.6mm)
SPACER O.D.	墊片外徑	34mm
DEPTH OF BODY	厚度	2.5/5/10/15/20mm



## CARBON SPACER

MATERIAL	材質	Carbon Fiber 碳纖維
FORK TUBE O.D.	立管外徑	1-1/8"(28.6mm)/1"(25.4mm)
SPACER O.D.	墊片外徑	35mm(1-1/8")/31mm(1")
DEPTH OF BODY	厚度	3/5/8/10/15/20mm



## ALLOY SPACER

MATERIAL	材質	Aluminum 鋁
FORK TUBE O.D.	立管外徑	1-1/8"(28.6mm)/1"(25.4mm)
SPACER O.D.	墊片外徑	36mm(1-1/8")/32mm(1")
DEPTH OF BODY	厚度	2/5/8/10/15/20mm



## C204

### INNER & OUTER EXPANDER

FINISH	表面處理	Silver,Black 銀/黑
SIZE	尺寸	1-1/8"
		Aluminum Top Cap 鋁頂蓋
		Expander Bolt 加長型螺絲
COMPONENT	內容物	M6xP1.0x200L



## C203

### INNER & OUTER EXPANDER

FINISH	表面處理	Silver,Black 銀/黑
SIZE	尺寸	1-1/8"
		Aluminum Top Cap 鋁頂蓋
		Expander Bolt 加長型螺絲
COMPONENT	內容物	M6xP1.0x200L



## ALLOY SPACER-R

### ALLOY SPACERS WITH RADIUS OUTER LOOK

MATERIAL	材質	Aluminum 鋁
FORK TUBE O.D.	立管外徑	1-1/8"(28.6mm)/1"(25.4mm)
SPACER O.D.	墊片外徑	36mm(1-1/8")/32mm(1")
DEPTH OF BODY	厚度	5/10/15/20mm

## 286G 系列組拆裝說明

### Assembly of Tension Adjust

Assembling description, please see the illustration as below:

1. Put the fixer of Tension Adjust (T.A.) on the steer. see fig. 1.
2. Use the allen key(6mm) to screw in allen bolt tight to be very firmly. (recommended torque about 7~10N.m;72~102kgf-cm) see fig. 2.
3. Put the stem on the steer. see fig. 3.
4. Put the alloy cap of T.A. on the stem. see fig. 4.
5. Use the allen key to screw in the bolt of alloy cap tight. (recommended torque about 5~8N.m;51~82kgf-cm) see fig. 5.
6. Use the allen key to screw in the bolts of stem tight to be very firmly, see fig. 6. (if enclosed with rubber cover, place the rubber cap in the allen bolt.)

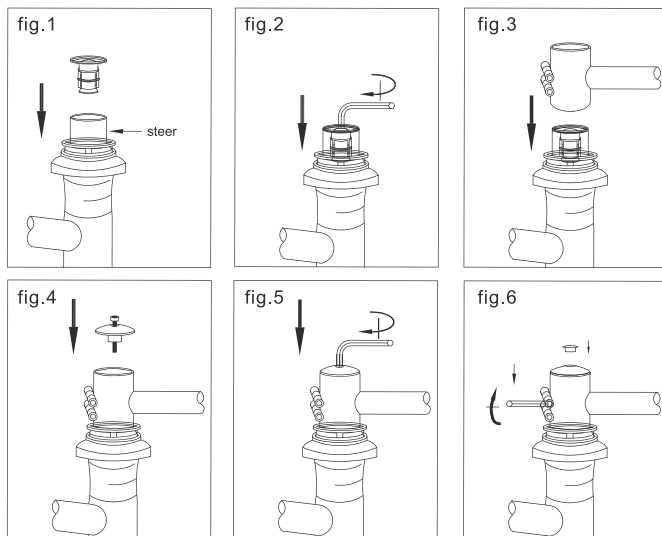

### Disassembly of Tension Adjust

Disassembling description, please see the illustration as below:

1. (If enclosed with rubber cover, remove the rubber cap from the allen bolt.) Use the allen key to unscrew the bolt of alloy cap. see fig. 1, and take it out. see fig. 2.
2. Use the allen key to unscrew the bolts of stem. see fig. 3, and take it out. see fig.4.
3. Use the allen key(6mm) to unscrew the fixer of T.A. until it is about 3mm above the steer. see fig. 5. Then use your palm to hit lightly until it come off the steer, and take it out. see fig. 6.

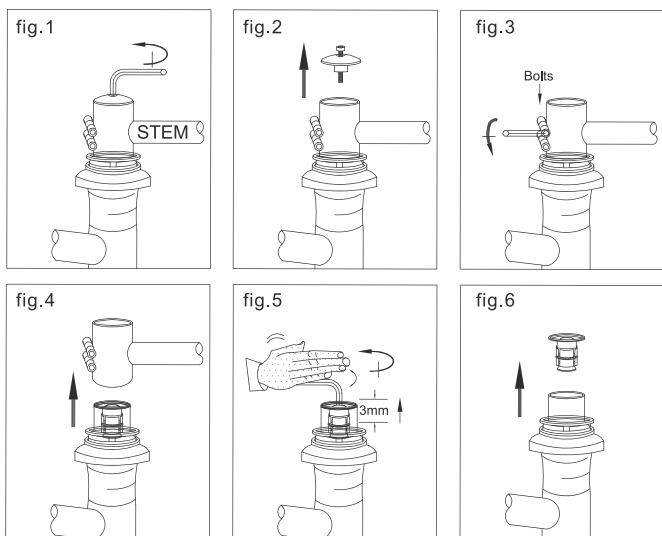

**Warning:** Always ensure all bolts are secured tightly before riding, if you are unclear about the installation and adjustment of this product, your headset or stem, see your professional bicycle dealer for advice. If you have questions about threadless headset assembling instruction please contact your local dealers.

### 上迫緊器組裝方法

請見以下組裝說明：

1. 將下迫緊件放入前叉豎管內,如fig.1.
2. 使用內六角板手(6mm)將下迫緊件鎖緊至適當鬆緊度。(建議扭力約7~10N.m;72~102kgf-cm)如fig.2.
3. 放入車手立管,如fig.3.
4. 放入上迫緊件(鋁蓋+螺絲),如fig.4.
5. 使用內六角板手將上迫緊件鎖緊至適當鬆緊度(建議扭力約5~8N.m;51~82kgf-cm)如fig.5.
6. 使用內六角板手將車手立管上螺絲 緊至適當鬆緊度,如fig.6.(若有附上橡膠上蓋,則將橡膠上蓋壓入螺絲六角孔內.)

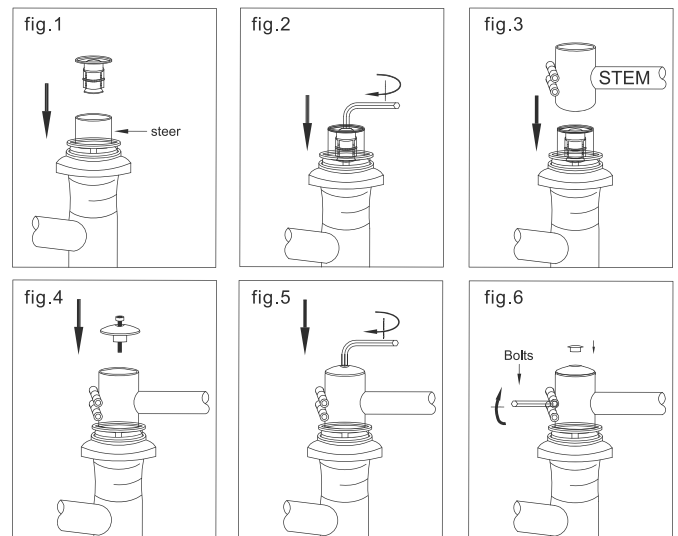

### 上迫緊器拆卸方法

請見以下拆卸說明：

1. (若有附上橡膠上蓋,則將橡膠上蓋自螺絲六角孔內取出.) 使用內六角板手將上迫緊件上的螺絲放鬆,如fig.1,然後將上迫緊件取出如fig.2.
2. 使用內六角板手將車手立管上螺絲放鬆.如fig.3,然後將立管取出.如fig.4. (如果前叉不換時,可不執行第三步驟)
3. 使用內六角板手(6mm)將下迫緊件放鬆,直到下迫緊器上移為3mm (相對於前叉立管的高度),如fig.5.然後用手掌拍打下緊迫件,直到整個下緊迫件不再緊貼前叉豎管,然後取出.如fig.6.

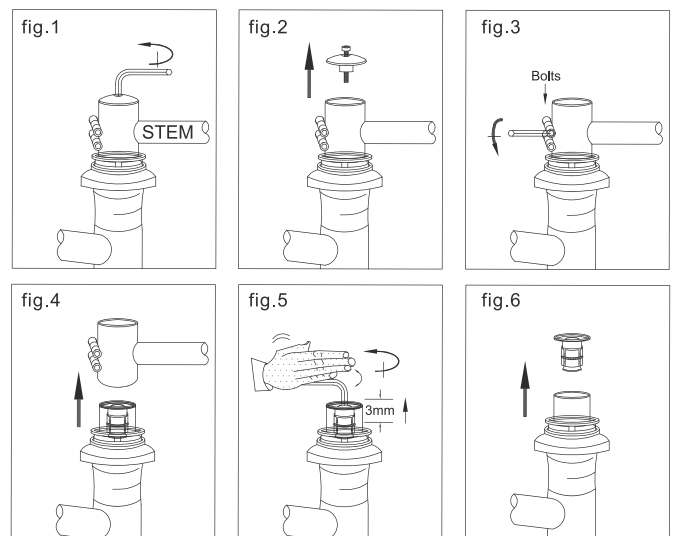

**注意事項:** 騎行前請注意所有螺絲件是否有鎖緊.若你不是很了解產品的組裝或調整方式包括你的車頭碗組及車手立管,請洽專業的自行車店給予協助.對於組裝說明有任何疑問或問題,請洽詢專業的自行車店提供協助.

# BOTTOM BRACKET B.B. 五通碗組



**NECO**

外牙中軸  
**Nut Type Cotterless Axle**

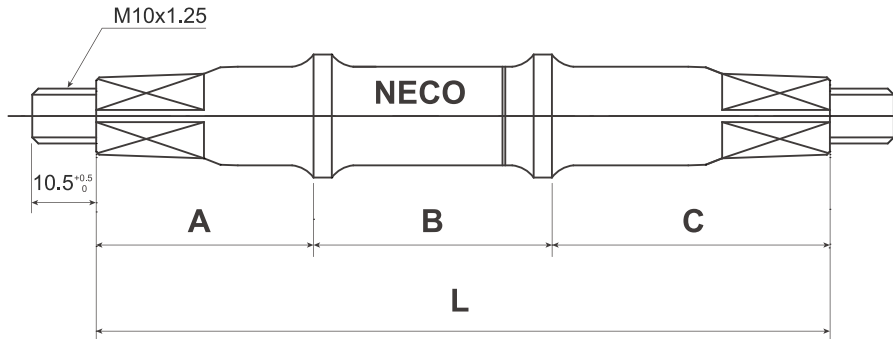

內牙中軸  
**Bolt Type Cotterless Axle**

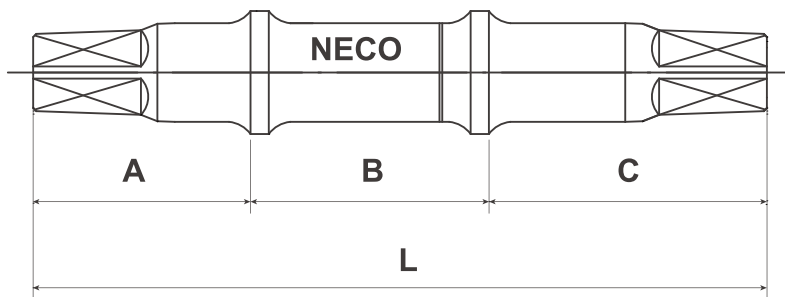

內外牙中軸尺寸圖  
**Bolt/Nut Type Axle Dimension Chart**

AXLE MODEL	3H	3E	3M	3J	3L	3A	3P	3PL	3N	3NL	3SS	3S	3T	3U	3UM	3R	3RM	3RMC	3MC
BRACKET WIDTH	68	68	68	68	68	68	68	68	68	68	68	68	68	68	68	68	68	68	68
A	28	28	29	30.5	32	32	32	35	32	35	32	35	35	35	37.5	35	37.5	40.5	32
B	52	52	52	52	52	52	52	52	52	52	52	52	52	52	52	52	52	52	52
C	28	30.5	29	30.5	32	33.5	35	35	36	36	37.5	37.5	39	40.5	40.5	42	42	42	43.5
L	108.0	110.5	110	113	116	117.5	119	122	120	123.0	121.5	124.5	126	127.5	130	129	131.5	134.5	127.5

AXLE MODEL	5A	5P	5SS	5S	5T	5U	5R	7J	7L	7A	7P	7PL	7N	7NN	7SS	7S	7T	7U	7R
BRACKET WIDTH	70	70	70	70	70	70	70	73	73	73	73	73	73	73	73	73	73	73	73
A	32	32	32	35	35	35	35	30.5	32	32	32	35	32	36	32	35	35	35	35
B	54	54	54	54	54	54	54	57	57	57	57	57	57	57	57	57	57	57	57
C	33.5	35	37.5	37.5	39	40.5	42	30.5	32	33.5	35	35	36	36	37.5	37.5	39	40.5	42
L	119.5	121.0	123.5	126.5	128	129.5	131	118	121	122.5	124	127	125	129	126.5	129.5	131	132.5	134

PS:橘字尺寸有最低訂購量限制。Orange Number Dimension,have MOQ limit.

## B906 / (B906E) / (B906B)

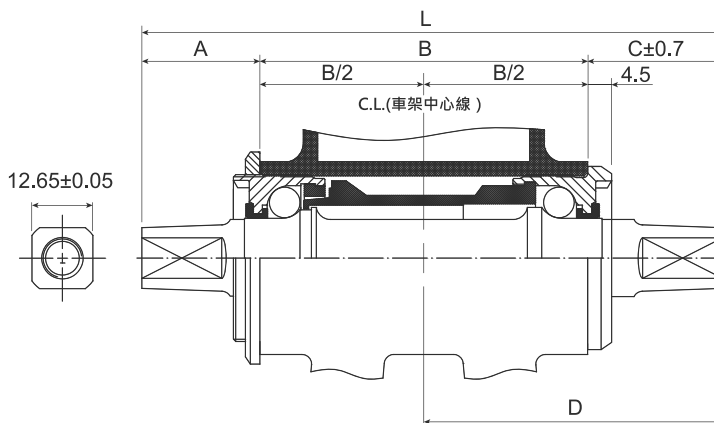

COMPONENTS	內容物	10B21 Spindle, Dust Seal & Pre-Lubed Cartridge Steel Cups, Plastic Body 鐵軸心, 防塵蓋, 卡式鐵牙碗, 塑膠中管
LOCKING RING COLOR	鎖環顏色	Black 黑
CUP COLOR	碗顏色	Black 黑
APPLICATIONS	適合車種	MTB 登山車, Road 公路車
WEIGHT(LENGTH122.5)	重量(長度122.5)	B906/315g
Threads	牙紋規格	BC 1.37"x24T R/L(B906/B906E) BC 36mmx24T R/R(B906B)
Steel cups	鐵左右碗	B906/B906B
E-type steel cup	鐵左右碗,右碗為 E-type	E-type(B906E)

AXLE MODEL 中軸代號	AXLE LENGTH 中軸長度	B.B. SHELL WIDTH=68mm 五通管寬度 68mm				B.B. SHELL WIDTH=70mm 五通管寬度 70mm			
		L	A	B	C	D	A	B	C
2H	108.0(29.0/50/29.0)	20.5	68	19.5	53.5	18.5	70	19.5	54.5
2M	111.0(30.5/50/30.5)	22.0	68	21.0	55.0	20.0	70	21.0	56.0
2J	113.5(31.5/50/32.0)	23.0	68	22.5	56.5	21.0	70	22.5	57.5
2L	116.0(33.0/50/33.0)	24.5	68	23.5	57.5	22.5	70	23.5	58.5
2A	118.0(33.0/50/35.0)	24.5	68	25.5	59.5	22.5	70	25.5	60.5
2P	119.0(33.0/50/36.0)	24.5	68	26.5	60.5	22.5	70	26.5	61.5
2N	120.5(33.0/50/37.5)	24.5	68	28.0	62.0	22.5	70	28.0	63.0
2SS	122.0(33.0/50/39.0)	24.5	68	29.5	63.5	22.5	70	29.5	64.5
2NL	122.5(35.0/50/37.5)	26.5	68	28.0	62.0	24.5	70	28.0	63.0
2S	125.0(36.0/50/39.0)	27.5	68	29.5	63.5	25.5	70	29.5	64.5
2T	126.5(36.0/50/40.5)	27.5	68	31.0	65.0	25.5	70	31.0	66.0
2U	128.0(36.0/50/42.0)	27.5	68	32.5	66.5	25.5	70	32.5	67.5
2R	129.5(36.0/50/43.5)	27.5	68	34.0	68.0	25.5	70	34.0	69.0
2UM	131.0(39.0/50/42.0)	30.5	68	32.5	66.5	28.5	70	32.5	67.5
2RMC	135.5(42.0/50/43.5)	33.5	68	34.0	68.0	31.5	70	34.0	69.0

PS:橘字尺寸有最低訂購量限制。Orange Number Dimension,have MOQ limit.

# B910/(B910E)/(B910P)/(B910B)/ (B910PP)/(B910T)/(B910TE)/(B910PPT)

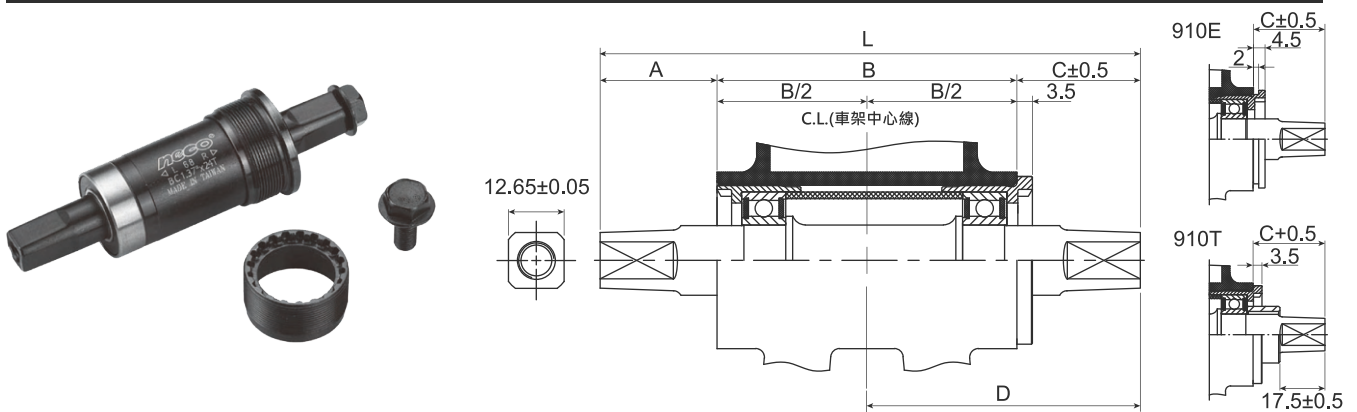

COMPONENTS	內容物	10B21 Spindle & Steel cups, Steel Body, Sealed Bearing 2pcs 鐵軸心, 鐵牙碗, 鐵中管, 培林x2
CUP COLOR	碗顏色	Black 黑
APPLICATIONS	適合車種	MTB 登山車, Road 公路車
WEIGHT(LENGTH122.5)	重量(長度122.5)	B910/312.6g, B910P/292g, B910PP/266g

Threads	牙紋規格	BC 1.37"x24T R/L(B910/B910E/B910P/B910PP) BC 36mmx24T R/R(B910B)
Steel cups	鐵左右碗	B910/B910B
Steel right cup & nylon left cup	鐵右碗, 塑鋼左碗	B910P
Nylon cups	塑鋼左右碗	B910PP
E-type steel cup	鐵左右碗, 右碗為 E-type	B910E
Alloy tube	鋁檔管	B910T

LENGTH 中軸長度	B.B. SHELL WIDTH=68mm 五通管寬度 68mm				B.B. SHELL WIDTH=70mm 五通管寬度 70mm				B.B. SHELL WIDTH=73mm 五通管寬度 73mm				
	L	A	B	C	D	A	B	C	D	A	B	C	D
103.0	(16.5)	68	18.5	52.5									
107.5	(19.0)	68	20.5	54.5									
110.5	(22.0)	68	20.5	54.5	(21.0)	70	19.5	54.5					
113.5	(22.5)	68	23.0	57.0	(21.5)	70	22.0	57.0	(20.0)	73	20.5	57.0	
115.0	(23.0)	68	24.0	58.0	(22.0)	70	23.0	58.0	(20.5)	73	21.5	58.0	
116.0	(23.0)	68	25.0	59.0	(22.0)	70	24.0	59.0	(20.5)	73	22.5	59.0	
118.0	(25.0)	68	25.0	59.0	(24.0)	70	24.0	59.0	(22.5)	73	22.5	59.0	
119.0	(24.0)	68	27.0	61.0	(23.0)	70	26.0	61.0	(21.5)	73	24.5	61.0	
122.5	(26.0)	68	28.5	62.5	(25.0)	70	27.5	62.5	(23.5)	73	26.0	62.5	
124.5	(27.0)	68	29.5	63.5	(26.0)	70	28.5	63.5	(24.5)	73	27.0	63.5	
126.0	(27.0)	68	31.0	65.0	(26.0)	70	30.0	65.0	(24.5)	73	28.5	65.0	
127.5	(28.5)	68	31.0	65.0	(27.5)	70	30.0	65.0	(26.0)	73	28.5	65.0	
131.0	(29.0)	68	34.0	68.0	(28.0)	70	33.0	68.0	(26.5)	73	31.5	68.0	
134.0	(30.0)	68	36.0	70.0	(29.0)	70	35.0	70.0	(27.5)	73	33.5	70.0	
147.0	(36.0)	68	41.0	75.0									

PS:橘字尺寸有最低訂購量限制。Orange Number Dimension, have MOQ limit.

# B910NT

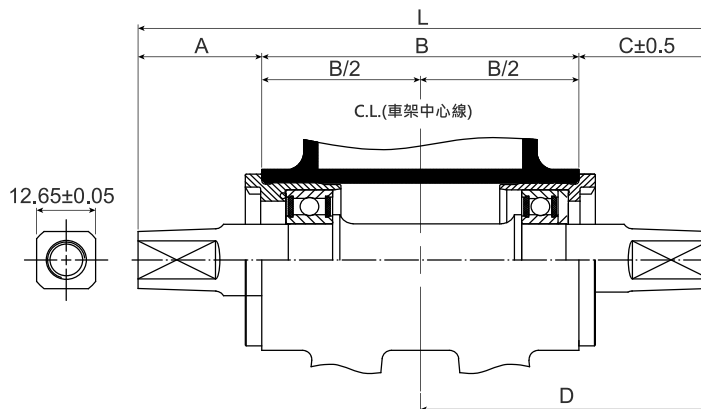

COMPONENTS	內容物	10B21 Spindle & Nylon cups Sealed Bearing 2pcs 鐵軸心 塑鋼牙碗, 培林x2
CUP COLOR	碗顏色	Black 黑
APPLICATIONS	適合車種	MTB登山車, Road公路車
Threads	牙紋規格	BC 1.37"x24T R/L

LENGTH 中軸長度	B.B. SHELL WIDTH=68mm 五通管寬度 68mm				B.B. SHELL WIDTH=70mm 五通管寬度 70mm				B.B. SHELL WIDTH=73mm 五通管寬度 73mm				
	L	A	B	C	D	A	B	C	D	A	B	C	D
107.5	(19.0)	68	20.5	54.5									
110.5	(22.0)	68	20.5	54.5	(21.0)	70	19.5	54.5					
113.5	(22.5)	68	23.0	57.0	(21.5)	70	22.0	57.0	(20.0)	73	20.5	57.0	
115.0	(23.0)	68	24.0	58.0	(22.0)	70	23.0	58.0	(20.5)	73	21.5	58.0	
116.0	(23.0)	68	25.0	59.0	(22.0)	70	24.0	59.0	(20.5)	73	22.5	59.0	
118.0	(25.0)	68	25.0	59.0	(24.0)	70	24.0	59.0	(22.5)	73	22.5	59.0	
119.0	(24.0)	68	27.0	61.0	(23.0)	70	26.0	61.0	(21.5)	73	24.5	61.0	
122.5	(26.0)	68	28.5	62.5	(25.0)	70	27.5	62.5	(23.5)	73	26.0	62.5	
124.5	(27.0)	68	29.5	63.5	(26.0)	70	28.5	63.5	(24.5)	73	27.0	63.5	
126.0	(27.0)	68	31.0	65.0	(26.0)	70	30.0	65.0	(24.5)	73	28.5	65.0	
127.5	(28.5)	68	31.0	65.0	(27.5)	70	30.0	65.0	(26.0)	73	28.5	65.0	
131.0	(29.0)	68	34.0	68.0	(28.0)	70	33.0	68.0	(26.5)	73	31.5	68.0	
134.0	(30.0)	68	36.0	70.0	(29.0)	70	35.0	70.0	(27.5)	73	33.5	70.0	
147.0	(36.0)	68	41.0	75.0									

PS:橘字尺寸有最低訂購量限制。Orange Number Dimension, have MOQ limit.

# B911 / (B911E)

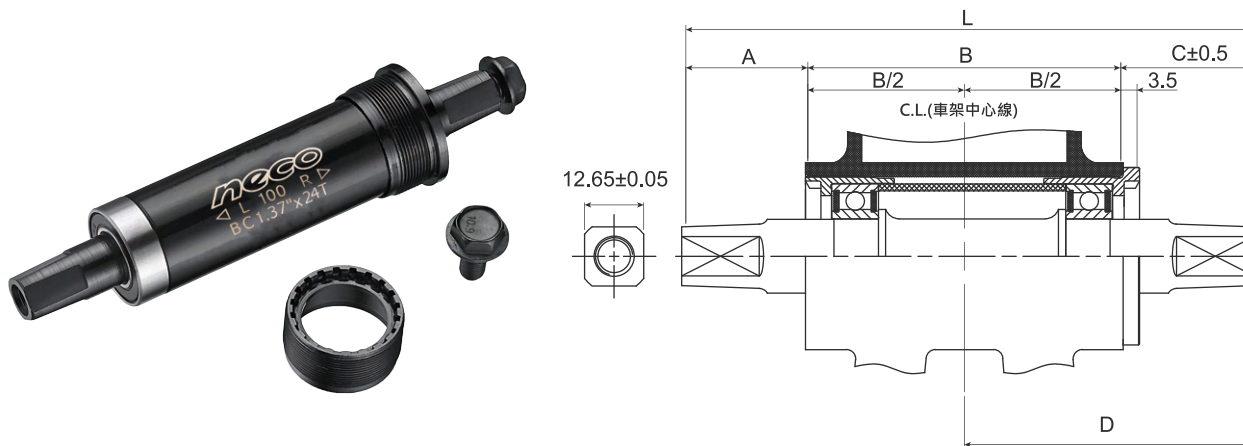

COMPONENTS	內容物	10B21 Spindle & Steel cups, Steel Body, Sealed Bearing 2pcs 鐵軸心, 鐵牙碗, 鐵中管, 培林x2
CUP COLOR	碗顏色	Black 黑
APPLICATIONS	適合車種	Fat Bike 雪地車
WEIGHT(LENGTH179.5)	重量(長度179.5)	B911/458g

Threads	牙紋規格	BC 1.37"x24T R/L
E-type steel cup	鐵左右碗,右碗為 E-type	B911E

LENGTH 中軸長度	B.B. SHELL WIDTH=100mm 五通管寬度 100mm				B.B. SHELL WIDTH=120mm 五通管寬度 120mm				
	L	A	B	C	D	A	B	C	D
151.0	27.8	100	23.2	73.2					
159.5	30.8	100	28.7	78.7					
164.0	29.5	100	34.5	84.5					
<b>177.0</b>	<b>38</b>	<b>100</b>	<b>39</b>	<b>89</b>					
167.0					28.5	120	18.5	78.5	
167.0					25.0	120	22.0	82.0	
167.0					22.0	120	25.0	85.0	
179.5					30.8	120	28.7	88.7	

# B920 / (B920E) / (B908) / (B920AAL) / (B920BAL)

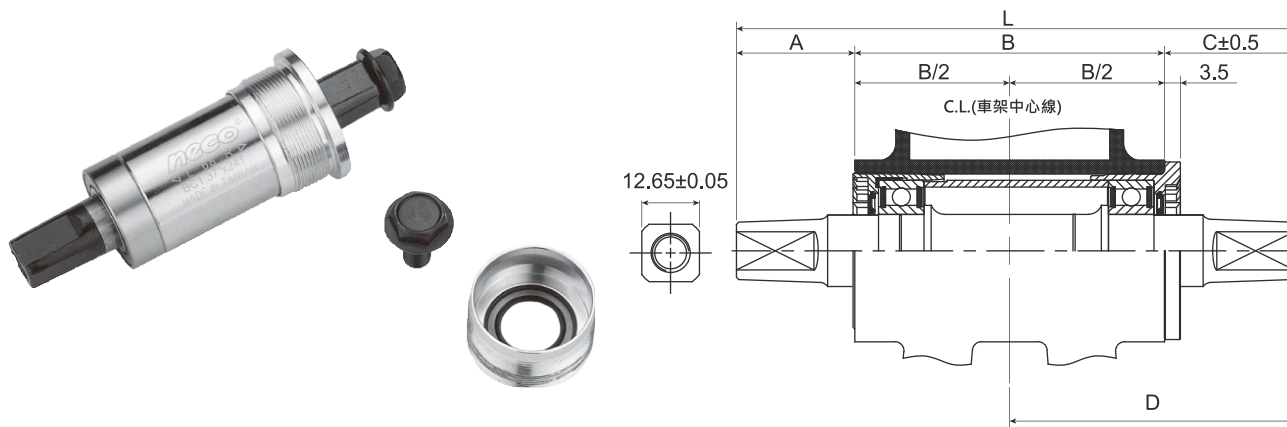

COMPONENTS	內容物	10B21 Axle & Alloy cups, Steel Body, Sealed Bearing 2pcs 鐵軸心, 鋁牙碗, 鐵中管, 培林x2
APPLICATIONS	適合車種	MTB 登山車, Road 公路車
WEIGHT(LENGTH122.5)	重量(長度122.5)	B908/310.4g, B920AL/277g, B920AAL/250g
Threads	牙紋規格	BC 1.37"x24T R/L(B920/B920E/B908/B920AAL) BC 36mmx24T R/R(B920BAL)
Alloy cups, Steel Body	鋁碗, 鐵中管	B920
Steel cups, Alloy Body	鐵碗, 鋁中管	B908
Alloy cups, Alloy Body	鋁碗, 鋁中管	B920AAL
E-type alloy cup	鋁碗, 鐵中管, 右碗為 E-type	B920E

LENGTH 中軸長度	B.B. SHELL WIDTH=68mm 五通管寬度 68mm				B.B. SHELL WIDTH=70mm 五通管寬度 70mm				B.B. SHELL WIDTH=73mm 五通管寬度 73mm				
	L	A	B	C	D	A	B	C	D	A	B	C	D
103.0	(16.5)	68	18.5	52.5									
107.5	(19.0)	68	20.5	54.5									
110.5	(22.0)	68	20.5	54.5	(21.0)	70	19.5	54.5					
113.5	(22.5)	68	23.0	57.0	(21.5)	70	22.0	57.0	(20.0)	73	20.5	57.0	
115.0	(23.0)	68	24.0	58.0	(22.0)	70	23.0	58.0	(20.5)	73	21.5	58.0	
116.0	(23.0)	68	25.0	59.0	(22.0)	70	24.0	59.0	(20.5)	73	22.5	59.0	
118.0	(25.0)	68	25.0	59.0	(24.0)	70	24.0	59.0	(22.5)	73	22.5	59.0	
119.0	(24.0)	68	27.0	61.0	(23.0)	70	26.0	61.0	(21.5)	73	24.5	61.0	
122.5	(26.0)	68	28.5	62.5	(25.0)	70	27.5	62.5	(23.5)	73	26.0	62.5	
124.5	(27.0)	68	29.5	63.5	(26.0)	70	28.5	63.5	(24.5)	73	27.0	63.5	
126.0	(27.0)	68	31.0	65.0	(26.0)	70	30.0	65.0	(24.5)	73	28.5	65.0	
127.5	(28.5)	68	31.0	65.0	(27.5)	70	30.0	65.0	(26.0)	73	28.5	65.0	
131.0	(29.0)	68	34.0	68.0	(28.0)	70	33.0	68.0	(26.5)	73	31.5	68.0	

# B920HAL / (B920HBAL)

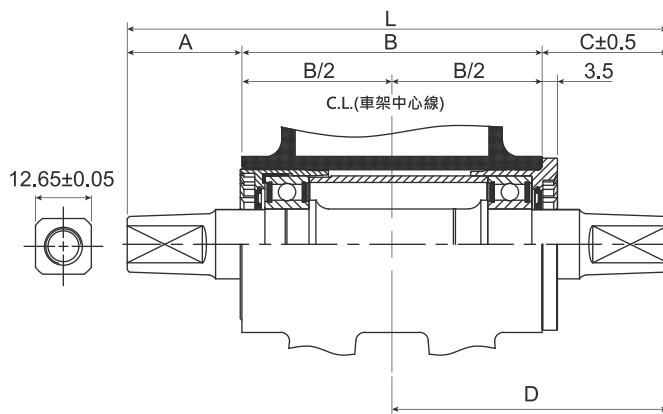

COMPONENTS	內容物	Cr-mo Stain Hollow Spindle & Alloy cups, Steel Body, Sealed Bearing 2pcs 鉻鉬鋼中空軸心, 鋁牙碗, 鐵中管, 培林x2
APPLICATIONS	適合車種	Trekking Bike 旅行車, Comfort Bike 城市車
WEIGHT(LENGTH122.5)	重量(長度122.5)	B920HAL/255g
Threads	牙紋規格	BC 1.37"x24T R/L(B920HAL) BC 36mmx24T R/R(B920HBAL)

LENGTH 中軸長度	B.B. SHELL WIDTH=68mm 五通管寬度 68mm				B.B. SHELL WIDTH=70mm 五通管寬度 70mm				B.B. SHELL WIDTH=73mm 五通管寬度 73mm				
	L	A	B	C	D	A	B	C	D	A	B	C	D
107.5	(19.0)	68	20.5	54.5									
110.5	(22.0)	68	20.5	54.5	(21.0)	70	19.5	54.5					
113.5	(22.5)	68	23.0	57.0	(21.5)	70	22.0	57.0	(20.0)	73	20.5	57.0	
115.0	(23.0)	68	24.0	58.0	(22.0)	70	23.0	58.0	(20.5)	73	21.5	58.0	
116.0	(23.0)	68	25.0	59.0	(22.0)	70	24.0	59.0	(20.5)	73	22.5	59.0	
118.0	(25.0)	68	25.0	59.0	(24.0)	70	24.0	59.0	(22.5)	73	22.5	59.0	
119.0	(24.0)	68	27.0	61.0	(23.0)	70	26.0	61.0	(21.5)	73	24.5	61.0	
122.5	(26.0)	68	28.5	62.5	(25.0)	70	27.5	62.5	(23.5)	73	26.0	62.5	
127.5	(28.5)	68	31.0	65.0	(27.5)	70	30.0	65.0	(26.0)	73	28.5	65.0	
131.0	(29.0)	68	34.0	68.0	(28.0)	70	33.0	68.5	(26.5)	73	31.5	68.5	

# B940 / (B940E)

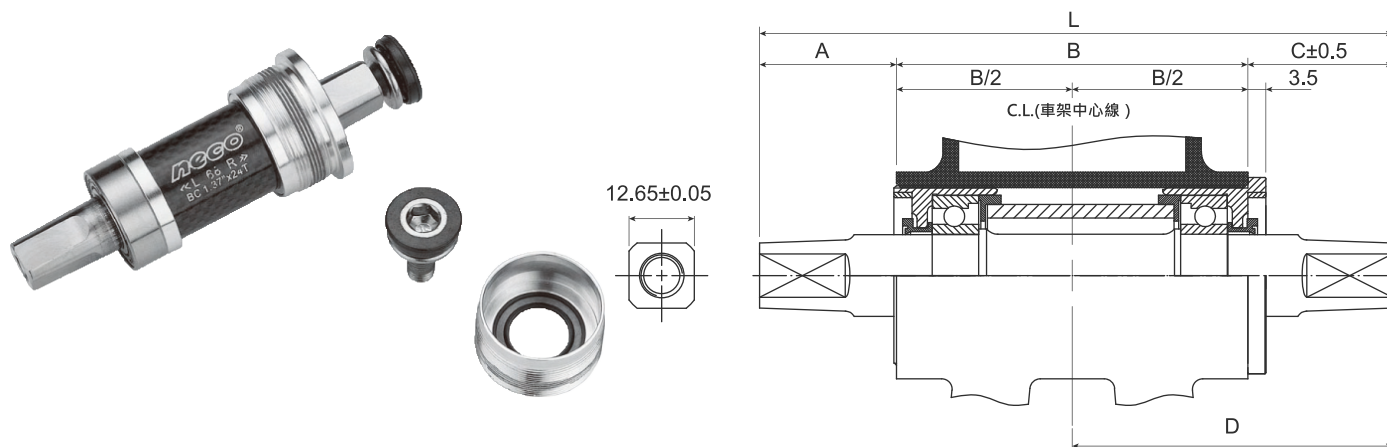

COMPONENTS	內容物	Cr-Mo Stain Hollow Spindle, Carbon Body & Alloy cups, Sealed Bearing 2pcs 鉻鉬鋼空心軸心, 碳纖維中管, 鋁碗, 培林x2
APPLICATIONS	適合車種	MTB 登山車, Road 公路車
WEIGHT(LENGTH122.5)	重量(長度122.5)	228g
Threads	牙紋規格	BC 1.37"x24T R/L
E-type alloy cup	右碗為 E-type	B940E

LENGTH 中軸長度	B.B. SHELL WIDTH=68mm 五通管寬度 68mm				B.B. SHELL WIDTH=70mm 五通管寬度 70mm				B.B. SHELL WIDTH=73mm 五通管寬度 73mm				
	L	A	B	C	D	A	B	C	D	A	B	C	D
107.5	(19.0)	68	20.5	54.5									
110.5	(22.0)	68	20.5	54.5	(21.0)	70	19.5	54.5					
113.5	(22.5)	68	23.0	57.0	(21.5)	70	22.0	57.0	(20.0)	73	20.5	57.0	
115.0	(23.0)	68	24.0	58.0	(22.0)	70	23.0	58.0	(20.5)	73	21.5	58.0	
116.0	(23.0)	68	25.0	59.0	(22.0)	70	24.0	59.0	(20.5)	73	22.5	59.0	
118.0	(25.0)	68	25.0	59.0	(24.0)	70	24.0	59.0	(22.5)	73	22.5	59.0	
122.5	(26.0)	68	28.5	62.5	(25.0)	70	27.5	62.5	(23.5)	73	26.0	62.5	
127.5	(28.5)	68	31.0	65.0	(27.5)	70	30.0	65.0	(26.0)	73	28.5	65.0	

# B940CT

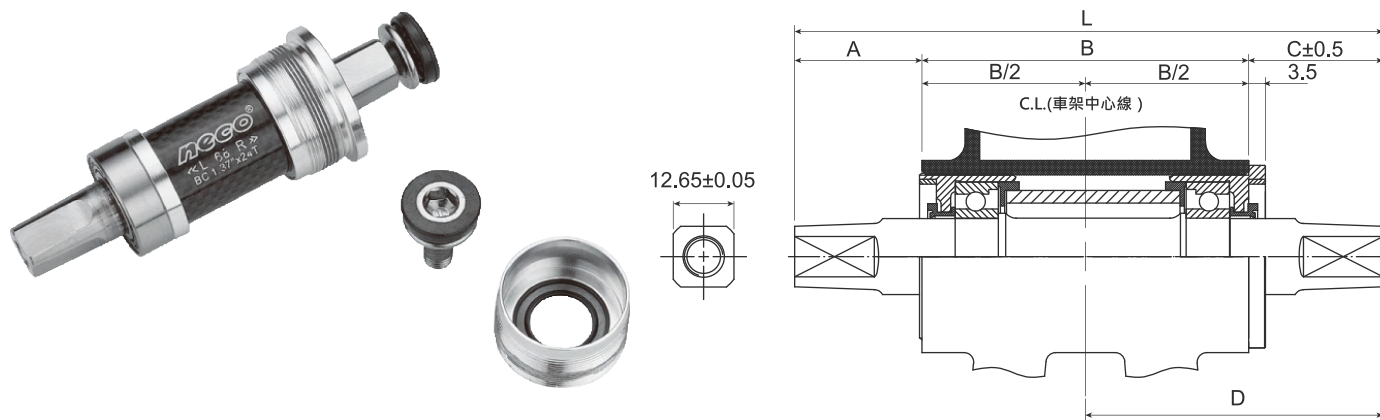

COMPONENTS	內容物	Titanium Hollow Axle, Carbon Body & Alloy cups, Sealed Bearing 2pcs 鈦空心軸心, 碳纖維中管, 鋁碗, 培林x2
APPLICATIONS	適合車種	MTB 登山車, Road 公路車
WEIGHT(LENGTH122.5)	重量(長度122.5)	158g
Threads	牙紋規格	BC 1.37"x24T R/L

LENGTH 中軸長度	B.B. SHELL WIDTH=68mm 五通管寬度 68mm				B.B. SHELL WIDTH=70mm 五通管寬度 70mm				B.B. SHELL WIDTH=73mm 五通管寬度 73mm				
	L	A	B	C	D	A	B	C	D	A	B	C	D
103.0	(16.5)	68	18.5	52.5									
107.5	(19.0)	68	20.5	54.5									
110.5	(22.0)	68	20.5	54.5	(21.0)	70	19.5	54.5					
113.5	(22.5)	68	23.0	57.0	(21.5)	70	22.0	57.0	(20.0)	73	20.5	57.0	
115.0	(23.0)	68	24.0	58.0	(22.0)	70	23.0	58.0	(20.5)	73	21.5	58.0	
116.0	(23.0)	68	25.0	59.0	(22.0)	70	24.0	59.0	(20.5)	73	22.5	59.0	
118.0	(25.0)	68	25.0	59.0	(24.0)	70	24.0	59.0	(22.5)	73	22.5	59.0	
122.5	(26.0)	68	28.5	62.5	(25.0)	70	27.5	62.5	(23.5)	73	26.0	62.5	
127.5	(28.5)	68	31.0	65.0	(27.5)	70	30.0	65.0	(26.0)	73	28.5	65.0	

## B952

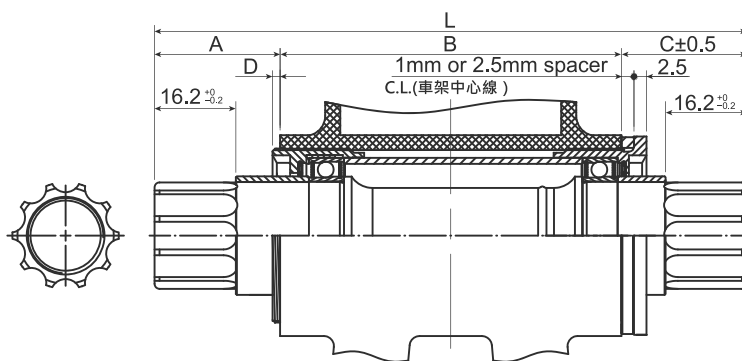

COMPONENTS	內容物	ISIS Spline Hollow Axle(SCM440), Cold Forged & CNC Machined Steel Cups, Steel Body, Sealed Bearing 2pcs 鉻鉬鋼中空軸心, 鐵碗, 鐵中管, 培林x2
WEIGHT(LENGTH118)	重量(長度118)	280g
Threads	牙紋規格	BC 1.37"x24T R/L
B.B Shell Width	五通管寬度	68mm,73mm

LENGTH 中軸長度	B.B. SHELL WIDTH=68mm 五通管寬度 68mm				B.B. SHELL WIDTH=73mm 五通管寬度 73mm			BOLT THREAD 螺絲尺寸
	L	A	B	C	D	A	B	
108.0	20.0	68	20.0 (w/o SPACER)	0	Not Compatible (不相容)			M15xP1
113.0	22.5	68	22.5 (w/2.5mm spacer)	1.5	20.0	73	20.0	M15xP1
118.0	25.0	68	25.0(w/2.5mm spacer)	1.5	22.5	73	22.5	M15xP1
128.0	30.0	68	30.0(w/2.5mm spacer)	1.5	27.5	73	27.5	M12xP1
135.0	33.5	68	33.5(w/2.5mm spacer)	1.5	31.0	73	31.0	M12xP1

# B953

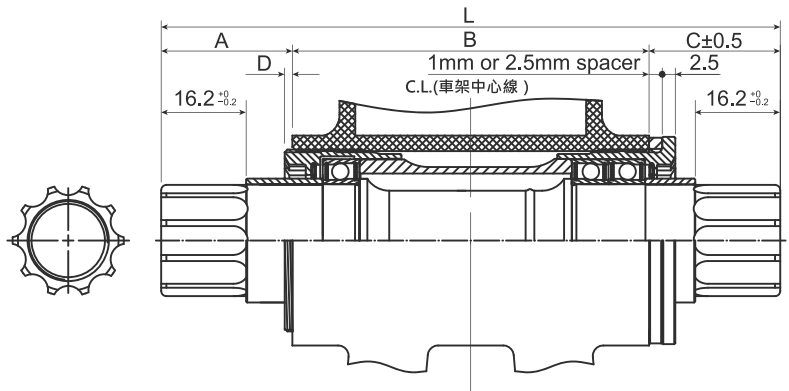

COMPONENTS	內容物	ISIS Spline Hollow Axle(SCM440), Cold Forged & CNC Machined Alloy Cups , w/Dust Seal,Alloy Body , Sealed Bearing 3pcs 鉻鉬鋼中空軸心, 鋁碗防塵套, 鋁中管, 培林x3
WEIGHT(LENGTH118)	重量(長度118)	242g
Threads	牙紋規格	BC 1.37"x24T R/L
B.B Shell Width	五通管寬度	68mm,73mm

LENGTH 中軸長度	B.B. SHELL WIDTH=68mm 五通管寬度 68mm				B.B. SHELL WIDTH=73mm 五通管寬度 73mm			BOLT THREAD 螺絲尺寸	
	L	A	B	C	D	A	B		C (w/o spacer)
108.0	20.0	68	20.0 (w/o SPACER)		0	Not Compatible (不相容)			M15xP1
113.0	22.5	68	22.5 (w/2.5mm spacer)		1.5	20.0	73	20.0	M15xP1
118.0	25.0	68	25.0(w/2.5mm spacer)		1.5	22.5	73	22.5	M15xP1
128.0	30.0	68	30.0(w/2.5mm spacer)		1.5	27.5	73	27.5	M12xP1
135.0	33.5	68	33.5(w/2.5mm spacer)		1.5	31.0	73	31.0	M12xP1

## B957

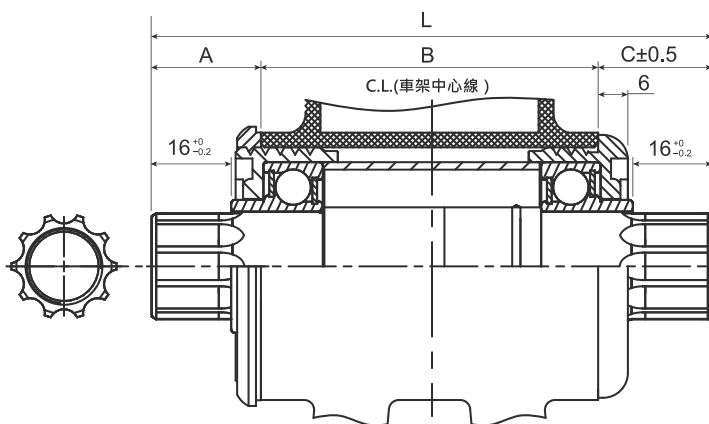

COMPONENTS	內容物	ISIS Spline Hollow Axle(SCM440) Cold Forged& CNC Machined with Alloy Cups w/Dust Seal Steel Body, Sealed Bearing 2pcs 鉻鉬鋼中空軸心, 鋁碗防塵套, 鐵中管, 培林x2
WEIGHT	重量	557g
Threads	牙紋規格	M48xP1.5 R/L
B.B Shell Width	五通管寬度	68mm

LENGTH 中軸長度	B.B. SHELL WIDTH=68mm 五通管寬度 68mm			BOLT THREAD 螺絲尺寸
L	A	B	C	
113.0	22	68	23	M12xP1

# BB401



MATERIAL	材質	Forged Alloy & CNC Machined External Cups 鋁碗 Plastic Center Sleeve 塑膠中管
SIZE	尺寸	English Threading 牙紋規格 (BC 1.37"x24T,R/L) for 68mm & 73mm Width 五通管寬度 (68mm&73mm) Oversized Sealed Bearing 密封式軸承 Ø24mm Spindle Ø24mm 軸心
FINISH	表面處理	Anodized Cups 陽極碗
WEIGHT	重量	106g
OPTIONAL	選配	Ceramic Bearing 陶瓷珠軸承
AVAILABLE SYSTEM	適用系統	SHIMANO

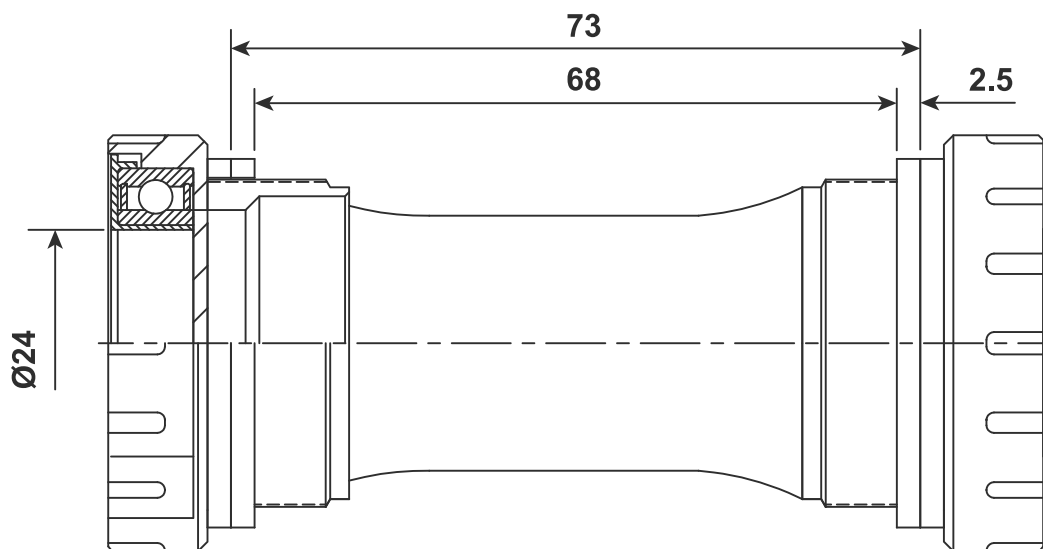

## BB501



MATERIAL	材質	Forged Alloy & CNC Machined External Cups 鋁碗 Plastic Center Sleeve 塑膠中管
SIZE	尺寸	English Threading 牙紋規格(BC 1.37"x24T, R/L) for 68mm & 73mm Width 五通管寬度(68mm&73mm) Oversized Sealed Bearing 密封式軸承 Spindle OD Left 軸心左端外徑(Crank-Side曲柄側): Ø 22mm Spindle OD Right 軸心右端外徑(Crainwheel-Side曲柄側): Ø 24mm
FINISH	表面處理	Anodized Cups 陽極碗
WEIGHT	重量	116g
OPTIONAL	選配	Ceramic Bearing 陶瓷珠軸承
AVAILABLE SYSTEM	適用系統	SRAM

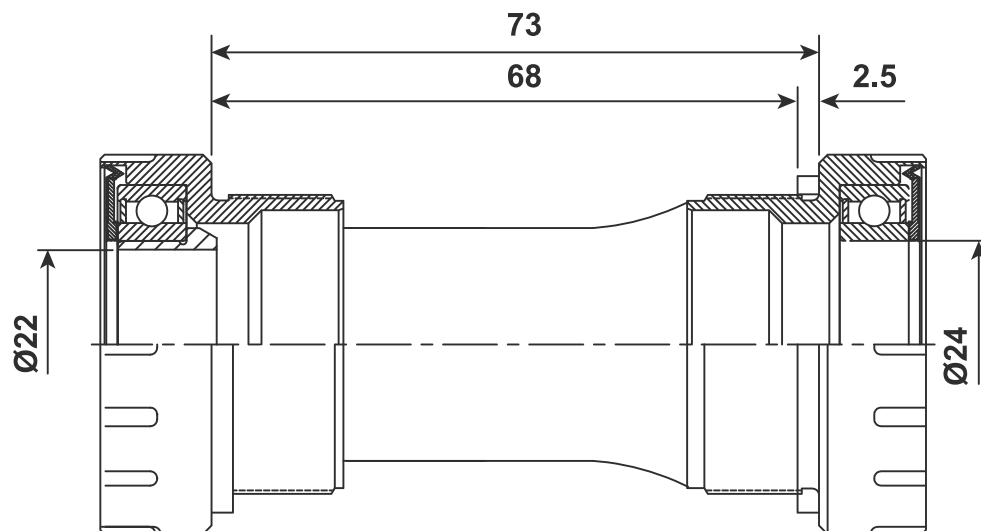

# BB86 / BB90 / BB92



## PRESS FIT TYPE 壓入式五通碗組

MATERIAL	材質	Forged Alloy & CNC Machined External Cups 鋁碗 Plastic Center Sleeve 塑膠中管
SIZE	尺寸	Ø24mm Spindle OD Ø24mm 軸心外徑
Available For	可適用於	86.5mm Frame B.B Shell Width 86.5mm寬之車架五通管 90mm Frame B.B Shell Width 90mm寬之車架五通管 92mm Frame B.B Shell Width 92mm寬之車架五通管 Press Fit Cups (壓入式碗 Ø41mm)
FINISH	表面處理	Anodized Cups 陽極碗
WEIGHT	重量	95g
BB SHELL ID	五通管內徑	Ø41mm

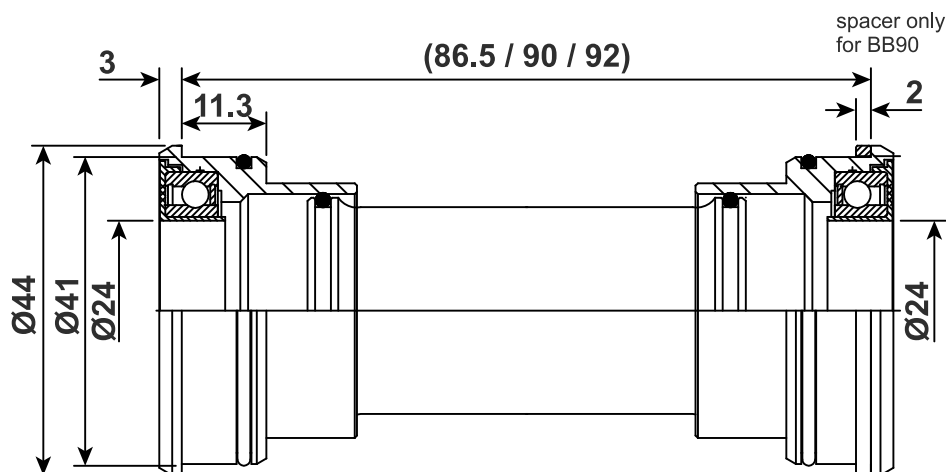

**BT4724 - 86 - 0S**

MATERIAL	材質	Alloy Cups And Body
Threads	牙紋規格	M47xP1.0
B.B Shell	五通	w86/92mm
Crank Spec	牙盤規格	For SHIMANO Ø24mm Crankset
Bearing	培林	Sealed Bearing 密封式培林
OPTIONAL	選配	Ceramic Bearing 陶瓷珠軸承
Available For Tool Notch	可用工具	Notch 16T O.D. 44mm

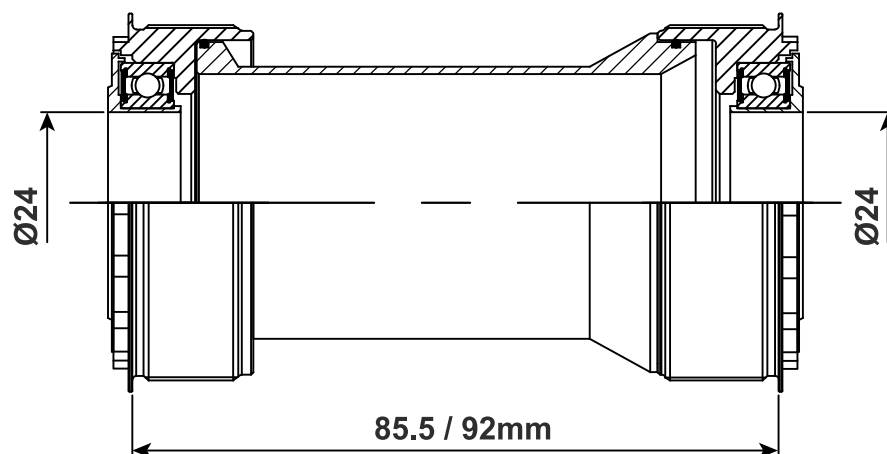

**BT4729 - 86 - 0S**

MATERIAL	材質	Alloy Cups And Body
Threads	牙紋規格	M47xP1.0
B.B Shell	五通	w86/92mm
Crank Spec	牙盤規格	For SRAM DUB Ø28.99mm Crankset
Bearing	培林	Sealed Bearing 密封式培林
OPTIONAL	選配	Ceramic Bearing 陶瓷珠軸承
Available For Tool Notch	可用工具	Notch 16T O.D. 48.5mm

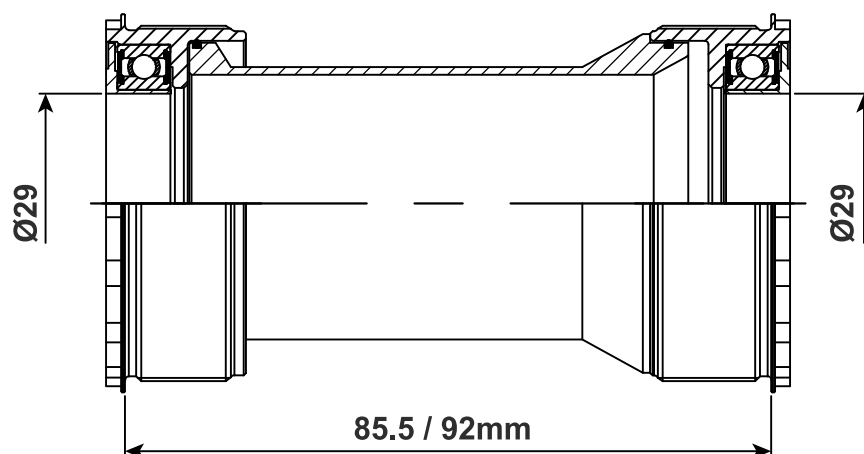

# BT4730 - 86 - 0S



MATERIAL	材質	Alloy Cups And Body
Threads	牙紋規格	M47xP1.0
B.B Shell	五通	w86/92mm
Crank Spec	牙盤規格	For Ø30mm Crankset
Bearing	培林	Sealed Bearing 密封式培林
OPTIONAL	選配	Ceramic Bearing 陶瓷珠軸承
Available For Tool Notch	可用工具	Notch 16T O.D. 48.5mm

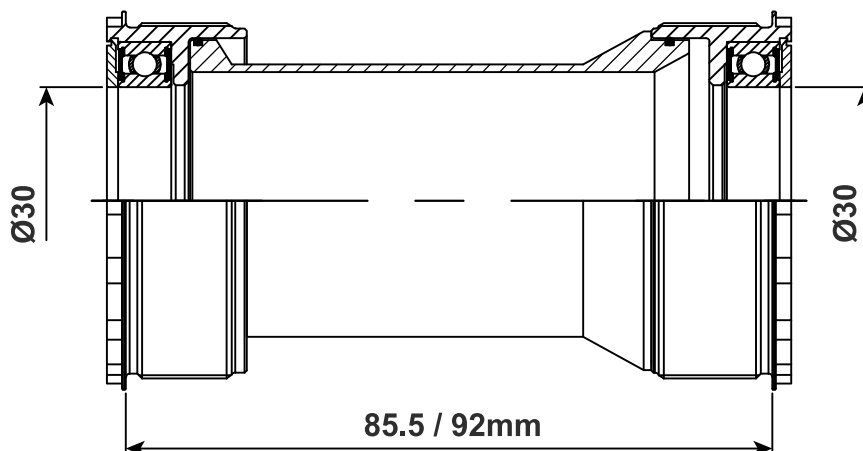

# BPF3024 - 68 - 0S



MATERIAL	材質	Alloy Cups And Body
Structure	結構	Center threaded locking on design 中心螺紋鎖固設計
B.B Shell	五通	w68/73mm x dia.46mm
Crank Spec	牙盤規格	For SHIMANO Ø24mm Crankset
Bearing	培林	Sealed Bearing 密封式培林
OPTIONAL	選配	Ceramic Bearing 陶瓷珠軸承
Available For Tool Notch	可用工具	Notch 16T O.D. 44mm

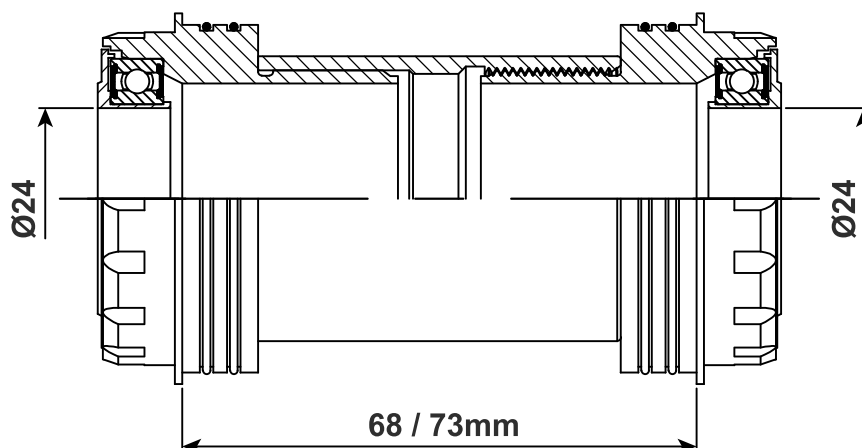

**B38624 - 86 - OS**

MATERIAL	材質	Alloy Cups And Body
Structure	結構	Center threaded locking on design 中心螺紋鎖固設計
B.B Shell	五通	w86/92mm x dia.46mm
Crank Spec	牙盤規格	For SHIMANO Ø24mm Crankset
Bearing	培林	Sealed Bearing 密封式培林
OPTIONAL	選配	Ceramic Bearing 陶瓷珠軸承
Available For Tool Notch	可用工具	Notch 16T O.D. 48.5mm

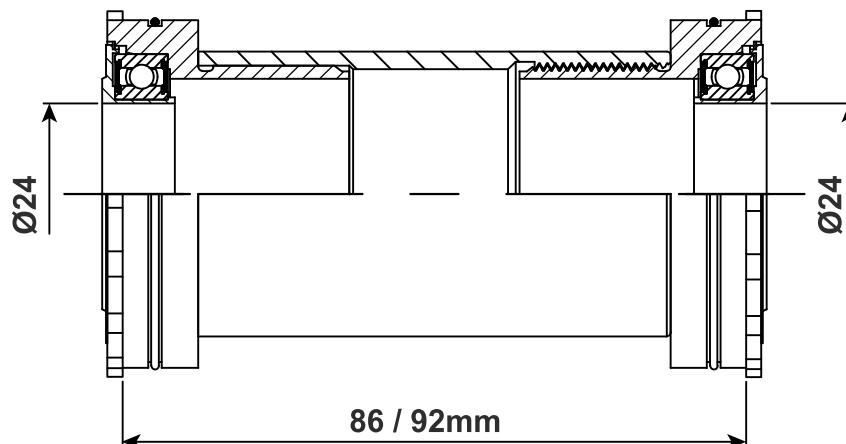

## B881



BSA 1.37"x 24T R/L

MATERIAL	材料	Steel, Set of 5pcs 鐵 x 5pcs
ROTATOR	轉動機構	Ball Retainers 珠巢 1/4"x9x2pcs
FINISH	表面處理	CP, UCP, ED, BK
APPLICATIONS	通用車種	Light Weight 輕便車, Mini Cycle 小車

## B882



BSA 1.37"x 24T R/L

MATERIAL	材料	Steel, Set of 5pcs 鐵 x 5pcs
ROTATOR	轉動機構	Ball Retainers 珠巢 1/4"x9x2pcs
FINISH	表面處理	CP, UCP, ED, BK
APPLICATIONS	通用車種	Light Weight 輕便車, Mini Cycle 小車

## B886



BSA 1.37"x 24T R/L

MATERIAL	材料	Steel, Set of 6pcs 鐵 x 6pcs
ROTATOR	轉動機構	Ball Retainers 珠巢 1/4"x9x2pcs
FINISH	表面處理	CP, UCP, ED, BK
APPLICATIONS	通用車種	Comfort(w/Chain Guard) 城市車 (加鏈條保護蓋)

## B887(B887B)



B887: BSA 1.37"x24T, R/L  
B887B: Italian 36mmx24T, R/R

MATERIAL	材料	Steel, Set of 5pcs 鐵 x 5pcs
ROTATOR	轉動機構	Ball Retainers 珠巢 1/4"x9x2pcs
FINISH	表面處理	CP, UCP, ED, BK
APPLICATIONS	通用車種	Light Weight 輕便車, Mini Cycle 小車

## B888



CUP SIZE	碗尺寸	Ø43mm
THREAD TYPE	牙紋	Left Cone: 3/4"un24T-LH Right Cone: 13/16"un24T
MATERIAL	材料	Steel, Set of 9pcs 鐵 x 9pcs
ROTATOR	轉動機構	Ball Retainers 珠巢 5/16"x7x2pcs
FINISH	表面處理	UCP, BK
APPLICATIONS	通用車種	Children Bike 童車

## B889



CUP SIZE	碗尺寸	Ø51.5mm
THREAD TYPE	牙紋	Left Cone: 7/8"un24T-LH Right Cone: 15/16"un24T
MATERIAL	材料	Steel, Set of 9pcs 鐵 x 9pcs
ROTATOR	轉動機構	Ball Retainers 珠巢 5/16"x9x2pcs
FINISH	表面處理	UCP, BK
APPLICATIONS	通用車種	BMX & Freestyle 表演車

## B890



CUP SIZE	碗尺寸	Ø45mm
THREAD TYPE	牙紋	Left Cone: 22un 24T-LH Right Cone: 23.2un 32T
MATERIAL	材料	Steel, Set of 10pcs 鐵 x 10pcs
ROTATOR	轉動機構	Ball Retainers 珠巢 1/4" x 11C x 2pcs
FINISH	表面處理	UCP, BK

## B890B



CUP SIZE	碗尺寸	Ø45mm
THREAD TYPE	牙紋	Left Cone: 22un 24T-LH Right Cone: 23.2un 32T
MATERIAL	材料	Steel, Set of 6pcs 鐵 x 6pcs
ROTATOR	轉動機構	Sealed Bearing 培林
FINISH	表面處理	UCP

# PEDALS

## 腳踏



# NECO



### WP-MC118

BODY 本體材質	Aluminum, CNC-machined body CNC精密加工鋁合金本體
AXLE 軸心材質	CNC-machined Cr-Mo CNC 精密加工鉻鉬鋼軸心
BEARING 轉動結構	LSL bushing & sealed 自潤軸承·密封式培林
BINDING 後蓋	Dual-sided Cr-Mo, tension adjustable 雙面鉻鉬鋼, 可依騎乘者喜好及使用習慣調整
CLEAT 扣片	WP-S01
SIZE 本體尺寸	103x96mm
WEIGHT 重量	204g/pair



### WP-MC120

BODY 本體材質	Aluminum, CNC-machined body CNC精密加工鋁合金本體
AXLE 軸心材質	CNC-machined Cr-Mo CNC 精密加工鉻鉬鋼軸心
BEARING 轉動結構	LSL bushing & sealed 自潤軸承·密封式培林
BINDING 後蓋	Dual-sided Cr-Mo, tension adjustable 雙面鉻鉬鋼, 可依騎乘者喜好及使用習慣調整
CLEAT 扣片	WP-S01
SIZE 本體尺寸	82x55mm
WEIGHT 重量	142g/pair



### WP321-N

BODY 本體材質	Aluminum 鋁
AXLE 軸心材質	Cr-Mo 鉻鉬鋼
BEARING 轉動結構	Sealed Bearing & Sleeve Bearing 密封式培林, 自潤軸承
SIZE 本體尺寸	87x53mm
WEIGHT 重量	184g/pair



### WP608S

BODY 本體材質	Aluminum 鋁
AXLE 軸心材質	Cr-Mo 鉻鉬鋼
BEARING 轉動結構	Sealed Bearing & Sleeve Bearing 密封式培林, 自潤軸承
SIZE 本體尺寸	82x105mm
WEIGHT 重量	271g/pair



### WP701D

BODY 本體材質	Aluminum 鋁
AXLE 軸心材質	Cr-Mo 鉻鉬鋼
BEARING 轉動結構	Sealed Bearing & Sleeve Bearing 密封式培林, 自潤軸承
SIZE 本體尺寸	93x98mm
WEIGHT 重量	340g/pair



### WP702D

BODY 本體材質	Aluminum 鋁
AXLE 軸心材質	Cr-Mo 鉻鉬鋼
BEARING 轉動結構	Sealed Bearing & Sleeve Bearing 密封式培林, 自潤軸承
SIZE 本體尺寸	109x121mm
WEIGHT 重量	349g/pair



### WP703S

BODY 本體材質	Aluminum 鋁
AXLE 軸心材質	Cr-Mo 鉻鉬鋼
BEARING 轉動結構	Sealed Bearing 密封式培林
SIZE 本體尺寸	110x105mm
WEIGHT 重量	327g/pair



### WP704D

BODY 本體材質	Aluminum 鋁
AXLE 軸心材質	Cr-Mo 鉻鉬鋼
BEARING 轉動結構	Sealed Bearing & Sleeve Bearing 密封式培林, 自潤軸承
SIZE 本體尺寸	88x99mm
WEIGHT 重量	219g/pair

# NECO PEDALS

腳踏 PEDALS



## WP706D

BODY	本體材質	Aluminum 鋁
AXLE	軸心材質	Cr-Mo 鉻鉬鋼
BEARING	轉動結構	Sealed Bearing & Sleeve Bearing 密封式培林, 自潤軸承
SIZE	本體尺寸	101x119mm
WEIGHT	重量	342g/pair



## WP720D

BODY	本體材質	Aluminum 鋁
AXLE	軸心材質	Cr-Mo 鉻鉬鋼
BEARING	轉動結構	Sealed Bearing & Sleeve Bearing 密封式培林, 自潤軸承
SIZE	本體尺寸	100x105mm
WEIGHT	重量	303g/pair



## WP721S

BODY	本體材質	Aluminum 鋁
AXLE	軸心材質	Cr-Mo 鉻鉬鋼
BEARING	轉動結構	Sealed Bearing & Sleeve Bearing 密封式培林, 自潤軸承
SIZE	本體尺寸	100x116mm
WEIGHT	重量	298g/pair



## WP722

BODY	本體材質	Aluminum 鋁
AXLE	軸心材質	Cr-Mo 鉻鉬鋼
BEARING	轉動結構	Sealed Bearing*3 密封式培林3PCS
SIZE	本體尺寸	99x118mm
WEIGHT	重量	360g/pair



## WP725D

BODY	本體材質	Aluminum 鋁
AXLE	軸心材質	Cr-Mo 鉻鉬鋼
BEARING	轉動結構	Sealed Bearing & Sleeve Bearing 密封式培林, 自潤軸承
SIZE	本體尺寸	90x102mm
WEIGHT	重量	213g/pair



## WP728D

BODY	本體材質	Aluminum 鋁
AXLE	軸心材質	Cr-Mo 鉻鉬鋼
BEARING	轉動結構	Sealed Bearing & Sleeve Bearing 密封式培林, 自潤軸承
SIZE	本體尺寸	90x106mm
WEIGHT	重量	209g/pair



## WP729D

BODY	本體材質	Aluminum 鋁
AXLE	軸心材質	Cr-Mo 鉻鉬鋼
BEARING	轉動結構	Sealed Bearing & Sleeve Bearing 密封式培林, 自潤軸承
SIZE	本體尺寸	85x100mm
WEIGHT	重量	255g/pair



## WP769S

BODY	本體材質	Aluminum 鋁
AXLE	軸心材質	Cr-Mo 鉻鉬鋼
BEARING	轉動結構	Sealed Bearing & Sleeve Bearing 密封式培林, 自潤軸承
SIZE	本體尺寸	97x118mm
WEIGHT	重量	343g/pair



## WP902

BODY	本體材質	Aluminum 鋁
AXLE	軸心材質	Cr-Mo 鉻鉬鋼
BEARING	轉動結構	Sealed Bearing & Sleeve Bearing 密封式培林, 自潤軸承
SIZE	本體尺寸	108x105mm
WEIGHT	重量	384g/pair



### WP903

BODY	本體材質	Aluminum 鋁
AXLE	軸心材質	Cr-Mo 鉻鉬鋼
BEARING	轉動結構	Sealed Bearing & Sleeve Bearing 密封式培林, 自潤軸承
SIZE	本體尺寸	108x100mm
WEIGHT	重量	372g/pair



### WP904

BODY	本體材質	Aluminum 鋁
AXLE	軸心材質	Cr-Mo 鉻鉬鋼
BEARING	轉動結構	Sealed Bearing & Sleeve Bearing 密封式培林, 自潤軸承
SIZE	本體尺寸	108x105mm
WEIGHT	重量	382g/pair



### WP580

BODY	本體材質	Aluminum+PP Body With Inlaid Anti-Slip Rubber 鋁+防滑橡膠
AXLE	軸心材質	Cr-Mo 鉻鉬鋼
BEARING	轉動結構	Sleeve Bearing 自潤軸承
SIZE	本體尺寸	<b>98x79mm</b>
WEIGHT	重量	365/pair



### WP908A

BODY	本體材質	Aluminum 鋁
AXLE	軸心材質	Cr-Mo 鉻鉬鋼
BEARING	轉動結構	Sealed Bearing & Sleeve Bearing 密封式培林, 自潤軸承
SIZE	本體尺寸	108x108mm
WEIGHT	重量	522g/pair



### WP101

BODY	本體材質	Aluminum 鋁
AXLE	軸心材質	Cr-Mo 鉻鉬鋼
BEARING	轉動結構	Sealed Bearing & Sleeve Bearing 密封式培林, 自潤軸承
SIZE	本體尺寸	103x63mm
WEIGHT	重量	273g/pair



### WP97D

BODY	本體材質	Aluminum 鋁
AXLE	軸心材質	Steel 鐵
BEARING	轉動結構	Ball Bearing 珠巢
SIZE	本體尺寸	103x63mm
WEIGHT	重量	397g/pair



### WP625

BODY	本體材質	Aluminum 鋁
AXLE	軸心材質	Steel 鐵
BEARING	轉動結構	Ball Bearing 珠巢
SIZE	本體尺寸	<b>109x96mm</b>
WEIGHT	重量	435g/pair



### WP97

BODY	本體材質	Aluminum 鋁
AXLE	軸心材質	Steel 鐵
BEARING	轉動結構	Ball Bearing 珠巢
SIZE	本體尺寸	120x85mm
WEIGHT	重量	390g/pair



### WP908-2

BODY	本體材質	Aluminum 鋁
AXLE	軸心材質	Steel 鐵
BEARING	轉動結構	Ball Bearing 珠巢
SIZE	本體尺寸	<b>109x105mm</b>
WEIGHT	重量	460g/pair

# NECO PEDALS

腳踏 PEDALS



## WP303

BODY	本體材質	Aluminum 鋁
AXLE	軸心材質	Steel 鐵
BEARING	轉動結構	Ball Bearing 珠巢
SIZE	本體尺寸	<b>110x104mm</b>
WEIGHT	重量	440g/pair



## WP313

BODY	本體材質	Aluminum 鋁
AXLE	軸心材質	Steel 鐵
BEARING	轉動結構	Ball Bearing 珠巢
SIZE	本體尺寸	<b>109x100mm</b>
WEIGHT	重量	449g/pair

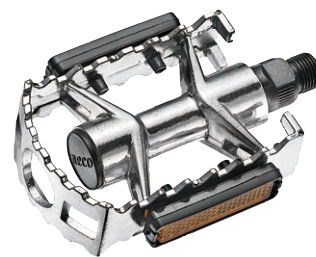

## WP893

BODY	本體材質	Aluminum 鋁
AXLE	軸心材質	Steel 鐵
BEARING	轉動結構	Ball Bearing 珠巢
SIZE	本體尺寸	103x62mm
WEIGHT	重量	402g/pair



## WP895

BODY	本體材質	Aluminum 鋁
AXLE	軸心材質	Steel 鐵
BEARING	轉動結構	Ball Bearing 珠巢
SIZE	本體尺寸	<b>104x77mm</b>
WEIGHT	重量	459g/pair



## WP897

BODY	本體材質	Aluminum 鋁
AXLE	軸心材質	Steel 鐵
BEARING	轉動結構	Ball Bearing 珠巢
SIZE	本體尺寸	105x76mm
WEIGHT	重量	399g/pair



## WP916

BODY	本體材質	Aluminum 鋁
AXLE	軸心材質	Steel 鐵
BEARING	轉動結構	Ball Bearing 珠巢
SIZE	本體尺寸	<b>113x108mm</b>
WEIGHT	重量	510g/pair



## WP931A/S

BODY	本體材質	PP 塑料聚丙稀
CAGE	外框	WP931A:Aluminum 鋁 WP931S:Steel 鐵
AXLE	軸心材質	Steel 鐵
BEARING	轉動結構	Ball Bearing 珠巢
SIZE	本體尺寸	<b>103x79mm</b>
WEIGHT	重量	Aluminum 鋁:342.5g/pair Steel 鐵:405.5g/pair

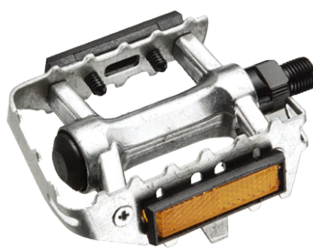

## WP932

BODY	本體材質	Aluminum 鋁
CAGE	外框	Aluminum 鋁
AXLE	軸心材質	Steel 鐵
BEARING	轉動結構	Ball Bearing 珠巢
SIZE	本體尺寸	<b>102x81mm</b>
WEIGHT	重量	336g/pair

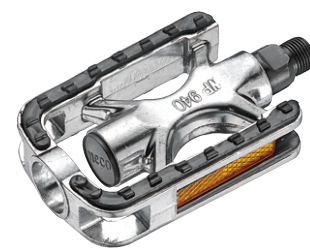

## WP940

BODY	本體材質	PP+Aluminum 塑料聚丙稀+鋁
AXLE	軸心材質	Steel 鐵
BEARING	轉動結構	Ball Bearing 珠巢
SIZE	本體尺寸	<b>109x68mm</b>
WEIGHT	重量	425g/pair



### WP940-1

BODY 本體材質	PP 塑料聚丙稀+Aluminum 鋁
AXLE 軸心材質	Steel 鐵
BEARING 轉動結構	Ball Bearing 珠巢
SIZE 本體尺寸	<b>101x76mm</b>
WEIGHT 重量	401.5g/pair



### WP201A/S

BODY 本體材質	Plastic 塑膠
CAGE 外框	WP201A:Aluminum鋁 WP201S:Steel鐵
AXLE 軸心材質	Steel 鐵
BEARING 轉動結構	Ball Bearing 珠巢
SIZE 本體尺寸	<b>102x63mm</b>
WEIGHT 重量	Aluminum鋁:332g/pair Steel鐵:425g/pair



### WP502

BODY 本體材質	PP 塑料聚丙稀
AXLE 軸心材質	Steel 鐵
BEARING 轉動結構	Sleeve Bearing 自潤軸承
SIZE 本體尺寸	<b>105x97mm</b>
WEIGHT 重量	273g/pair
OPTIONAL 備註	WP520-1 Ball Bearing 珠巢:320g/pair



### WP601

BODY 本體材質	PC Body 聚碳酸酯
AXLE 軸心材質	Steel 鐵
BEARING 轉動結構	Ball Bearing 珠巢
SIZE 本體尺寸	110x100mm
WEIGHT 重量	415g/pair
可選顏色 AVAILABLE FINISH	Transparent Clear透明 / Red紅 / Blue藍 / Purple紫 / Green綠 / Yellow黃



### WP208

BODY 本體材質	One-Piece Black PP+ Grey Rubber 一體成型塑膠+灰橡膠
AXLE 軸心材質	Steel 鐵
BEARING 轉動結構	Ball Bearing 珠巢
SIZE 本體尺寸	114x85mm
WEIGHT 重量	404.5g/pair



### WP108

BODY 本體材質	One-Piece Black PP+ Grey Rubber 一體成型塑膠+灰橡膠
AXLE 軸心材質	Steel 鐵
BEARING 轉動結構	Ball Bearing 珠巢
SIZE 本體尺寸	111x85mm
WEIGHT 重量	380g/pair



### WP940-2

BODY 本體材質	PP 塑料聚丙稀
AXLE 軸心材質	Steel 鐵
BEARING 轉動結構	Ball Bearing 珠巢
SIZE 本體尺寸	100x86mm
WEIGHT 重量	326g/pair



### WP302

BODY 本體材質	One-Piece Black PP+ Grey Rubber 一體成型塑膠+灰橡膠
AXLE 軸心材質	Steel 鐵
BEARING 轉動結構	Ball Bearing 珠巢
SIZE 本體尺寸	<b>109x73mm</b>
WEIGHT 重量	375.5g/pair



### WP301

BODY 本體材質	PP 塑料聚丙稀
AXLE 軸心材質	Steel 鐵
BEARING 轉動結構	Ball Bearing 珠巢
SIZE 本體尺寸	<b>108x74mm</b>
WEIGHT 重量	336.5g/pair

# NECO PEDALS

腳踏 PEDALS



## WP402

BODY 本體材質	PP 塑料聚丙稀
AXLE 軸心材質	Steel 鐵
BEARING 轉動結構	Ball Bearing 珠巢
SIZE 本體尺寸	<b>62x87mm</b>
WEIGHT 重量	245g/pair



## WP195

BODY 本體材質	PP 塑料聚丙稀
AXLE 軸心材質	Steel 鐵
BEARING 轉動結構	Ball Bearing 珠巢
SIZE 本體尺寸	<b>109x87mm</b>
WEIGHT 重量	314g/pair



## WP188

BODY 本體材質	PP 塑料聚丙稀
AXLE 軸心材質	Steel 鐵
BEARING 轉動結構	Ball Bearing 珠巢
SIZE 本體尺寸	<b>110x73mm</b>
WEIGHT 重量	320g/pair



## WP178

BODY 本體材質	PP 塑料聚丙稀
AXLE 軸心材質	Steel 鐵
BEARING 轉動結構	Ball Bearing 珠巢
SIZE 本體尺寸	<b>109x78mm</b>
WEIGHT 重量	333.5g/pair



## WP403

BODY 本體材質	PP 塑料聚丙稀
AXLE 軸心材質	Steel 鐵
BEARING 轉動結構	Ball Bearing 珠巢
SIZE 本體尺寸	<b>108x95mm</b>
WEIGHT 重量	345g/pair



## WP128

BODY 本體材質	PP 塑料聚丙稀
AXLE 軸心材質	Steel 鐵
BEARING 轉動結構	Ball-less 無珠
SIZE 本體尺寸	<b>96x59mm</b>
WEIGHT 重量	222g/pair



## WP941-1

BODY 本體材質	PP 塑料聚丙稀
AXLE 軸心材質	Steel 鐵
BEARING 轉動結構	Ball Bearing 珠巢
SIZE 本體尺寸	<b>114x70mm</b>
WEIGHT 重量	400g/pair



## WP303-1

BODY 本體材質	PP 塑料聚丙稀
AXLE 軸心材質	Steel 鐵
BEARING 轉動結構	Ball Bearing 珠巢
SIZE 本體尺寸	<b>109x69mm</b>
WEIGHT 重量	323g/pair



## WP501

BODY 本體材質	PP 塑料聚丙稀
AXLE 軸心材質	Steel 鐵
BEARING 轉動結構	Self Moistening 自潤軸套
SIZE 本體尺寸	<b>102x90mm</b>
WEIGHT 重量	253g/pair



### WP138

BODY 本體材質	PP 塑料聚丙稀
AXLE 軸心材質	Steel 鐵
BEARING 轉動結構	Ball Bearing 珠巢
SIZE 本體尺寸	<b>91x63mm</b>
WEIGHT 重量	295g/pair

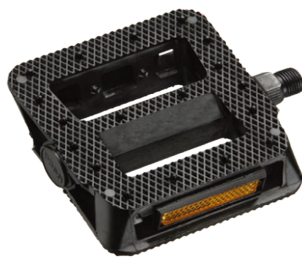

### WP406

BODY 本體材質	PP 塑料聚丙稀
AXLE 軸心材質	Steel 鐵
BEARING 轉動結構	Ball Bearing 珠巢
SIZE 本體尺寸	<b>109x115mm</b>
WEIGHT 重量	411g/pair



### WP408

BODY 本體材質	PP 塑料聚丙稀
AXLE 軸心材質	Steel 鐵
BEARING 轉動結構	Ball Bearing 珠巢
SIZE 本體尺寸	<b>110x96mm</b>
WEIGHT 重量	360g/pair



### WP401

BODY 本體材質	PP 塑料聚丙稀
AXLE 軸心材質	Steel 鐵
BEARING 轉動結構	Ball Bearing 珠巢
SIZE 本體尺寸	111x100mm
WEIGHT 重量	343.5g/pair



### WP168

BODY 本體材質	PP 塑料聚丙稀
AXLE 軸心材質	Steel 鐵
BEARING 轉動結構	Ball Bearing 珠巢
SIZE 本體尺寸	110x84mm
WEIGHT 重量	296.5g/pair
OPTIONAL 備註	WP168B(Ball-less無珠) Steel Axle 鐵軸心 272g/pair



### WP163

BODY 本體材質	PP 塑料聚丙稀
AXLE 軸心材質	Steel 鐵
BEARING 轉動結構	Ball Bearing 珠巢
SIZE 本體尺寸	114x85mm
WEIGHT 重量	310g/pair



### WP251

BODY 本體材質	PP 塑料聚丙稀
AXLE 軸心材質	Steel 鐵
BEARING 轉動結構	Ball Bearing 珠巢
SIZE 本體尺寸	<b>99x76mm</b>
WEIGHT 重量	287g/pair



### WP190

BODY 本體材質	PP 塑料聚丙稀
AXLE 軸心材質	Steel 鐵
BEARING 轉動結構	Ball Bearing 珠巢
SIZE 本體尺寸	<b>109x72mm</b>
WEIGHT 重量	337.5g/pair



### WP148

BODY 本體材質	PP 塑料聚丙稀
AXLE 軸心材質	Steel 鐵
BEARING 轉動結構	Ball Bearing 珠巢
SIZE 本體尺寸	<b>92x62mm</b>
WEIGHT 重量	281g/pair
OPTIONAL 備註	WP148B(Ball-less無珠) Steel Axle 鐵軸心 248g/pair

# HUBS

## 花鼓



**NECO**



## RA01FDQ2

HUB SHELL	外殼材質	Aluminum 鋁
AXLE MATERIAL	軸心材質	Aluminum 鋁 STD length 軸心長:108mm
SEALED BEARING Q'TY	培林數	2
OLD	叉寬	100mm
PCD	孔距	38mm
SPOKE HOLES	孔數	13G/14Gx16H/20H/24H/28H/32H/36H
WEIGHT	重量	139g

Available hole style: Key shape hole or oval shape hole; hole to hole or hole against hole. 可選鑰匙孔或圓孔, 錯孔或對孔

REMARKS	備註
---------	----



## RA01RDQ4

HUB SHELL	外殼材質	Aluminum 鋁
AXLE MATERIAL	軸心材質	Aluminum 鋁 STD length 軸心長:145mm
SEALED BEARING Q'TY	培林數	4
OLD	叉寬	130mm
PCD	孔距	53mm
SPOKE HOLES	孔數	13G/14Gx16H/20H/24H/28H/32H/36H
WEIGHT	重量	320.2g

Available speed: 7/8/9-speed, 10-speed will include washer (1.85mm thick), 11 speed will include longer cassette (1.85mm) 適用7/8/9速, 10速多華司, 11速用長棘輪

REMARKS	備註
---------	----



## RA02FDQ2

HUB SHELL	外殼材質	Aluminum 鋁
AXLE MATERIAL	軸心材質	Aluminum 鋁 STD length 軸心長:108mm
SEALED BEARING Q'TY	培林數	2
OLD	叉寬	100mm
PCD	孔距	38mm
SPOKE HOLES	孔數	13G/14Gx16H/20H/24H/28H/32H/36H
WEIGHT	重量	137.8g

Available hole style: Key shape hole or oval shape hole; hole to hole or hole against hole. 可選鑰匙孔或圓孔, 錯孔或對孔

REMARKS	備註
---------	----



## RA02RDQ4

HUB SHELL	外殼材質	Aluminum 鋁
AXLE MATERIAL	軸心材質	Aluminum 鋁 STD length 軸心長:145mm
SEALED BEARING Q'TY	培林數	4
OLD	叉寬	130mm
PCD	孔距	53mm
SPOKE HOLES	孔數	13G/14Gx16H/20H/24H/28H/32H/36H
WEIGHT	重量	317.8g

Available speed: 7/8/9-speed, 10-speed will include washer (1.85mm thick), 11 speed will include longer cassette (1.85mm) 適用7/8/9速, 10速多華司, 11速用長棘輪

REMARKS	備註
---------	----



## RA03FDQ2

HUB SHELL	外殼材質	Aluminum 鋁
AXLE MATERIAL	軸心材質	Aluminum 鋁 STD length 軸心長:108mm
SEALED BEARING Q'TY	培林數	2
OLD	叉寬	100mm
PCD	孔距	38mm
SPOKE HOLES	孔數	13G/14Gx16H/20H/24H/28H/32H/36H
WEIGHT	重量	139.9g

Available hole style: Key shape hole or oval shape hole; hole to hole or hole against hole. 可選鑰匙孔或圓孔, 錯孔或對孔

REMARKS	備註	
---------	----	--



## RA03RDQ4

HUB SHELL	外殼材質	Aluminum 鋁
AXLE MATERIAL	軸心材質	Aluminum 鋁 STD length 軸心長:145mm
SEALED BEARING Q'TY	培林數	4
OLD	叉寬	130mm
PCD	孔距	53mm
SPOKE HOLES	孔數	13G/14Gx16H/20H/24H/28H/32H/36H
WEIGHT	重量	327.4g

Available speed: 7/8/9-speed, 10-speed will include washer (1.85mm thick), 11 speed will include longer cassette (1.85mm) 適用7/8/9速, 10速多華司, 11速用長棘輪

REMARKS	備註	
---------	----	--



## MS03FDQ2

HUB SHELL	外殼材質	Aluminum 鋁
AXLE MATERIAL	軸心材質	Aluminum 鋁
SEALED BEARING Q'TY	培林數	2
OLD	叉寬	100mm
PCD	孔距	58mm
SPOKE HOLES	孔數	13G/14Gx20H/24H/28H/32H/36H
		MA03FDQ2:W/Aluminum Axle & Cover
UPGRADE	可選配項目	鋁軸心&側蓋
WEIGHT	重量	274g
FINISH	表面處理	Silver & Black, 銀&黑



## MS03RDQ4

HUB SHELL	外殼材質	Aluminum 鋁
AXLE MATERIAL	軸心材質	Aluminum 鋁
SEALED BEARING Q'TY	培林數	4
OLD	叉寬	135mm
PCD	孔距	58mm
SPOKE HOLES	孔數	13G/14Gx20H/24H/28H/32H/36H
		MA03RDQ2:W/Aluminum Axle & Cover
UPGRADE	可選配項目	鋁軸心&側蓋
WEIGHT	重量	353g
FINISH	表面處理	Silver & Black, 銀&黑



## MS07FDQ2

HUB SHELL	外殼材質	Aluminum 鋁
AXLE MATERIAL	軸心材質	Aluminum 鋁
SEALED BEARING Q'TY	培林數	2
OLD	叉寬	100mm
PCD	孔距	58mm
SPOKE HOLES	孔數	13G/14Gx20H/24H/28H/32H/36H
MA07FDQ2:W/Aluminum Axle & Cover		
UPGRADE	可選配項目	鋁軸心&側蓋
WEIGHT	重量	263g
FINISH	表面處理	Silver & Black, 銀&黑



## MS07RDQ4

HUB SHELL	外殼材質	Aluminum 鋁
AXLE MATERIAL	軸心材質	Aluminum 鋁
SEALED BEARING Q'TY	培林數	4
OLD	叉寬	135mm
PCD	孔距	58mm
SPOKE HOLES	孔數	13G/14Gx20H/24H/28H/32H/36H
MA07RDQ2:W/Aluminum Axle & Cover		
UPGRADE	可選配項目	鋁軸心&側蓋
WEIGHT	重量	340g
FINISH	表面處理	Silver & Black, 銀&黑

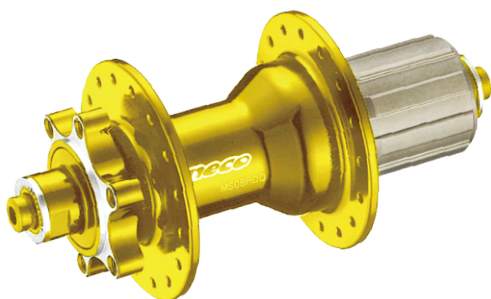

## MS08RDQ4

HUB SHELL	外殼材質	Aluminum 鋁
AXLE MATERIAL	軸心材質	Aluminum 鋁
SEALED BEARING Q'TY	培林數	4
OLD	叉寬	135mm
PCD	孔距	58mm
SPOKE HOLES	孔數	13G/14Gx20H/24H/28H/32H/36H
MA08RDQ2:W/Aluminum Axle & Cover		
UPGRADE	可選配項目	鋁軸心&側蓋
WEIGHT	重量	341g
FINISH	表面處理	Silver & Black, 銀&黑

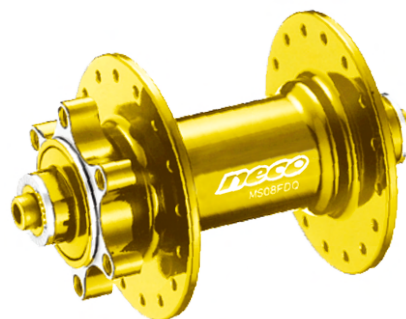

## MS08FDQ2

HUB SHELL	外殼材質	Aluminum 鋁
AXLE MATERIAL	軸心材質	Aluminum 鋁
SEALED BEARING Q'TY	培林數	2
OLD	叉寬	100mm
PCD	孔距	58mm
SPOKE HOLES	孔數	13G/14Gx20H/24H/28H/32H/36H
MA08FDQ2:W/Aluminum Axle & Cover		
UPGRADE	可選配項目	鋁軸心&側蓋
WEIGHT	重量	210g
FINISH	表面處理	Silver & Black, 銀&黑



## MS09FDQ2

HUB SHELL	外殼材質	Aluminum 鋁
AXLE MATERIAL	軸心材質	Aluminum 鋁
SEALED BEARING Q'TY	培林數	2
OLD	叉寬	100mm
PCD	孔距	58mm
SPOKE HOLES	孔數	13G/14Gx24H/28H/32H/36H
MA09FDQ2:W/Aluminum Axle & Cover		
UPGRADE	可選配項目	鋁軸心&側蓋
WEIGHT	重量	197g
FINISH	表面處理	Silver & Black, 銀&黑



## MS09RDQ4

HUB SHELL	外殼材質	Aluminum 鋁
AXLE MATERIAL	軸心材質	Aluminum 鋁
SEALED BEARING Q'TY	培林數	4
OLD	叉寬	135mm
PCD	孔距	58mm
SPOKE HOLES	孔數	13G/14Gx24H/28H/32H/36H
MA09RDQ2:W/Aluminum Axle & Cover		
UPGRADE	可選配項目	鋁軸心&側蓋
WEIGHT	重量	418g
FINISH	表面處理	Silver & Black, 銀&黑

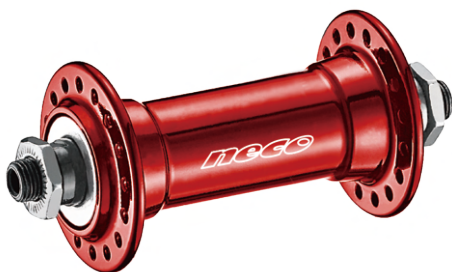

## MS641F

HUB SHELL	外殼材質	Aluminum 鋁
AXLE MATERIAL	軸心材質	SC45
OLD	叉寬	100mm
PCD	孔距	38mm
ROLLING SYSTEM	轉動機構	Loose Ball 散珠
SPOKE HOLES	孔數	13G/14Gx24H/28H/32H/36H
WEIGHT	重量	155g
REMARKS	備註	black/sliver/blue/golden 黑/銀/藍/金

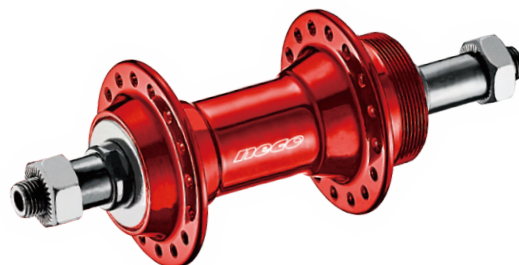

## MS641R

HUB SHELL	外殼材質	Aluminum 鋁
AXLE MATERIAL	軸心材質	SC45
OLD	叉寬	135mm
PCD	孔距	45mm
ROLLING SYSTEM	轉動機構	Loose Ball 散珠
SPOKE HOLES	孔數	13G/14Gx24H/28H/32H/36H
WEIGHT	重量	245g
REMARKS	備註	black/sliver/blue/golden 黑/銀/藍/金



### MS3951F

HUB SHELL	外殼材質	Aluminum 鋁
AXLE MATERIAL	軸心材質	SC45
OLD	叉寬	100mm
PCD	孔距	58mm
ROLLING SYSTEM	轉動機構	Loose Ball 散珠螺紋式
SPOKE HOLES	孔數	13G/14Gx24H/28H/32H/36H
WEIGHT	重量	270g
REMARKS	備註	black/sliver/blue/golden 黑/銀/藍/金

### MS3951R

HUB SHELL	外殼材質	Aluminum 鋁
AXLE MATERIAL	軸心材質	SC45
OLD	叉寬	135mm
PCD	孔距	58mm
ROLLING SYSTEM	轉動機構	Loose Ball 散珠螺紋式
SPOKE HOLES	孔數	13G/14Gx24H/28H/32H/36H
WEIGHT	重量	475g
REMARKS	備註	black/sliver/blue/golden 黑/銀/藍/金



### MS37F

HUB SHELL	外殼材質	Aluminum 鋁
AXLE MATERIAL	軸心材質	SC45
OLD	叉寬	100mm
PCD	孔距	58mm
ROLLING SYSTEM	轉動機構	Loose Ball 散珠
SPOKE HOLES	孔數	13G/14G*x24H/28H/32H/36H
WEIGHT	重量	276g
REMARKS	備註	black/sliver/blue/golden 黑/銀/藍/金

### MS37R

HUB SHELL	外殼材質	Aluminum 鋁
AXLE MATERIAL	軸心材質	SC45
OLD	叉寬	135mm
PCD	孔距	58mm
ROLLING SYSTEM	轉動機構	Loose Ball 散珠
SPOKE HOLES	孔數	13G/14Gx24H/28H/32H/36H
WEIGHT	重量	332g
REMARKS	備註	black/sliver/blue/golden 黑/銀/藍/金



## MS373F

HUB SHELL	外殼材質	Aluminum 鋁
AXLE MATERIAL	軸心材質	SC45
OLD	叉寬	100mm
PCD	孔距	58mm
ROLLING SYSTEM	轉動機構	Loose Ball 散珠
SPOKE HOLES	孔數	13G/14Gx24H/28H/32H/36H
WEIGHT	重量	279g



## MS373R

HUB SHELL	外殼材質	Aluminum 鋁
AXLE MATERIAL	軸心材質	SC45
OLD	叉寬	135mm
PCD	孔距	58mm
ROLLING SYSTEM	轉動機構	Loose Ball 散珠
SPOKE HOLES	孔數	13G/14Gx24H/28H/32H/36H
WEIGHT	重量	459g



## MS38F

HUB SHELL	外殼材質	Aluminum 鋁
AXLE MATERIAL	軸心材質	SC45
OLD	叉寬	100mm
PCD	孔距	58mm
ROLLING SYSTEM	轉動機構	Loose Ball 散珠
SPOKE HOLES	孔數	13G/14Gx24H/28H/32H/36H
WEIGHT	重量	287g
REMARKS	備註	black/sliver/blue/golden 黑/銀/藍/金



## MS38R

HUB SHELL	外殼材質	Aluminum 鋁
AXLE MATERIAL	軸心材質	SC45
OLD	叉寬	135mm
PCD	孔距	58mm
ROLLING SYSTEM	轉動機構	Loose Ball 散珠
SPOKE HOLES	孔數	13G/14Gx24H/28H/32H/36H
WEIGHT	重量	465g
REMARKS	備註	black/sliver/blue/golden 黑/銀/藍/金



## HA102F

HUB SHELL	外殼材質	Aluminum 鋁
AXLE MATERIAL	軸心材質	SC45
OLD	叉寬	135mm
PCD	孔距	58mm
ROLLING SYSTEM	轉動機構	Loose Ball 散珠
SPOKE HOLES	孔數	12G/13Gx32Hx36H
WEIGHT	重量	316g



## HA450F-100

HUB SHELL	外殼材質	Aluminum 鋁
OLD	叉寬	100mm/110mm
PCD	孔距	58mm
SEALED BEARING Q'TY	培林數	2
SPOKE HOLES	孔數	13Gx32H/36H
WEIGHT	重量	218g



## HA450F-150

HUB SHELL	外殼材質	Aluminum 鋁
OLD	叉寬	150mm
PCD	孔距	58mm
SEALED BEARING Q'TY	培林數	2
SPOKE HOLES	孔數	12G/13Gx32Hx36H
WEIGHT	重量	280g



## HA450R

HUB SHELL	外殼材質	Aluminum 鋁
OLD	叉寬	142mm/148mm
PCD	孔距	58mm
SEALED BEARING Q'TY	培林數	4
SPOKE HOLES	孔數	13Gx32H/36H
WEIGHT	重量	358g



## KTG12

MATERIAL	材質	Aluminum 鋁
LENGTH	長度	120mm/121mm/123mm/125mm 142mm/162mm/164mm/165mm 168mm/171mm/173mm/175mm
THREAD	牙紋	M12,M15



## Q01

MATERIAL	材質	Aluminum 鋁
AXLE	軸心	Steel 鐵
WEIGHT	重量	FRONT 前: 51.5g REAR 後: 57.5g



## Q07

MATERIAL	材質	Aluminum 鋁
AXLE	軸心	Steel 鐵
WEIGHT	重量	FRONT 前: 56g REAR 後: 62g



## Q17

MATERIAL	材質	Aluminum 鋁
AXLE	軸心	Steel 鐵
WEIGHT	重量	FRONT 前: 50.5g REAR 後: 56.5g



## Q27

MATERIAL	材質	Aluminum 鋁
AXLE	軸心	Steel 鐵
WEIGHT	重量	FRONT 前: 56.4g REAR 後: 61.8g

# HEADSET PACKING



**MFH - 21 ( 1" )**



**MFH-2 ( 1-1/8" )**



**MFH-11(1-1/8" )**



**MFH-12  
( 1-1/2" )**



**MFH-1  
( 1" & 1-1/8" )**

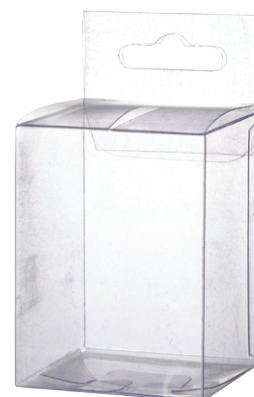

**MFH-3**



**MFH-4**



**MFC-1**



**MFC-2**

**BOTTOM BRACKET PACKING**



**MFB-5**



**MFB-6**



**MFB-3**



**MFB-21**



**MFB-2**



**MFB-1**



**HUBS  
PACKAGING**



**PEDAL  
PACKAGING**



**PEDAL  
PACKAGING**

# NECO

CATALOGUE & TECHNICAL MANUAL

## 2025

## 2026

### 誌慶工業股份有限公司(台灣總部) Neco Technology Industry Co, Ltd (Headquarters)

ADD : No.190, Zhongzheng Rd., Wufeng Dist., Taichung City 41362, Taiwan

TEL : +886-4-2332 3966 FAX: +886-4-2332-2866 EMAIL: neco@necoparts.com

### 廣東志慶精密五金有限公司Guangdong Zhiqing Precision Hardware Parts Co. Ltd

ADD : Unit101, Buliding 9rd, Jilong Zhizao Park, No.52 Xilian Road, Longyan Village, Leliu, Shunde, Foshan, Guangdong, 528300, China

TEL : +86-757-22626559

FAX : +86-757-22626459

EMAIL : sdneco@vip.126.com

### 江蘇誌慶精密五金零件有限公司Jiangsu Zhiqing Precision Hardware Parts Co. Ltd

ADD : Industrial Concentration Zone, Tianwang Town, Jurong City, Jiangsu Province, China

TEL : +86-511-80275988

EMAIL : neco-zj@vip.163.com, necoparts@163.com

### 志慶科技(天津)有限公司Neco Technology(TIANJIN)Co.,LTD

ADD : No.17, 24th Road Jinghai Economic Development Zone, Jinghai Town Tianjin China

TEL : +86-22-59591630

EMAIL : tianjinneco@163.com

### 零貝電機科技(上海)有限公司 Lingbei Motor Technology (SHANGHAI) CO.,Ltd

OFFICE ADD : No.5158 Dongchuan Road, Pudong New Area Shanghai, China

PRODUCTION ADD : Industrial Concentration Zone, Tianwang Town, Jurong City, Jiangsu Province, China

TEL : +86-21-68412951

FAX : +86-21-20428126

EMAIL : necomotorrexchen@lingbeimotor.cn

