

NECO



CATALOGUE & TECHNICAL
MANUAL 2025-2026

<https://www.necoparts.com>

CATALOGUE & TECHNICAL MANUAL 2025-2026



NECO

NECO : NEVER COME OFF PROFESSIONAL BIKE PARTS MANUFACTURERS

Neco Technology Industry Co.Ltd., founded in 1986 in Taichung ,have been in the forefront of machinery tooling design and development. Having acquired more than 30 years of experience in the cycling field ,general manager Mr. Neco Wang has been extensively making contributions to not only the growth ,development and success of the company ,but to the global bicycle industry as well.

In order to offer high quality products and expand plant capacity, we specialize in manufacturing headsets and bottom bracket components. Not only can we cover a wide range of applications and finishes ,but we can also extend the capacities of alloy cold forging ,steel press ,hole tapping and CNC finishing ,etc.

Starting from 2010 ,Neco Ltd. has extended its product categories to include CNC pedals ,hubs and chainwheels, To offer the best service and shortest lead-time ,Neco Ltd. has established 4 factories in China ; one in Shunde City ,Guangdong(since 1997) ,one in Tianwang Town ,JurongCity (since 2001) and also the factory in Tianjin(since 2013).In 2016,Lingbei Motor Technology joined in Neco group, Lingbei Motor Technology(Shanghai)Co.,Ltd. is a company dedicated to the production of electric vehicle components and complete sets of systems, its products are exported to international, specializing in the motor system for electric bicycles pedal bicycles and, scooters its products are on sale in china, European and the American markets.

After constant improvement and efficient management ,every Neco factory is well established and play an important role in the Neco group.

Taiwan factory continuously focuses on high-end products and expanding design capabilities with our state-of-the-art research facility. However ,we believe the entire range of market demands from economic models to technologically cold forged CNC component.Meanwhile ,Neco Ltd. will always strive to meet the commitments to all of the customers and provide competitive and high-value products.



2025-2026 CATALOGUE & TECHNICAL MANUAL

HEADSETS 車頭碗組

Cable Routing Headsets	內走線車頭碗組	P.02 - P.04
Integrated Threaded Headsets	全隱藏式無牙車頭碗	P.06 - P.11
Semi-Integrated Threadless Headsets	半隱藏式無牙車頭碗	P.11 - P.20
Semi-Integrated Threaded Headsets	半隱藏式有牙車頭碗	P.21 - P.24
External Cup Threadless Headsets	外露式無牙車頭碗	P.24 - P.30
130° Safety Headsets	安全車頭碗	P.31 - P.34
External Cup Threaded Headsets	外露式有牙車頭碗	P.34 - P.39
E-bike Head Parts	電動車車頭碗組	P.40

ACCESSORIES 配件

Accessories	配件	P.42 - P.46
-------------	----	-------------

BOTTOM BRACKETS B.B 五通碗組

Cartridge Cotterless B.B. Sets	P.48 - P.56
Cartridge ISIS B.B. Sets	P.57 - P.59
External Cup/ Press-Fit B.B. Sets/Bottom Brackets	P.60 - P.68

PEDALS 腳踏

Clipless/CNC Pedals/BMX/City/Mountain/Road/Children 卡踏/鋁合金腳踏/表演車用/城市車用/登山車用/跑車用/童車用	P.70 - P.76
--	-------------

HUBS 花鼓

Road/Mountain Bikes	跑車用/登山車用	P.78 - P.84
Quick Release	快拆	P.85

PACKAGING 補修包裝

Packaging	補修包裝	P.86 - P.87
-----------	------	-------------

CABLE ROUTING HEADSETS

內走線車頭碗組



NECCO

H322TP-1



WEIGHT

104.1g

SIZE

1.5" Head Tube
Reduced To 1-1/8"
Fork Tube Integrated
Threadless Headset

SHIS NORM

IS52.2/28.6
IS52.2/39.8(30)

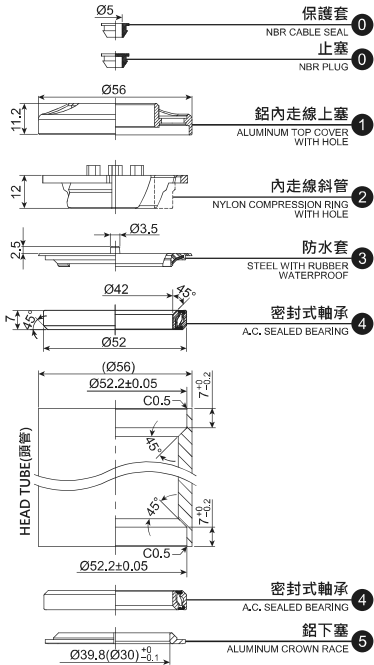

堆積高度 (STACK HEIGHT) = 10.1 ± 1mm

H322MP-1WR



WEIGHT

91.7g

SIZE

1.5" Head Tube
Reduced To 1-1/8"
Fork Tube Integrated
Threadless Headset

SHIS NORM

IS52.2/28.6
IS52.2/39.8(30)

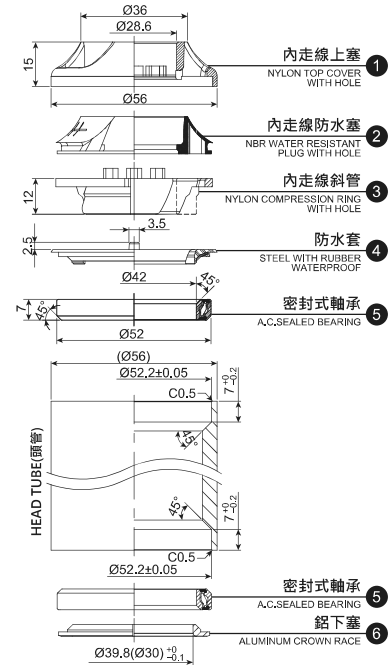

堆積高度 (STACK HEIGHT) = 16.8 ± 1 mm

H324



WEIGHT

91.1g

SIZE

1.5" Head Tube
Reduced To 1-1/8"
Fork Tube Integrated
Threadless Headset

SHIS NORM

IS52.2/28.6
IS52.2/39.8(30)

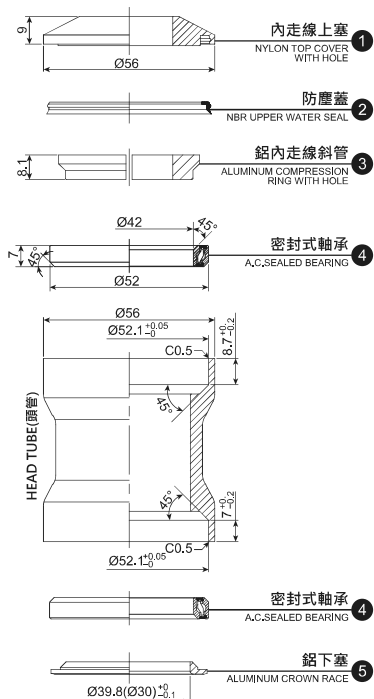

堆積高度 (STACK HEIGHT) = 10.6 ± 1 mm

H326MP



WEIGHT

101.3g

SIZE

1.5" Head Tube
Reduced To 1-1/8"
Fork Tube Integrated
Threadless Headset

SHIS NORM

IS52.2/28.6
IS52.2/39.8(30)

Available For Zoom
Stem Model

TW-AL-408

Available For UUR
Stem Model

HB-400B

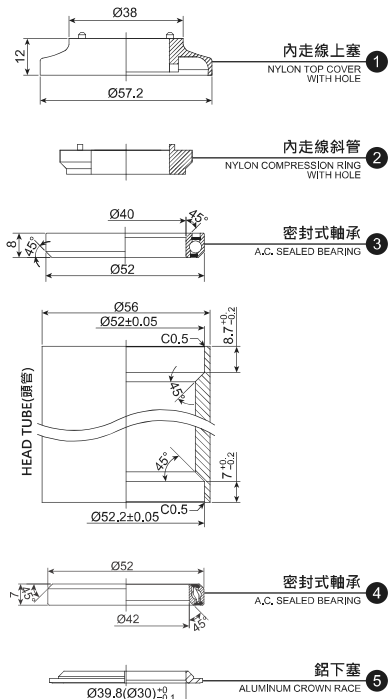

堆積高度 (STACK HEIGHT) = 13.4 ± 1 mm

H329A



WEIGHT
115.8g

SIZE

1.5" Head Tube
Reduced To 1-1/8" Fork
Tube Integrated
Threadless Headset

SHIS NORM
IS52.2/28.6
IS52.2/39.8(30)

Available For
Zoom Stem Model

TDS-(R)D631-8FOV/
TDS-D632-8FOV/
TDS-D634-8FOV/
TDS-636-8FOV
TDS-645(SERIES)
-8FOV/TDS-658-8FOV/
TM-AL-20-8

OPTIONAL

H329MP:
NYLON TOP COVER

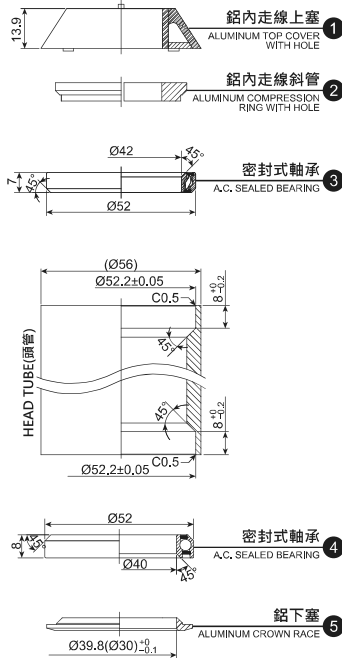

堆積高度 (STACK HEIGHT) = 15.5±1mm

H331



WEIGHT
73.7g

SIZE

1.5" Head Tube
Reduced To 1-1/8" Fork
Tube Integrated
Threadless Headset

SHIS NORM
IS52.2/28.6
IS52.2/39.8(30)

Available For Zoom Model

TDS-(R)D631-8FOV/
TDS-D632-8FOV/
TDS-D634-8FOV/
TDS-636-8FOV
TDS-645(SERIES)
-8FOV/TDS-658-8FOV/
TM-AL-20-8

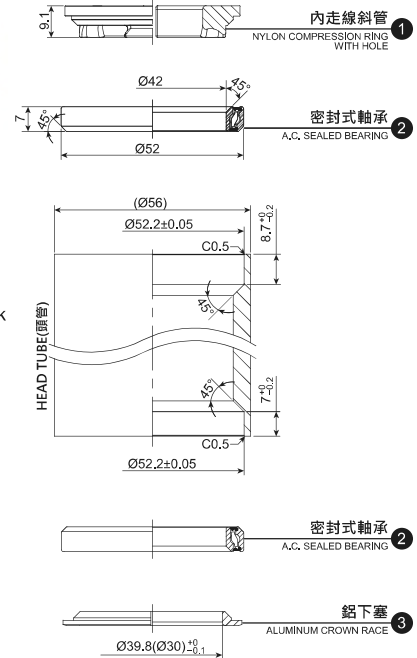

堆積高度 (STACK HEIGHT) = 1.8±0.5 mm

H156ECR



WEIGHT
194.7g

SIZE

1.5" Head Tube
Reduced To 1-1/8"
Fork Tube
Semi-Integrated
Threadless Headset

SHIS NORM
ZS56/28.6
ZS56/39.8(30)

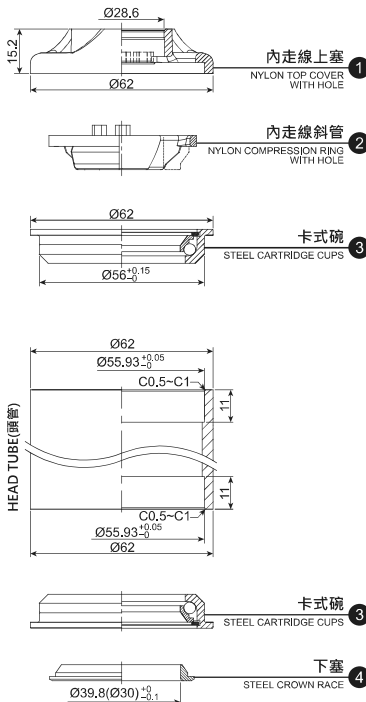

堆積高度 (STACK HEIGHT) = 20.6 ± 1 mm

H323MP-2WR



WEIGHT
118g

SIZE

1.5" Head Tube
Reduced To 1-1/8" Fork
Tube Semi-Integrated
Threadless Headset

SHIS NORM
ZS56/28.6
ZS56/39.8(30)

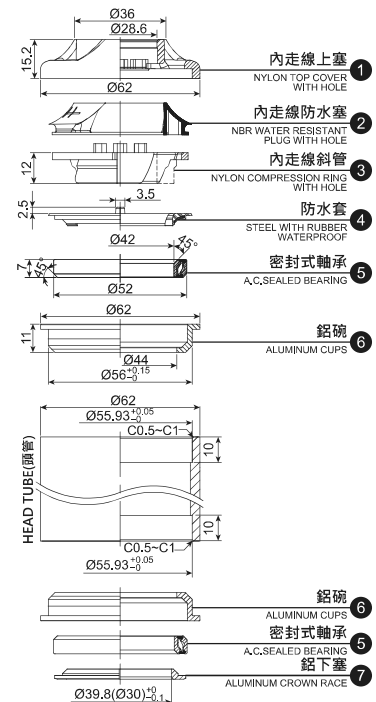

堆積高度 (STACK HEIGHT) = 21.1 ± 1 mm

H325MP



WEIGHT

119.5g

SIZE

1.5" Head Tube
Reduced To 1-1/8" Fork
Tube Semi-Integrated
Threadless Headset

SHIS NORM

ZS56/28.6
ZS56/39.8(30)

Available For
Bigstone Model

M300C

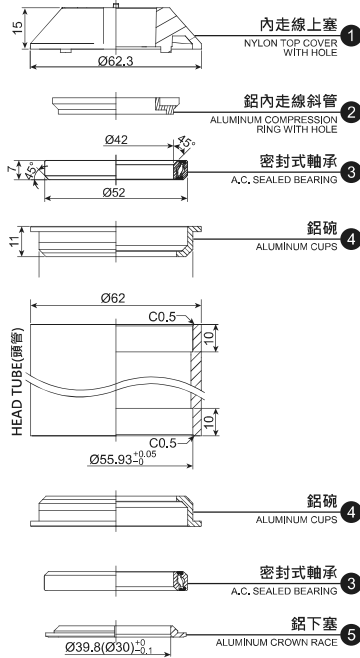

堆積高度 (STACK HEIGHT) = 20.3±1mm

H330A



WEIGHT

176.9g

SIZE

1.5" Head Tube
Reduced To 1-1/8" Fork
Tube Semi-Integrated
Threadless Headset

SHIS NORM

ZS56/28.6
ZS56/39.8(30)

Available For Zoom Model

TDS-(R)D631-8FOV/
TDS-D632-8FOV/
TDS-D634-8FOV/
TDS-636-8FOV
TDS-645(SERIES)-
8FOV/TDS-658-8FOV/
TM-AL-20-8

OPTIONAL

H330MP:
NYLON TOP COVER

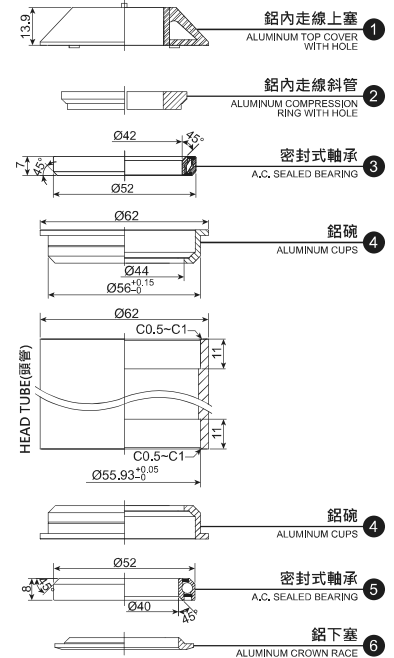

堆積高度 (STACK HEIGHT) = 19.5±1 mm

H334

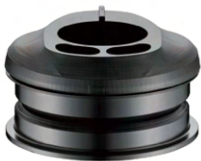

WEIGHT

117.4g

SIZE

1.5" Head Tube
Reduced To 1-1/8" Fork
Tube Semi-Integrated
Threadless Headset

SHIS NORM

ZS56/28.6
ZS56/39.8(30)

Available For Zoom Model

TDS-(R)D631-8FOV/
TDS-D632-8FOV/
TDS-D634-8FOV/
TDS-636-8FOV
TDS-645(SERIES)-
8FOV/TDS-658-8FOV/
TM-AL-20-8

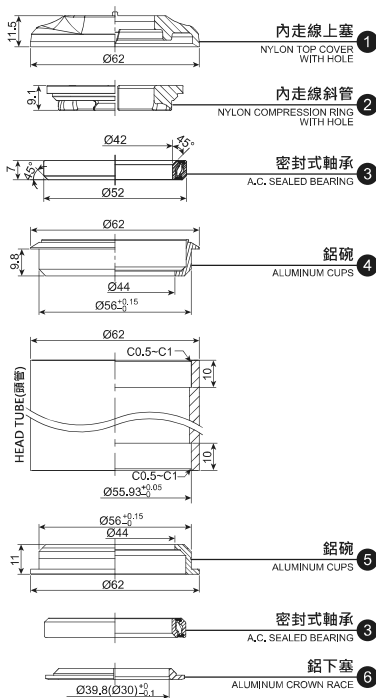

堆積高度 (STACK HEIGHT) = 15.4 ± 1 mm

H335



WEIGHT

133g

SIZE

1.5" Head Tube
Reduced To 1-1/8" Fork
Tube Semi-Integrated
Threadless Headset

SHIS NORM

ZS56/28.6
ZS56/39.8(30)

Available For
CHUHN-E Model

AS-E08

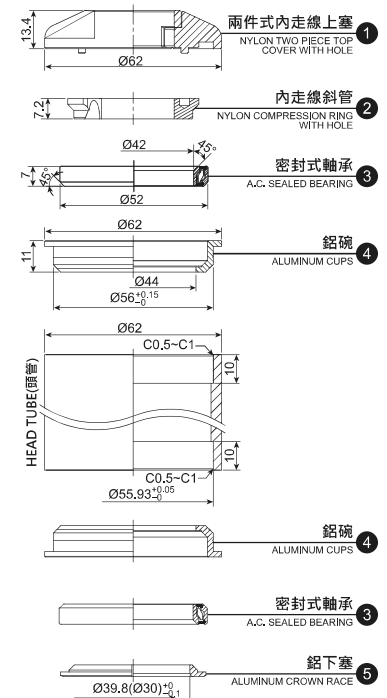

堆積高度 (STACK HEIGHT) = 18.9 ± 1 mm

HEADSETS

車頭碗組



NECO

H02



WEIGHT

50g

SIZE

1" Integrated Threadless Headset

SHIS NORM

IS38.2/25.4
IS38.2/27(26.4)

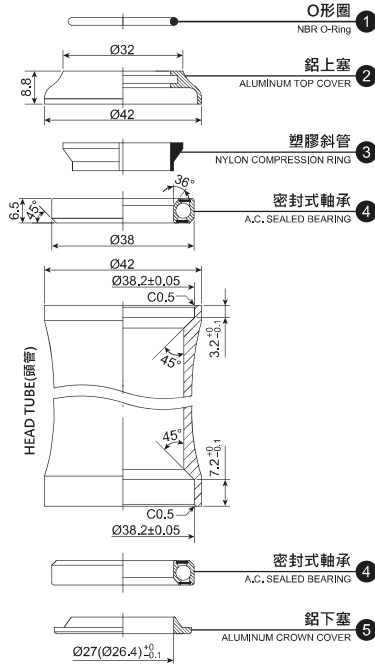

堆積高度 (STACK HEIGHT) = $10.5 \pm 1\text{mm}$

H22



WEIGHT

55g

SIZE

1-1/8" Integrated Threadless Headset

SHIS NORM

IS41.2/28.6
IS41.2/30

可選配之上塞高度 (TOP COVER IS OPTIONAL)

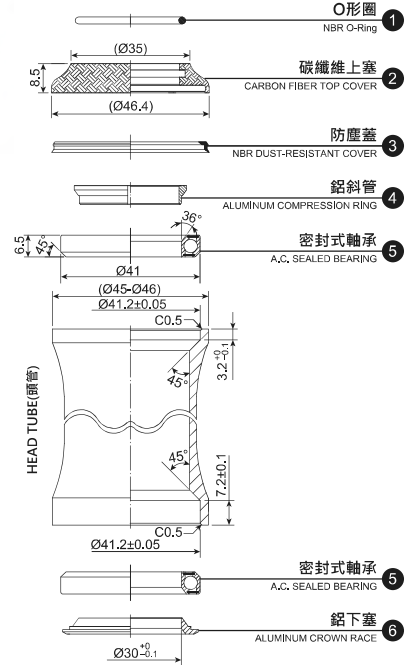
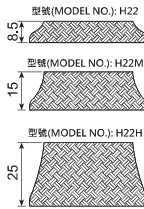

堆積高度 (STACK HEIGHT) = $10.2 \pm 1\text{mm}$

H23



WEIGHT

60.3g

SIZE

1-1/8" Integrated Threadless Headset

SHIS NORM

IS41.2/28.6
IS41.2/30

可選配之上塞高度 (TOP COVER IS OPTIONAL)

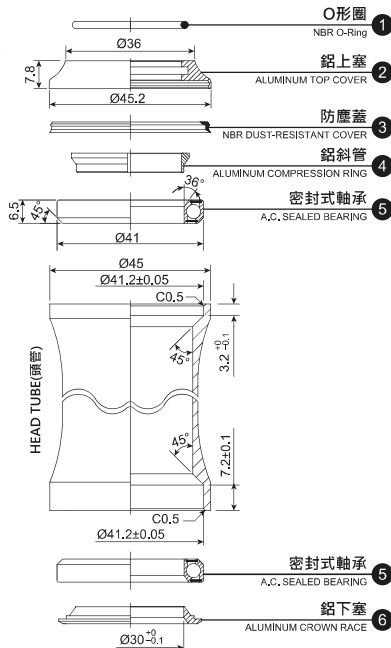
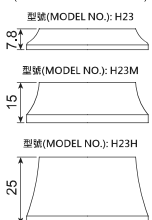

堆積高度 (STACK HEIGHT) = $9.5 \pm 1\text{mm}$

H27



WEIGHT

61g

SIZE

1-1/8" Integrated Threadless Headset
Campy Compatible

SHIS NORM

IS42/28.6
IS42/30

可選配之上塞高度 (TOP COVER IS OPTIONAL)

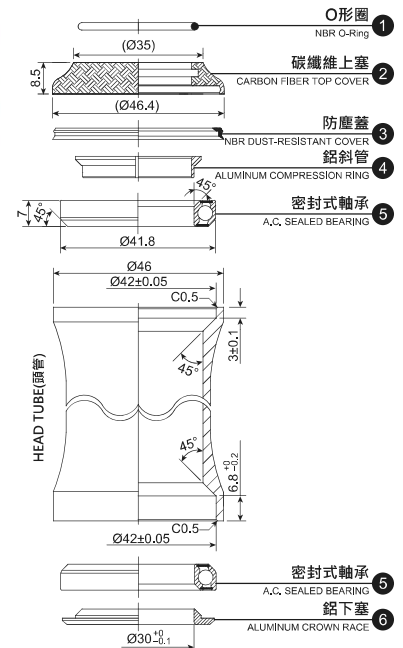
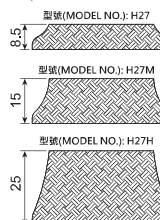

堆積高度 (STACK HEIGHT) = $10.1 \pm 1\text{mm}$

NECO INTEGRATED THREADLESS HEADSETS

全隱藏式無牙車頭碗 INTEGRATED THREADLESS HEADSETS

H50



WEIGHT

64g

SIZE

1-1/8" Integrated Threadless Headset

SHIS NORM

IS41.2/28.6
IS41.2/30

可選配之上塞高度 (TOP COVER IS OPTIONAL)

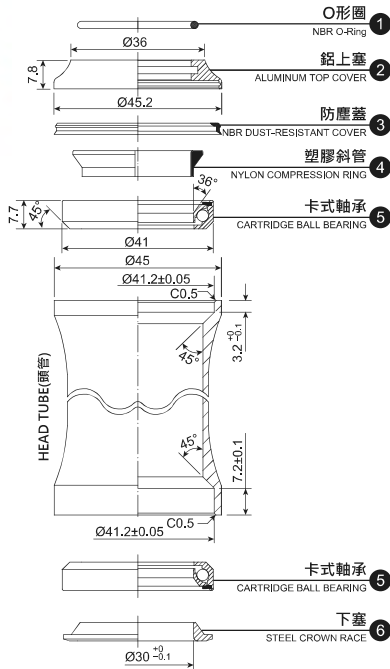
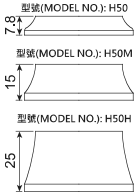

堆積高度 (STACK HEIGHT) = 9.8 ± 1 mm

H51



WEIGHT

65g

SIZE

1-1/8" Integrated Threadless Headset Campy Compatible

SHIS NORM

IS42/28.6
IS42/30

可選配之上塞高度 (TOP COVER IS OPTIONAL)

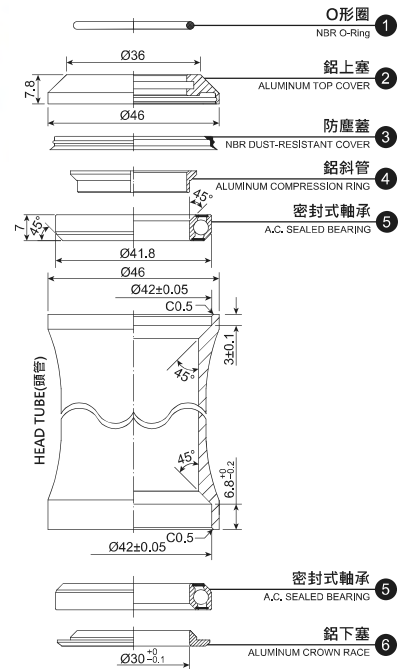
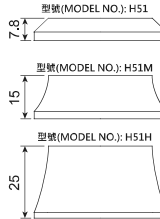

堆積高度 (STACK HEIGHT) = 9.4 ± 1 mm

H51S



WEIGHT

70g

SIZE

1-1/8" Head Tube Reduced to 1" Fork Stem Integrated Threadless Headset

SHIS NORM

IS42/25.4
IS42/27(26.4)

可選配之上塞高度 (TOP COVER IS OPTIONAL)

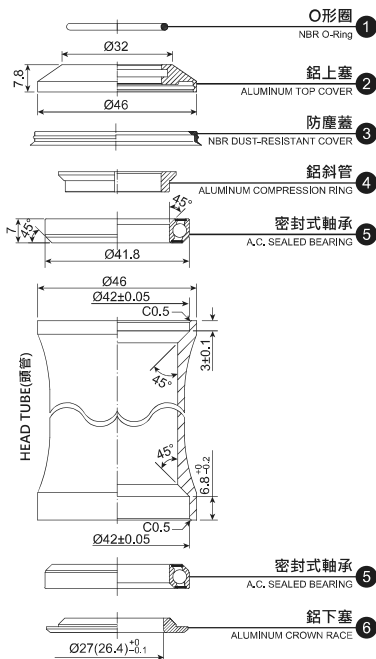
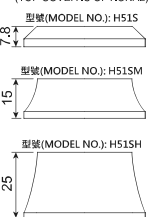

堆積高度 (STACK HEIGHT) = 9.4 ± 1 mm

H52



WEIGHT

74g

SIZE

1-1/8" Integrated Threadless Headset Campy Compatible

SHIS NORM

IS42/28.6
IS42/30

可選配之上塞高度 (TOP COVER IS OPTIONAL)

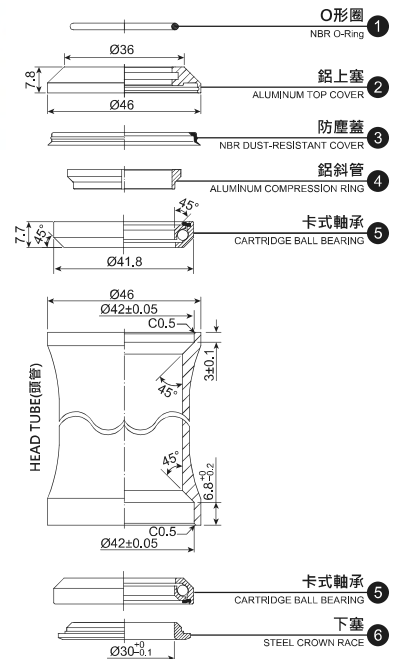
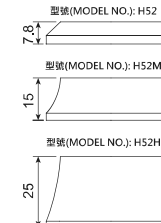

堆積高度 (STACK HEIGHT) = 9.4 ± 1 mm

H52MP

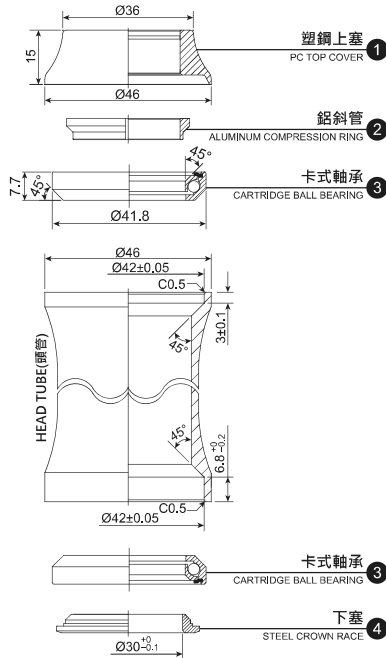

WEIGHT

70g

SIZE

1-1/8" Integrated Threadless Headset Campy Compatible

SHIS NORM

IS42/28.6
IS42/30

H160

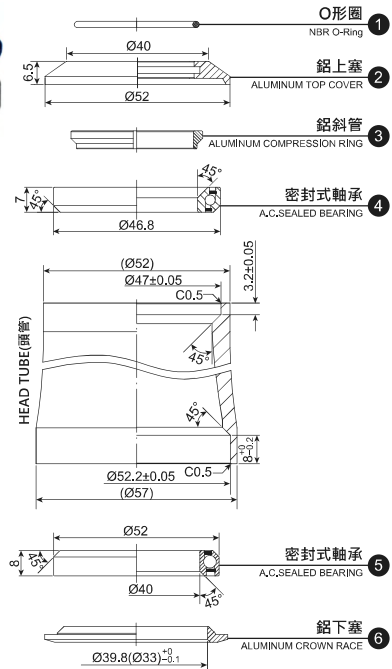

WEIGHT

85g

SIZE

1.5" Head Tube Reduced to 1-1/4" Fork Tube Integrated Threadless Headset

SHIS NORM

IS47/31.8
IS52.2/39.8(33)

H373 [H373C]

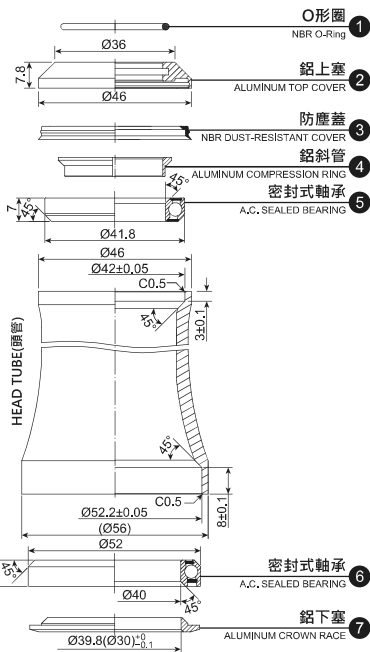

WEIGHT

80g

SIZE

1.5" Head Tube Reduced to 1-1/8" Fork Tube Integrated Threadless Headset

SHIS NORM

IS42/28.6
IS52.2/39.8(30)

OPTIONAL

H373C-Carbon Top Cover Stack Height 10.4 ± 1mm

可選配之上塞高度 (TOP COVER IS OPTIONAL)

型號 (MODEL NO.): H373

型號 (MODEL NO.): H373M

型號 (MODEL NO.): H373H

型號 (MODEL NO.): H373H

H373S

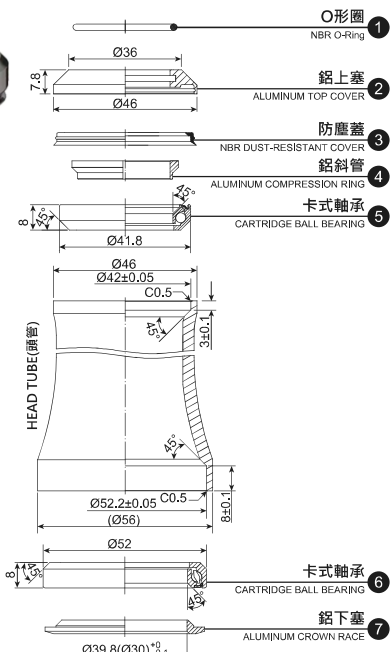

WEIGHT

83.6g

SIZE

1.5" Head Tube Reduced to 1-1/8" Fork Tube Integrated Threadless Headset

SHIS NORM

IS42/28.6
IS52.2/39.8(30)

可選配之上塞高度 (TOP COVER IS OPTIONAL)

型號 (MODEL NO.): H373S

型號 (MODEL NO.): H373SM

型號 (MODEL NO.): H373SH

H373MPS



WEIGHT

88g

SIZE

1.5" Head Tube
Reduced to 1-1/8"
Fork Tube Integrated
Threadless Headset

SHIS NORM

IS42/28.6
IS52.2/39.8 (30)

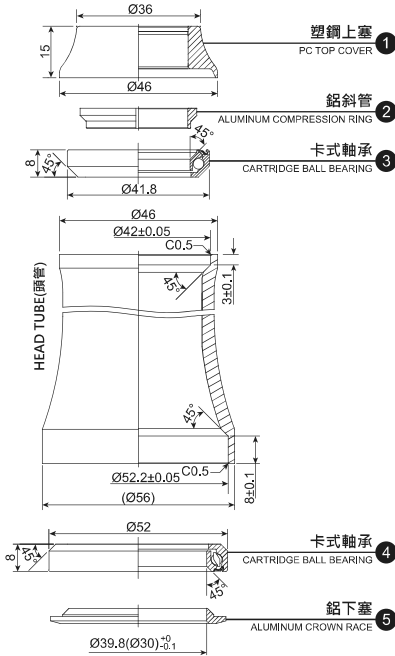

堆積高度 (STACK HEIGHT) = 16.3 ± 1 mm

H373-B52



WEIGHT

80g

SIZE

1.5" Head Tube
Reduced to 1-1/8"
Fork Tube Integrated
Threadless Headset

SHIS NORM

IS42/28.6
IS52/39.8(30)

可選配之上塞高度
(TOP COVER IS OPTIONAL)
型號(MODEL NO.): H373-B52

型號(MODEL NO.): H373M-B52

型號(MODEL NO.): H373H-B52

型號(MODEL NO.): H373M-B52

型號(MODEL NO.): H373H-B52

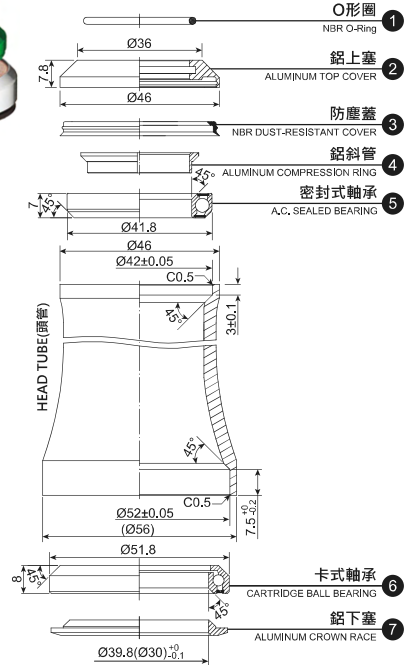

堆積高度 (STACK HEIGHT) = 9.5 ± 1 mm

H373FT-B52



WEIGHT

75g

SIZE

1.5" Head Tube
Reduced to 1-1/8"
Fork Tube Integrated
Threadless Headset

SHIS NORM

IS42/28.6
IS52/39.8(30)

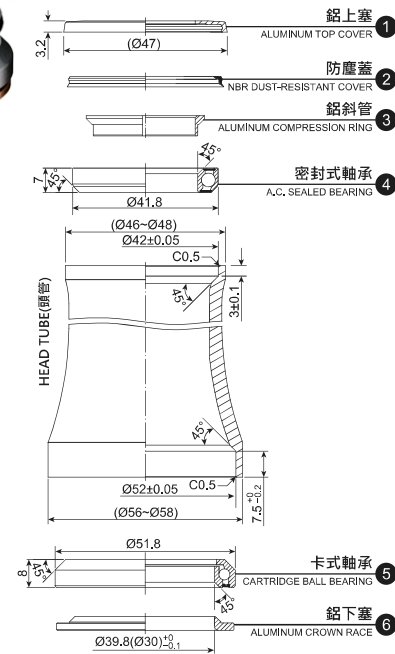

堆積高度 (STACK HEIGHT) = 4.5 ± 1 mm

H373G



WEIGHT

87g

SIZE

1.5" Head Tube
Reduced to 1-1/8"
Fork Tube Integrated
Threadless Headset

SHIS NORM

IS42/28.6
IS52.2/39.8(30)

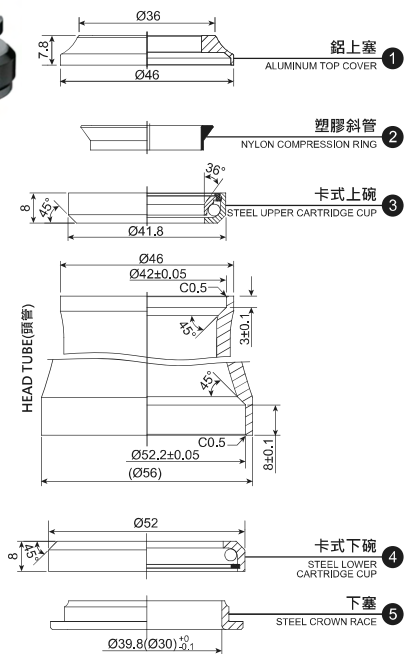

堆積高度 (STACK HEIGHT) = 9.1 ± 1 mm

H373GMP

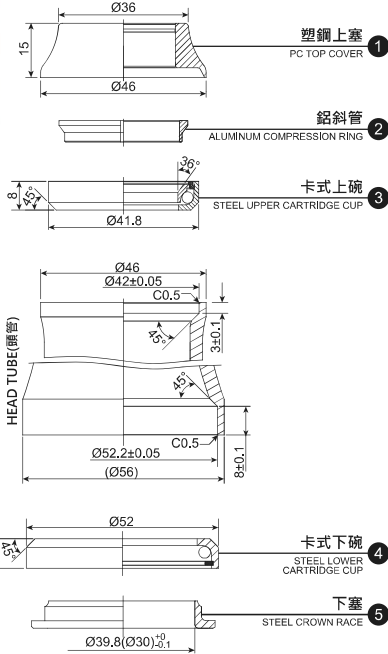

WEIGHT

88g

SIZE

1.5" Head Tube
Reduced to 1-1/8"
Fork Tube Integrated
Threadless Headset

SHIS NORM

IS42/28.6
IS52.2/39.8(30)

H382 [1.5"]

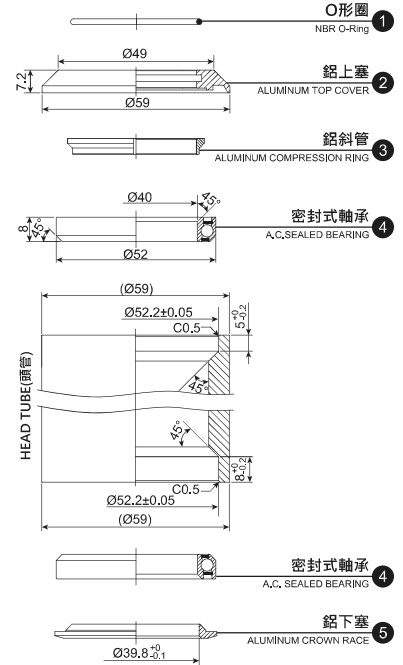

WEIGHT

99g

SIZE

1.5" Integrated
Threadless Headset

SHIS NORM

IS52.2/38.1
IS52.2/39.8

H382S

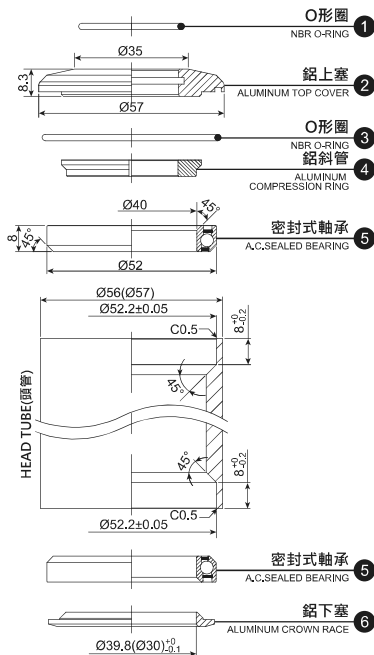

WEIGHT

113.3g

SIZE

1.5" Head Tube
Reduced to 1-1/8"
Fork Tube Integrated
Threadless Headset

SHIS NORM

IS52.2/28.6
IS52.2/39.8(30)

可選配之上塞高度
(TOP COVER IS OPTIONAL)
型號(MODEL NO.): H382SM

H397

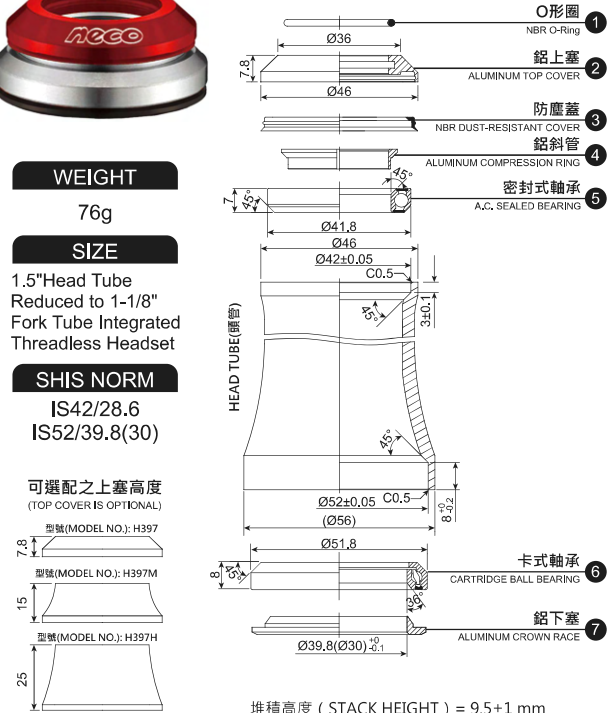

WEIGHT

76g

SIZE

1.5" Head Tube
Reduced to 1-1/8"
Fork Tube Integrated
Threadless Headset

SHIS NORM

IS42/28.6
IS52/39.8(30)

可選配之上塞高度
(TOP COVER IS OPTIONAL)

型號(MODEL NO.): H397

型號(MODEL NO.): H397M

型號(MODEL NO.): H397H

全隱藏式無牙車頭碗 INTEGRATED THREADLESS HEADSETS
半隱藏式無牙車頭碗 SEMI-INTEGRATED THREADLESS HEADSETS

H398



WEIGHT

76g

SIZE

1-1/4" Head Tube
Reduced to 1-1/8"
Fork Tube Integrated
Threadless Headset

SHIS NORM

IS42/28.6
IS47.2/33(30)

可選配之上塞高度
(TOP COVER IS OPTIONAL)

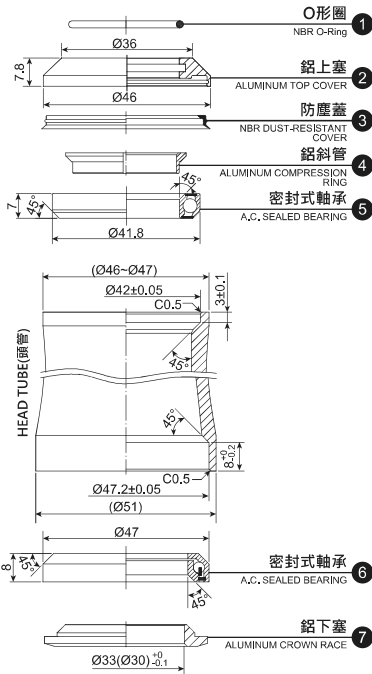
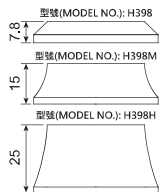

堆積高度 (STACK HEIGHT) = 9.7 ± 1 mm



H100



WEIGHT

123g

SIZE

1-1/4" Head Tube
Reduced to 1-1/8"
Fork Tube
Semi-Integrated
Threadless Headset

SHIS NORM

ZS44/28.6
ZS50.6/33(30)

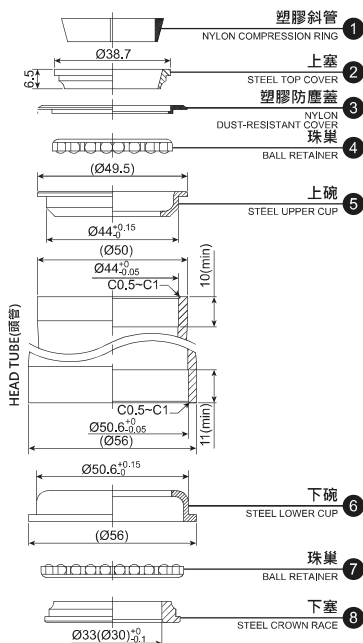

堆積高度 (STACK HEIGHT) = 8.7 ± 1 mm

H100M-1 [H100H-1]



WEIGHT

149g

SIZE

1-1/4" Head Tube
Reduced to 1-1/8"
Fork Tube
Semi-Integrated
Threadless Headset

SHIS NORM

ZS44/28.6
ZS50.6/33(30)

可選配之上塞高度
(TOP COVER IS OPTIONAL)

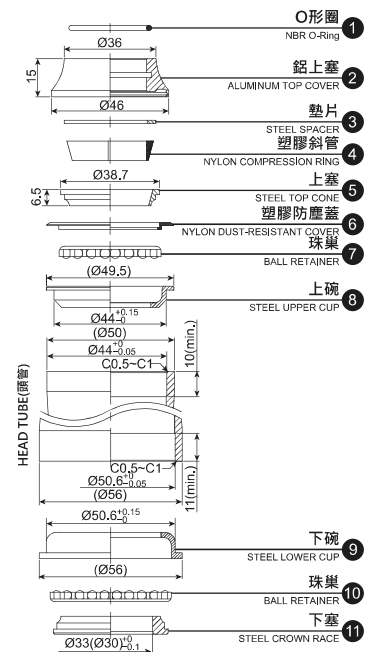
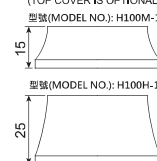

堆積高度 (STACK HEIGHT) = 22.5 ± 1 mm

H114



WEIGHT

105g

SIZE

1-1/8"
Semi-Integrated
Threadless Headset

SHIS NORM

ZS44/28.6
ZS44/30

可選配之上塞高度
(TOP COVER IS OPTIONAL)

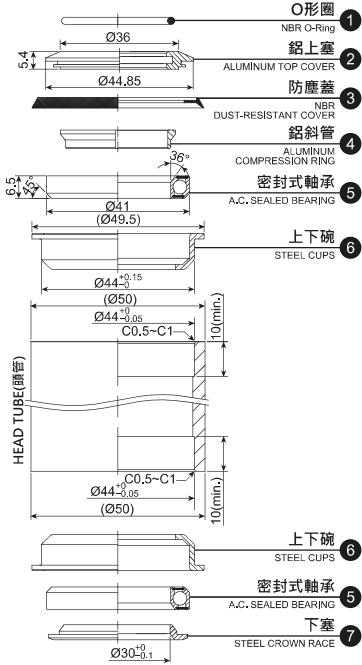
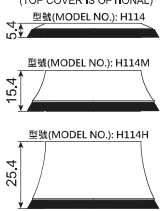

堆積高度 (STACK HEIGHT) = 9.9 ± 1 mm

H115



WEIGHT

97g

SIZE

1-1/8"
Semi-Integrated
Threadless Headset

SHIS NORM

ZS44/28.6
ZS44/30

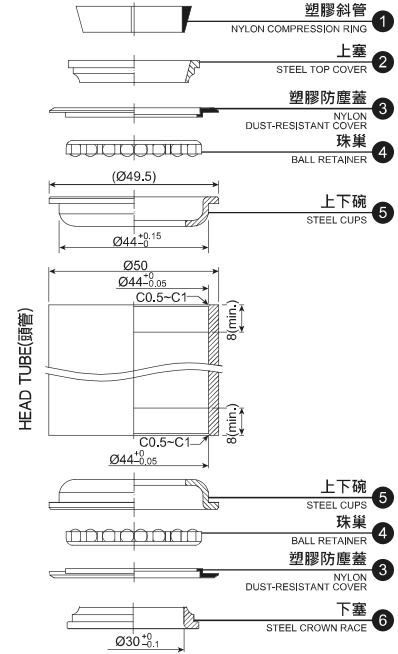

堆積高度 (STACK HEIGHT) = 9.8 ± 1 mm

H115MP



WEIGHT

113g

SIZE

1-1/8"
Semi-Integrated
Threadless Headset

SHIS NORM

ZS44/28.6
ZS44/30

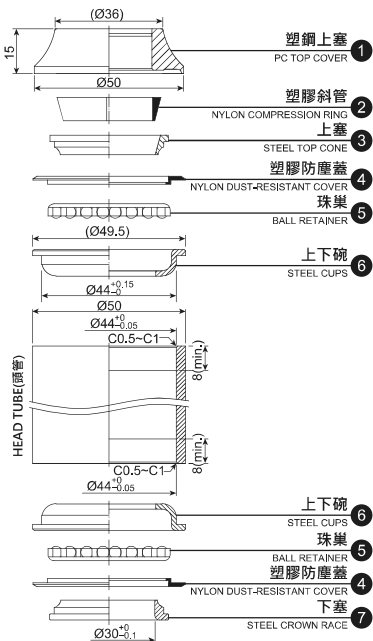

堆積高度 (STACK HEIGHT) = 23.6 ± 1 mm

H115M-1 [H115H-1]



WEIGHT

H115M-1:121g
H115H-1:138g

SIZE

1-1/8"
Semi-Integrated
Threadless Headset

SHIS NORM

ZS44/28.6
ZS44/30

可選配之上塞高度
(TOP COVER IS OPTIONAL)

型號(MODEL NO.): H115M-1

型號(MODEL NO.): H115H-1

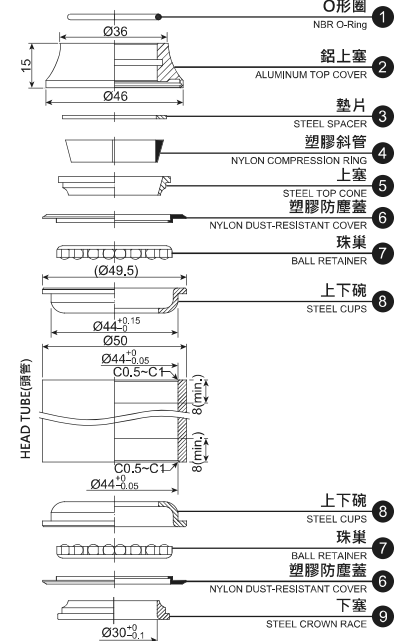
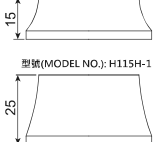

堆積高度 (STACK HEIGHT) = 23.2 ± 1 mm

NECO SEMI-INTEGRATED THREADLESS HEADSETS

半隱藏式無牙車頭碗 SEMI-INTEGRATED THREADLESS HEADSETS

H117DM



WEIGHT

106g

SIZE

1-1/8"
Semi-integrated
Threadless Headset

SHIS NORM

ZS44/28.6
ZS44/30

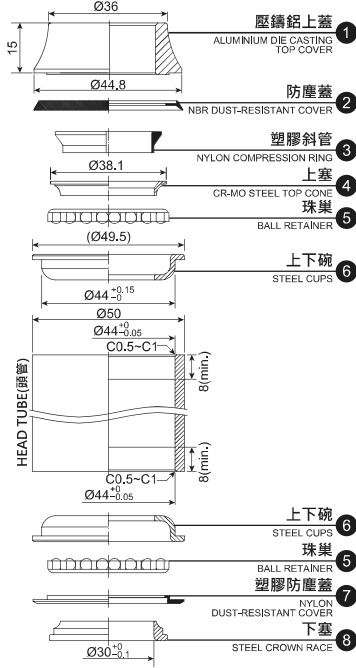

堆積高度 (STACK HEIGHT) = 23 ± 1 mm

H117SM



WEIGHT

99g

SIZE

1-1/8"
Semi-Integrated
Threadless Headset

SHIS NORM

ZS44/28.6
ZS44/30

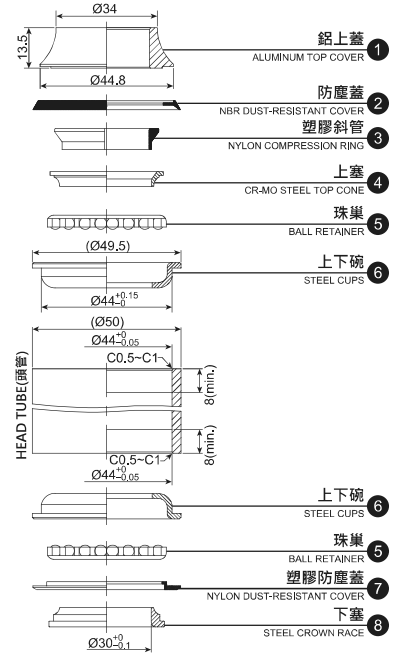

堆積高度 (STACK HEIGHT) = 21.2 ± 1 mm

H119CDM



WEIGHT

141.3g

SIZE

1-1/8"
Semi-Integrated
Threadless Headset

SHIS NORM

ZS44/28.6
ZS44/30

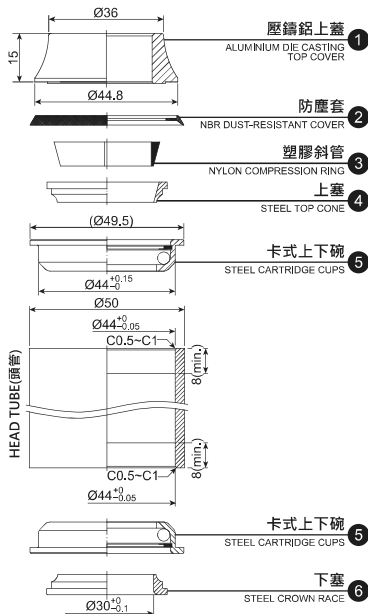

堆積高度 (STACK HEIGHT) = 21.2 ± 1 mm

H119MP-1



WEIGHT

96g

SIZE

1-1/8"
Semi-integrated
Threadless Headset

SHIS NORM

ZS44/28.6
ZS44/30

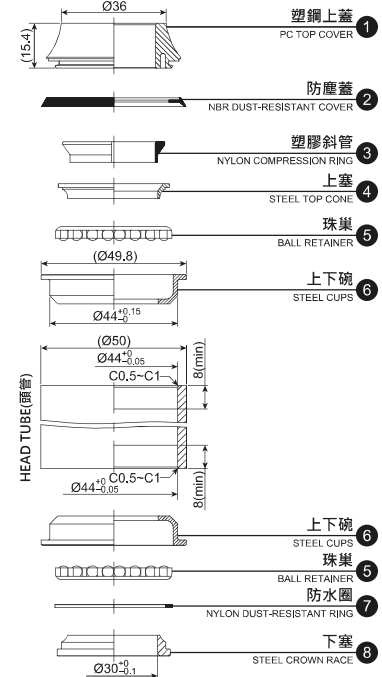

堆積高度 (STACK HEIGHT) = 19.2 ± 1 mm

H124



WEIGHT

91g

SIZE

1" Semi-Integrated
Threadless Headset

SHIS NORM

ZS44/25.4
ZS44/27(26.4)

可選配之上塞高度
(TOP COVER IS OPTIONAL)

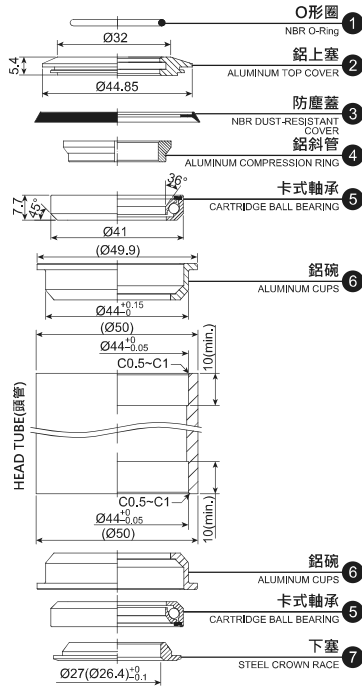
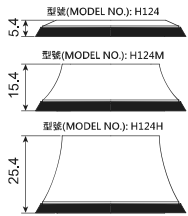

H125



WEIGHT

60.8g

SIZE

1-1/8" Semi-Integrated
Threadless Headset

SHIS NORM

ZS44/28.6
ZS44/30

可選配之上塞高度
(TOP COVER IS OPTIONAL)

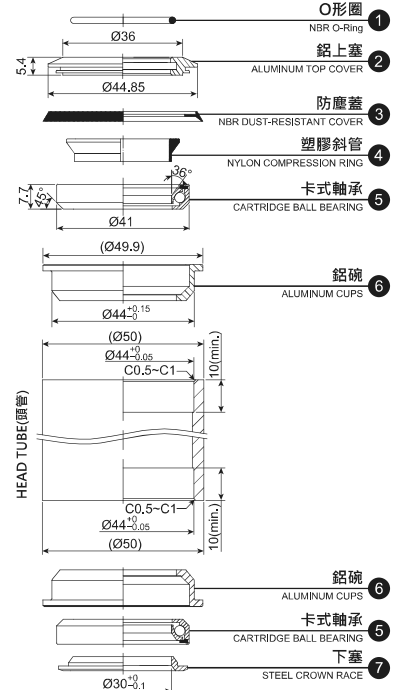
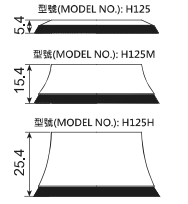

H145



WEIGHT

77g

SIZE

1-1/8" Semi-Integrated
Threadless Headset

SHIS NORM

ZS44/28.6
ZS44/30

可選配之上塞高度
(TOP COVER IS OPTIONAL)

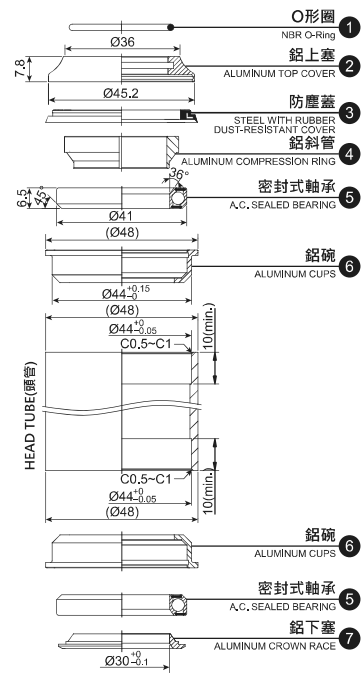
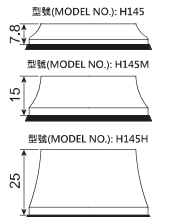

H146



WEIGHT

77.8g

SIZE

1-1/8" Semi-Integrated
Threadless Headset

SHIS NORM

ZS44/28.6
ZS44/30

可選配之上塞高度
(TOP COVER IS OPTIONAL)

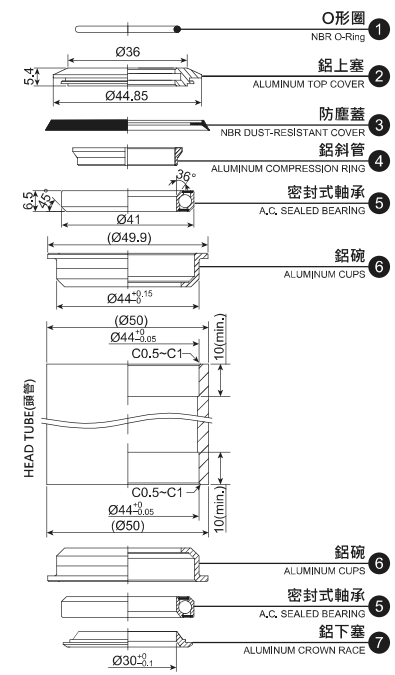
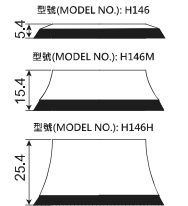

NECO SEMI-INTEGRATED THREADLESS HEADSETS

半隱藏式無牙車頭碗 SEMI-INTEGRATED THREADLESS HEADSETS

H148

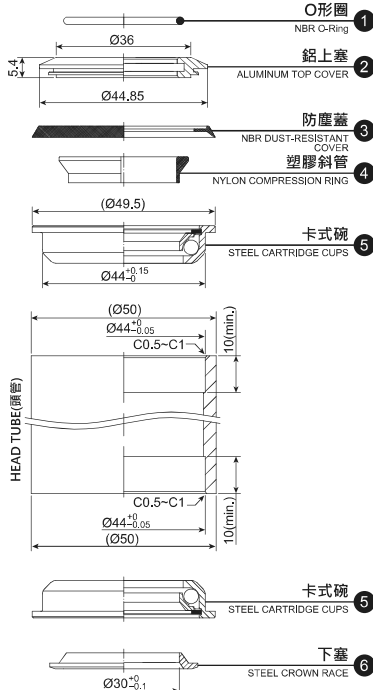

堆積高度 (STACK HEIGHT) = 9.9 ± 1 mm

WEIGHT

106g

SIZE

1-1/8"
Semi-Integrated
Threadless Headset

SHIS NORM

ZS44/28.6
ZS44/30

可選配之上塞高度
(TOP COVER IS OPTIONAL)

型號 (MODEL NO.): H148

5.4

型號 (MODEL NO.): H148M

15.4

型號 (MODEL NO.): H148H

25.4

H148MP

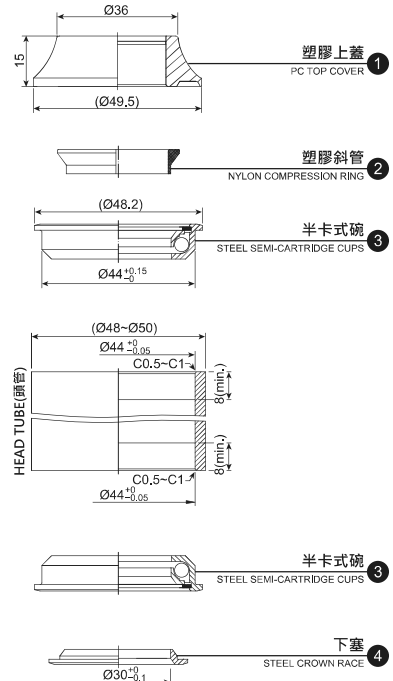

堆積高度 (STACK HEIGHT) = 19.5 ± 1 mm

WEIGHT

103.3g

SIZE

1-1/8"
Semi-Integrated
Threadless Headset

SHIS NORM

ZS44/28.6
ZS44/30

H148MP-1

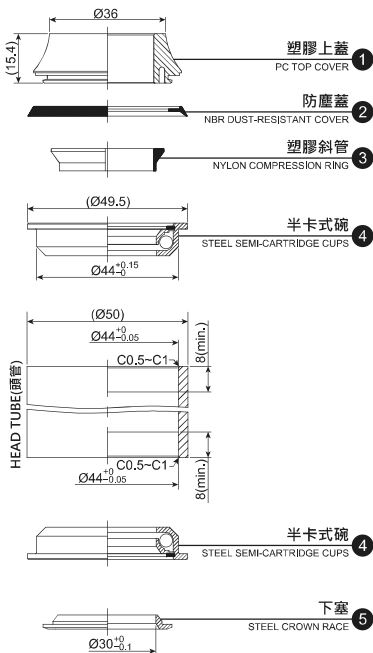

堆積高度 (STACK HEIGHT) = 19.5 ± 1 mm

WEIGHT

107.7g

SIZE

1-1/8"
Semi-Integrated
Threadless Headset

SHIS NORM

ZS44/28.6
ZS44/30

H148DM

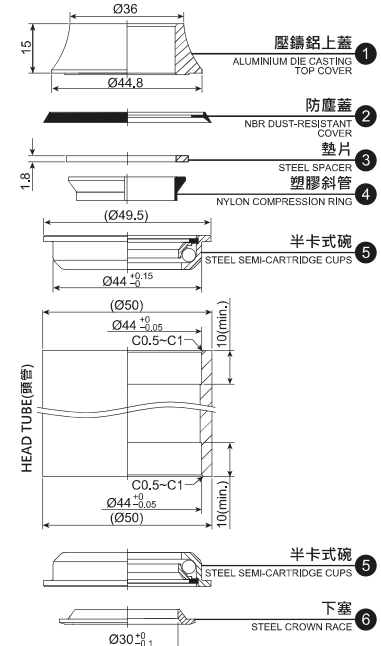

堆積高度 (STACK HEIGHT) = 21.6 ± 1 mm

WEIGHT

122.8g

SIZE

1-1/8"
Semi-Integrated
Threadless Headset

SHIS NORM

ZS44/28.6
ZS44/30

H151S



WEIGHT

119g

SIZE

Fits 1-1/8" to 1.5"
Tapered Fork
Threadless Headset

SHIS NORM

ZS44/28.6
EC44/39.8(30)

可選配之上塞高度
(TOP COVER IS OPTIONAL)

型號(MODEL NO.): H151S

型號(MODEL NO.): H151SM

型號(MODEL NO.): H151SH

型號(MODEL NO.): H151SH

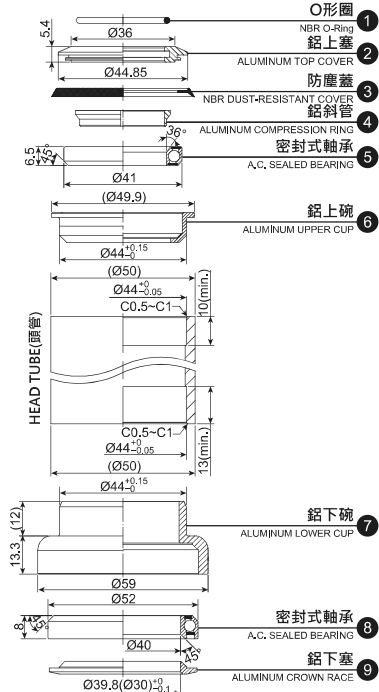

H153-1 [H153E-1]



WEIGHT

135g

SIZE

1.5" Head Tube
Reduced to 1-1/8"
Fork Tube
Semi-Integrated
Threadless headset

SHIS NORM

ZS55(56)/28.6
ZS55(56)/39.8(30)

可選配之上塞高度
(TOP COVER IS OPTIONAL)

型號(MODEL NO.): H153M-1(H153ME-1)

型號(MODEL NO.): H153H-1(H153HE-1)

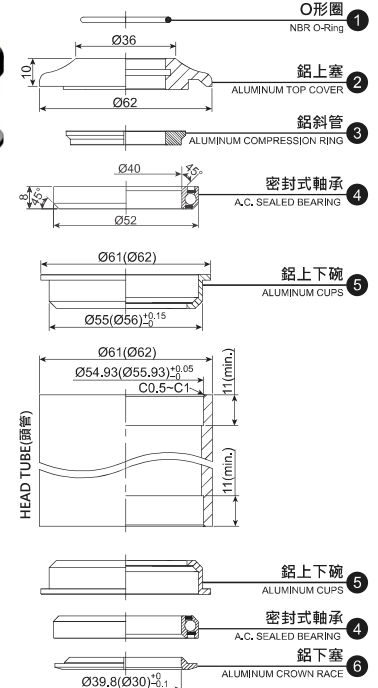

H153E-1-001



WEIGHT

197.3g

SIZE

1.5" Head Tube
Reduced to 1-1/8"
Fork Tube Integrated
Threadless Headset

SHIS NORM

ZS56/28.6
ZS66/45.8(39.8)

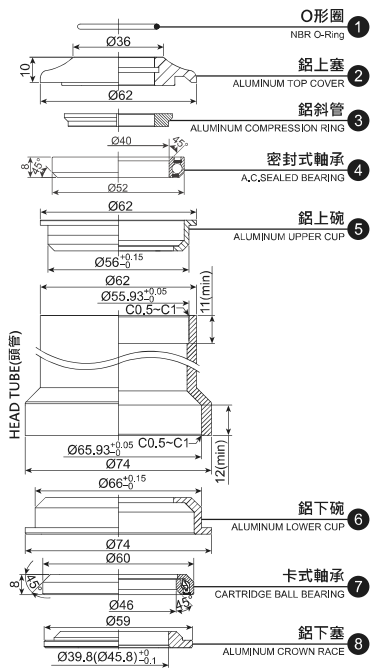

H153-1C [H153E-1C]



WEIGHT

145g

SIZE

1.5" Head Tube
Reduced to 1-1/8"
Fork Tube
Semi-Integrated
Threadless headset

SHIS NORM

ZS55(56)/28.6
ZS55(56)/39.8(30)

可選配之上塞高度
(TOP COVER IS OPTIONAL)

型號(MODEL NO.): H153M-1C(H153ME-1C)

型號(MODEL NO.): H153H-1C(H153HE-1C)

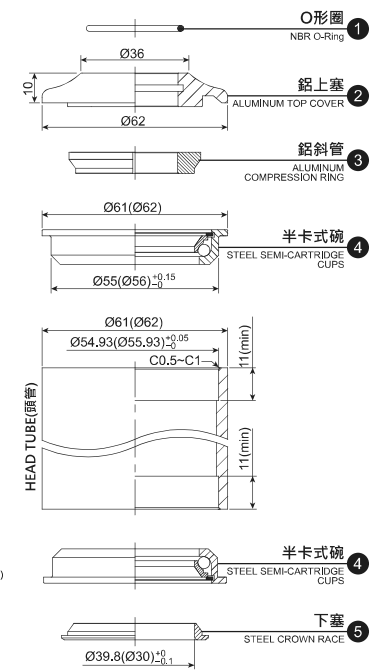

NECO SEMI-INTEGRATED THREADLESS HEADSETS

半隱藏式無牙車頭碗 SEMI-INTEGRATED THREADLESS HEADSETS

H156 [H156E]



WEIGHT

134g

SIZE

1.5" Head Tube Reduced to 1-1/8" Fork Tube Semi-Integrated Threadless headset

SHIS NORM

ZS44/28.6
ZS55/39.8(30)

OPTIONAL

H156E:ZS44/28.6
ZS56/39.8(30)

可選配之上塞高度 (TOP COVER IS OPTIONAL)

型號(MODEL NO.): H156

型號(MODEL NO.): H156M

型號(MODEL NO.): H156H

型號(MODEL NO.): H156H

型號(MODEL NO.): H156H

型號(MODEL NO.): H156H

型號(MODEL NO.): H156H

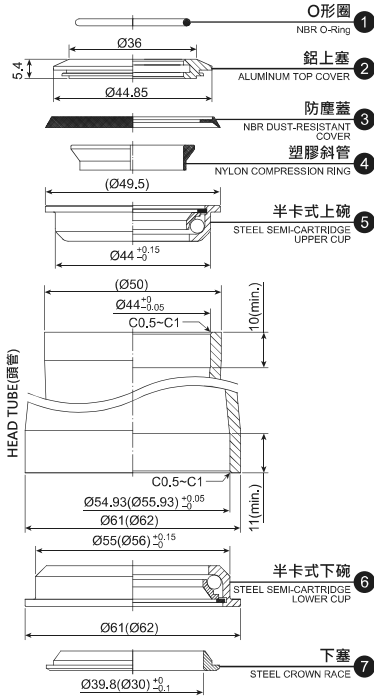

堆積高度 (STACK HEIGHT) = 9.9 ± 1 mm

H156MP [H156EMP]



WEIGHT

133g

SIZE

1.5" Head Tube Reduced to 1-1/8" Fork Tube Semi-Integrated Threadless headset

SHIS NORM

ZS44/28.6
ZS55/39.8(30)

OPTIONAL

H156EMP:ZS44/28.6
ZS56/39.8(30)

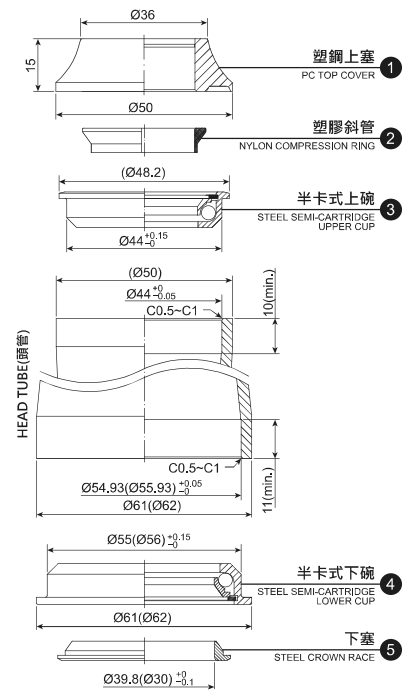

堆積高度 (STACK HEIGHT) = 19.5 ± 1 mm

H159 [H159E]



WEIGHT

127g

SIZE

1.5" Head Tube Reduced to 1-1/8" Fork Tube Semi-Integrated Threadless headset

SHIS NORM

ZS44/28.6
ZS55/39.8(30)

OPTIONAL

H159E:ZS44/28.6
ZS56/39.8(30)

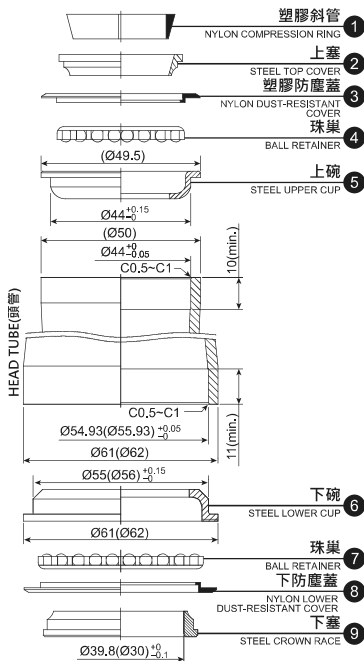

堆積高度 (STACK HEIGHT) = 9.7 ± 1 mm

H162



WEIGHT

82g

SIZE

1" Semi-Integrated Threadless Headset

SHIS NORM

ZS44/25.4
ZS44/27(26.4)

可選配之上塞高度 (TOP COVER IS OPTIONAL)

型號(MODEL NO.): H162

型號(MODEL NO.): H162M

型號(MODEL NO.): H162H

型號(MODEL NO.): H162H

型號(MODEL NO.): H162H

型號(MODEL NO.): H162H

型號(MODEL NO.): H162H

型號(MODEL NO.): H162H

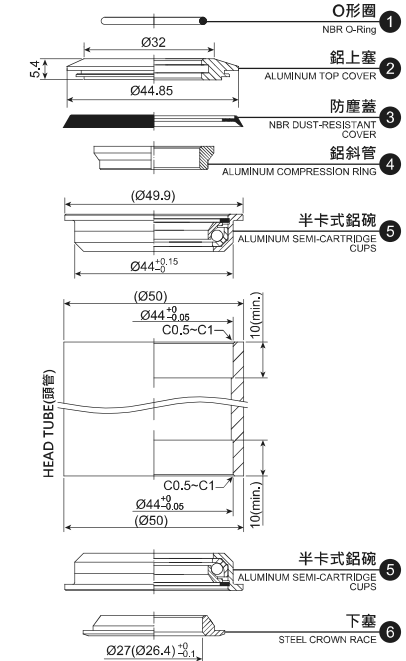

堆積高度 (STACK HEIGHT) = 9.1 ± 1 mm

H172



WEIGHT

75g

SIZE

1-1/8" Semi-Integrated
Threadless Headset

SHIS NORM

ZS44/28.6
ZS44/30

可選配之上塞高度
(TOP COVER IS OPTIONAL)

型號(MODEL NO.): H172



型號(MODEL NO.): H172M



型號(MODEL NO.): H172H

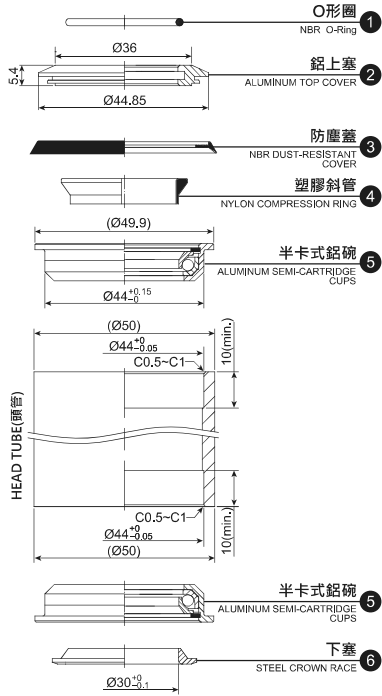

堆積高度 (STACK HEIGHT) = 9.1 ± 1 mm

H176



WEIGHT

112g

SIZE

1-1/8" Semi-Integrated
Threadless Headset

SHIS NORM

ZS44/28.6
ZS44/30

可選配之上塞高度
(TOP COVER IS OPTIONAL)

型號(MODEL NO.): H176



型號(MODEL NO.): H176M



型號(MODEL NO.): H176H

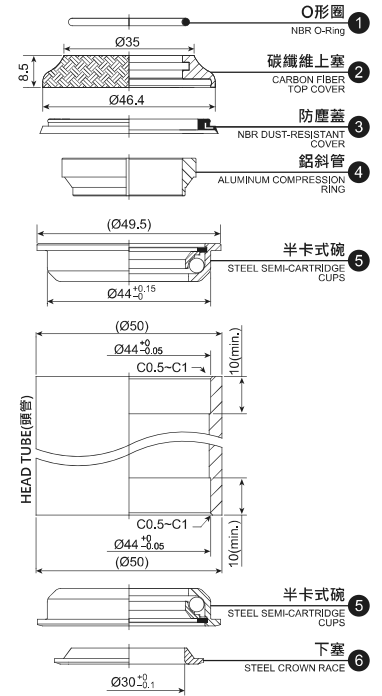

堆積高度 (STACK HEIGHT) = 14.6 ± 1 mm

H180



WEIGHT

75g

SIZE

1-1/8" Semi-Integrated
Threadless Headset

SHIS NORM

ZS44/28.6
ZS44/30

可選配之上塞高度
(TOP COVER IS OPTIONAL)

型號(MODEL NO.): H180



型號(MODEL NO.): H180M



型號(MODEL NO.): H180H

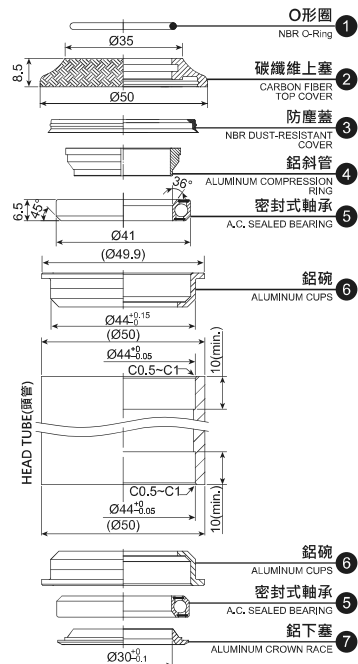

堆積高度 (STACK HEIGHT) = 13.7 ± 1 mm

H185



WEIGHT

98g

SIZE

1-1/8" Semi-Integrated
Threadless Headset

SHIS NORM

ZS44/28.6
ZS44/30

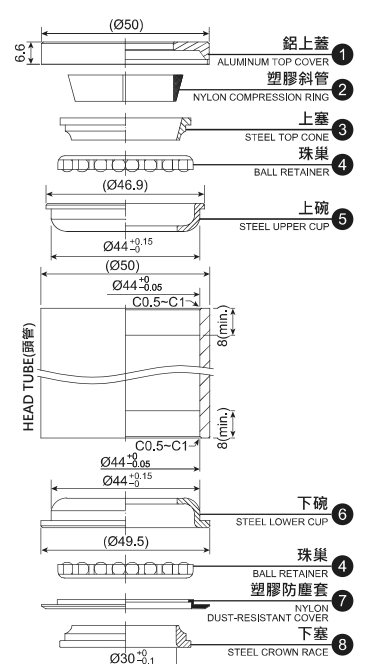

堆積高度 (STACK HEIGHT) = 11.7 ± 1 mm

NECO SEMI-INTEGRATED THREADLESS HEADSETS

半隱藏式無牙車頭碗 SEMI-INTEGRATED THREADLESS HEADSETS

H187



WEIGHT

130g

SIZE

1-1/4" Head Tube
Reduced to 1-1/8" Fork Tube
Semi-Integrated
Threadless Headset

SHIS NORM

ZS44/28.6
ZS50.6/33(30)

可選配之上塞高度
(TOP COVER IS OPTIONAL)

型號(MODEL NO.): H187



型號(MODEL NO.): H187M



型號(MODEL NO.): H187H

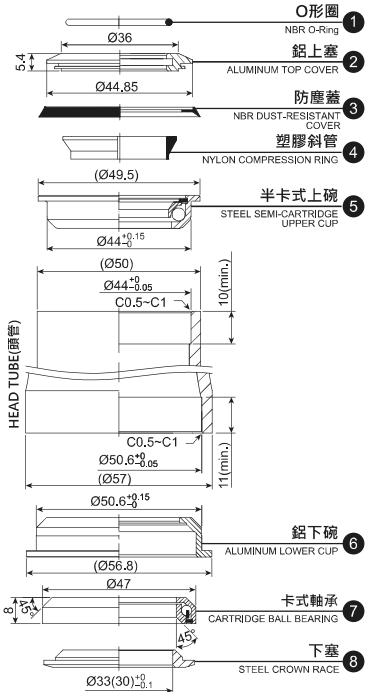
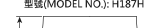

H188



WEIGHT

106g

SIZE

1-1/4" Head Tube
Reduced to 1-1/8" Fork Tube
Semi-Integrated
Threadless Headset

SHIS NORM

ZS44/28.6
ZS50.6/33(30)

可選配之上塞高度
(TOP COVER IS OPTIONAL)

型號(MODEL NO.): H188



型號(MODEL NO.): H188M



型號(MODEL NO.): H188H

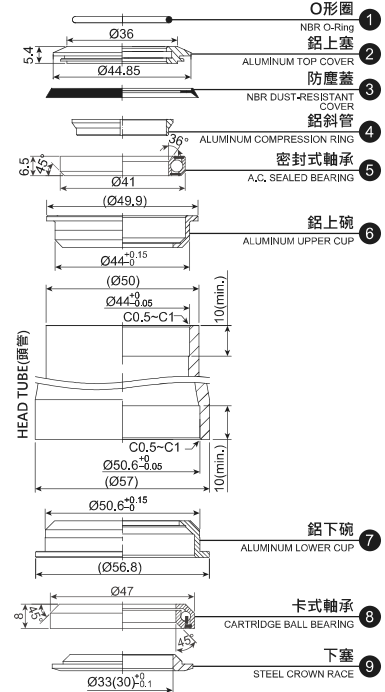
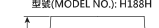

H189



WEIGHT

102g

SIZE

1-1/4" Reduced to
1-1/8" Fork Tube
Semi-Integrated
Threadless Headset

SHIS NORM

ZS41.4/28.6
ZS50.6/33(30)

可選配之上塞高度
(TOP COVER IS OPTIONAL)

型號(MODEL NO.): H189

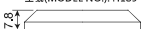

型號(MODEL NO.): H189M



型號(MODEL NO.): H189H

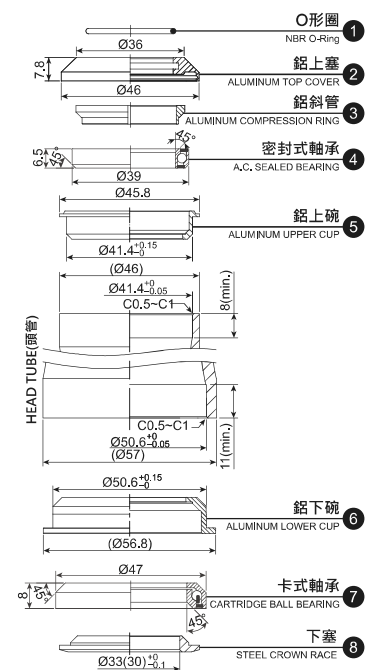

H332L

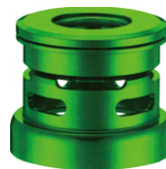

WEIGHT

82g

SIZE

1.5" Head Tube
Reduced to 1-1/8" Fork Tube
Semi-Integrated
+ External Cup
Threadless Headset

SHIS NORM

ZS49.7/28.6
EC49.7/39.8(30)

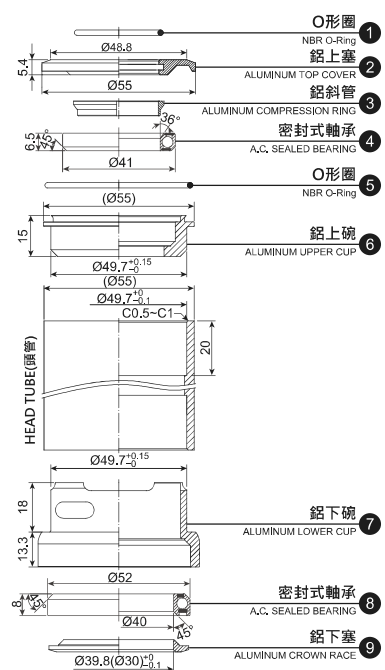

H369-3



WEIGHT

70g

SIZE

1-1/8"
Semi-Integrated
Threadless Headset

SHIS NORM

ZS41.4/28.6
ZS41.4 /30

可選配之上塞高度
(TOP COVER IS OPTIONAL)

型號(MODEL NO.): H369-3

型號(MODEL NO.): H369M-3

型號(MODEL NO.): H369H-3

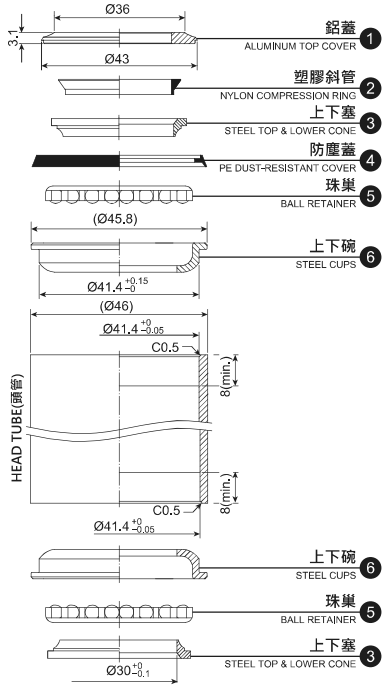
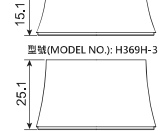

堆積高度 (STACK HEIGHT) = 10.2 ± 1 mm

H383 [H383A]

H384 [H384A]



WEIGHT

106g

SIZE

1.5" Head Tube Reduced
to 1-1/8" Fork Tube
Semi-Integrated
Threadless Headset

SHIS NORM

ZS44/28.6
ZS55/39.8 (H383)

OPTIONAL

H384 #6 Crown Race
ID:30.0mm

SHIS NORM

ZS44/28.6
ZS55/30(H384)

OPTIONAL MATERIAL

H383A/H384A :
Aluminum lower cup
and Crown Race

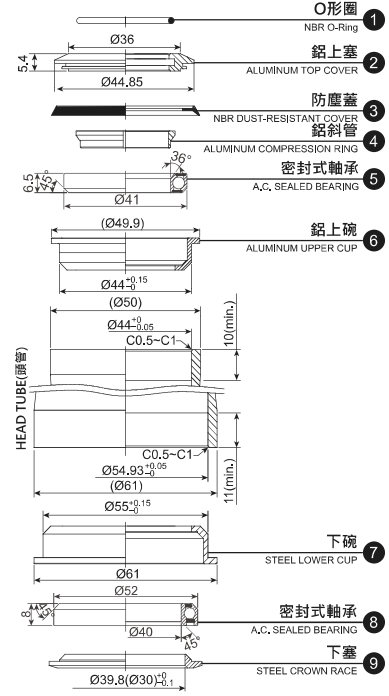

堆積高度 (STACK HEIGHT) = 9.5 ± 1 mm

H383AE [H384AE]



WEIGHT

105g

SIZE

1.5" Head Tube Reduced to
1-1/8" Fork Tube Semi-
Integrated Threadless Headset

SHIS NORM

ZS44/28.6
ZS56/39.8(H383AE)

OPTIONAL

H384AE #6 Crown
Race ID:30.0mm

SHIS NORM

ZS44/28.6
ZS56/30(H384AE)

可選配之上塞高度
(TOP COVER IS OPTIONAL)

型號(MODEL NO.):H383AE(H384AE)

型號(MODEL NO.):H383AEM(H384AEM)

型號(MODEL NO.):H383AEH(H384AEH)

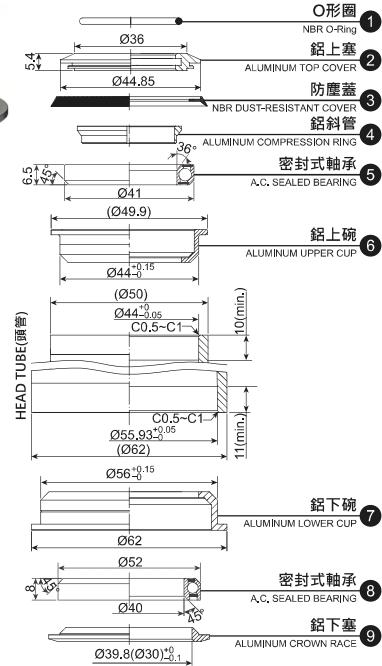
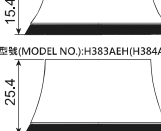

堆積高度 (STACK HEIGHT) = 9.5 ± 1 mm

H385 [H385E]

H386 [H386E]



WEIGHT

97g

SIZE

1.5" Head Tube
Reduced to 1-1/8"
Fork Tube
Semi-Integrated
Threadless Headset

SHIS NORM

ZS44/28.6
ZS55/39.8 (H385)

OPTIONAL

ZS44/28.6
ZS55/30(H386)

OPTIONAL

H385E/H386E:
Lower Head
Tube ID/OD.
=56/62mm

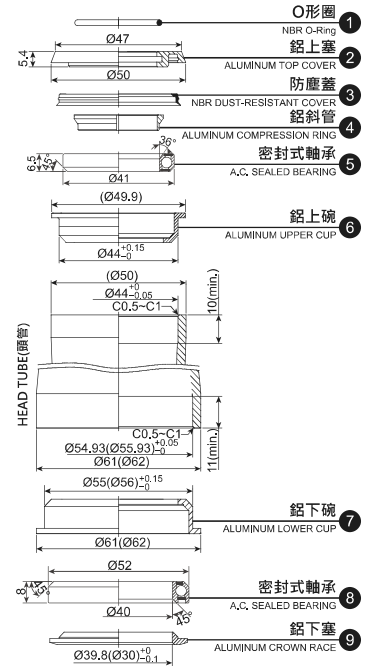

堆積高度 (STACK HEIGHT) = 9.5 ± 1 mm

NECO SEMI-INTEGRATED THREADED HEADSETS

半隱藏式有牙車頭碗 SEMI-INTEGRATED THREADED HEADSETS

H108 [H108H]



WEIGHT

106g

SIZE

1" Semi-Integrated Threaded Headset

DIMENSIONS

Ø22.2x44/
50x27(26.4)

可選配之上塞高度
(TOP COVER IS OPTIONAL)

型號(MODEL NO.): H108

13.6

型號(MODEL NO.): H108H

25.2

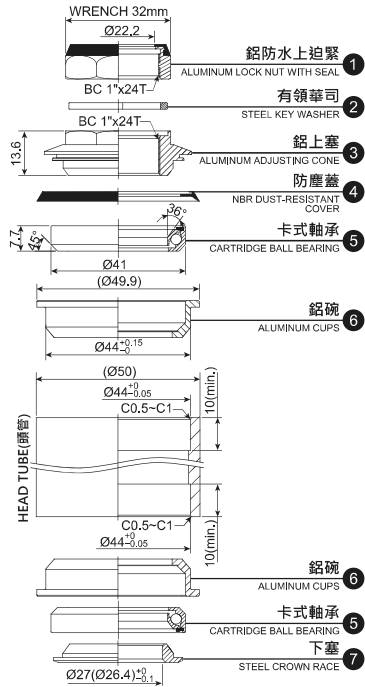

堆積高度 (STACK HEIGHT) = 23.2 ± 1 mm

H112N



WEIGHT

171g

SIZE

1-1/8" Semi-Integrated Threaded Headset w/Alloy Cover

DIMENSIONS

Ø25.4x44/50x30

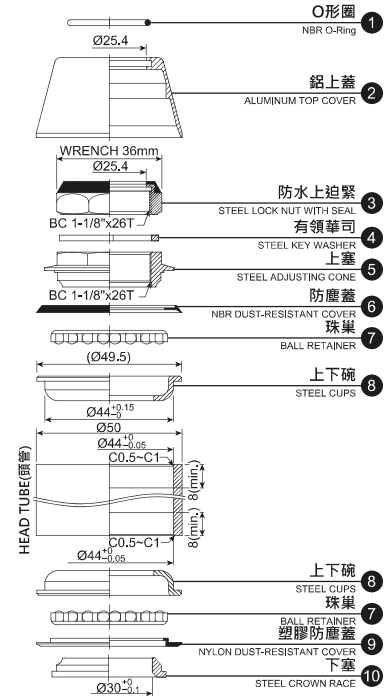

堆積高度 (STACK HEIGHT) = 25.5 ± 1 mm

H113N



WEIGHT

163g

SIZE

1-1/8" Semi-Integrated Threaded Headset w/Plastic Cover

DIMENSIONS

Ø25.4x44/50x30

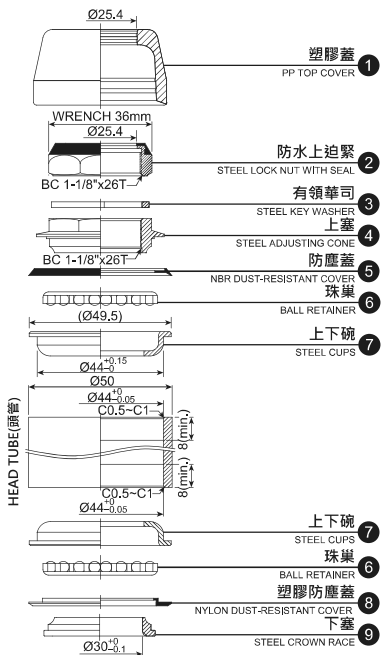

堆積高度 (STACK HEIGHT) = 25.5 ± 1 mm

H118 [H118H]



WEIGHT

103g

SIZE

1-1/8" Semi-Integrated Threaded Headset

DIMENSIONS

Ø25.4x44/50x30

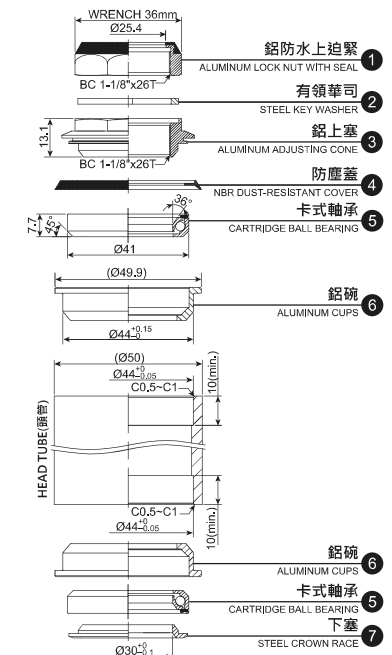
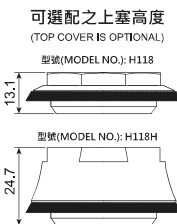

堆積高度 (STACK HEIGHT) = 23.5 ± 1 mm

H127



WEIGHT

128g

SIZE

1" Semi-Integrated
Threaded Headset

DIMENSIONS

Ø22.2x41.4/
46x27(26.4)

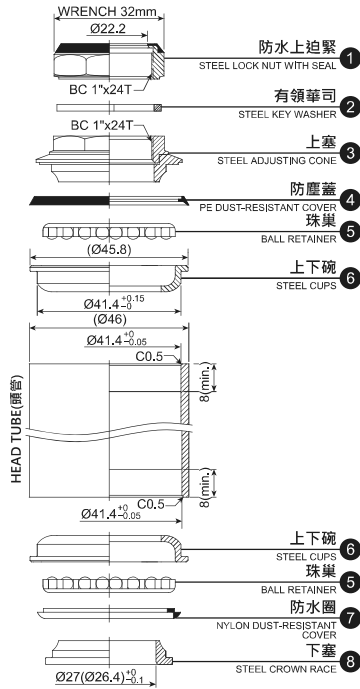

堆積高度 (STACK HEIGHT) = 25.2 ± 1 mm

H128N



WEIGHT

153g

SIZE

1-1/8"
Semi-Integrated
Threaded Headset

DIMENSIONS

Ø25.4x44/50x30

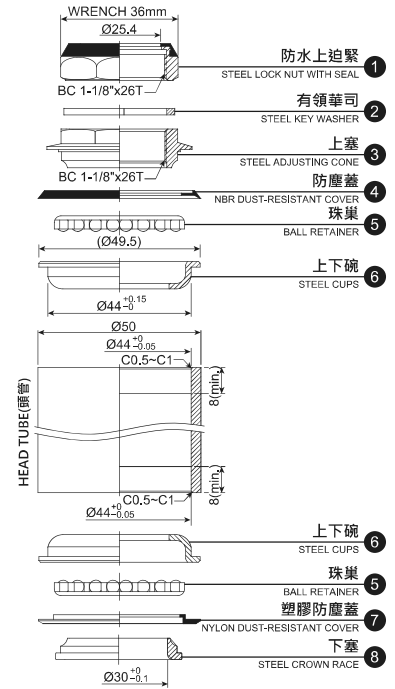

堆積高度 (STACK HEIGHT) = 25.5 ± 1 mm

H129



WEIGHT

155g

SIZE

1-1/8"
Semi-Integrated
Threaded Headset

DIMENSIONS

Ø25.4x44/50x30

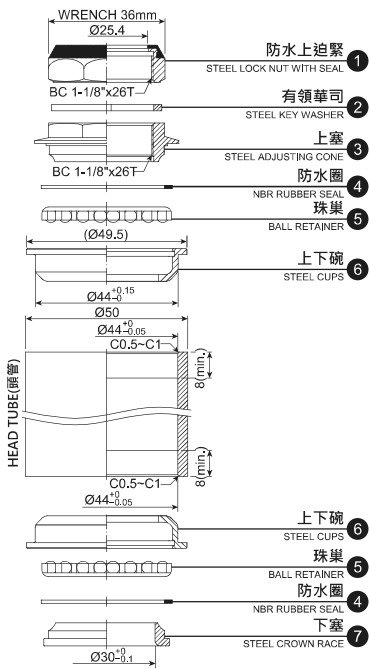

堆積高度 (STACK HEIGHT) = 23.5 ± 1 mm

H161L [H161H]



WEIGHT

H161L: 127g
H161H: 150g

SIZE

1" Semi-Integrated
Threaded Headset

DIMENSIONS

Ø22.2x44/
50x27(26.4)

可選配之上塞高度
(ADJUSTING CONE IS OPTIONAL)

型號(MODEL NO.): H161L

型號(MODEL NO.): H161H

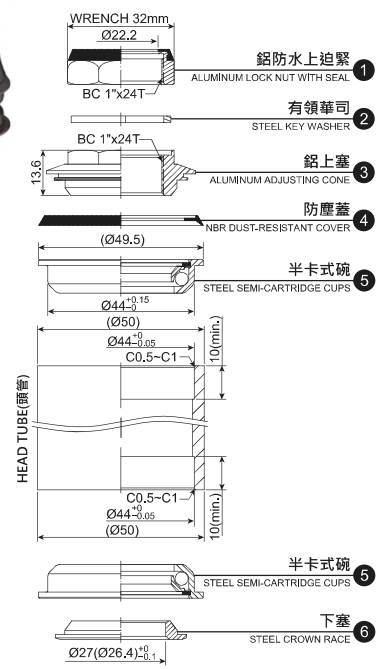
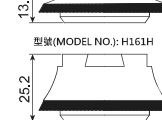

堆積高度 (STACK HEIGHT) = 23.7 ± 1 mm

H186



WEIGHT

130g

SIZE

1-1/8"
Semi-Integrated
Threaded Headset

DIMENSIONS

Ø28.6x44/50x30

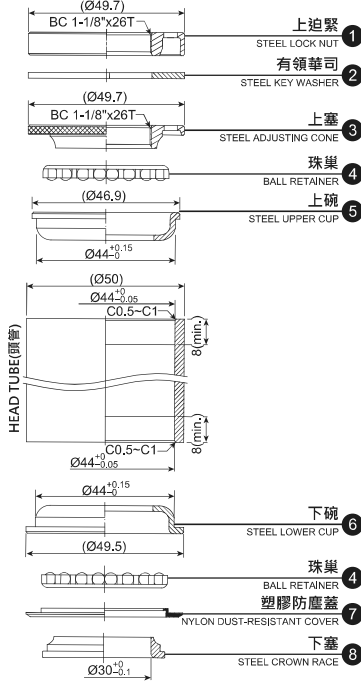

堆積高度 (STACK HEIGHT) = 17.7 ±1 mm



H151BW [1.5"]

1.5" OVERSIZE HEADSET SEALED BEARING LIGHT ALLOY



WEIGHT

175.5g

SIZE

1-1/2" Threadless
Headset

SHIS NORM

EC49.7/38.1
EC49.7/39.8

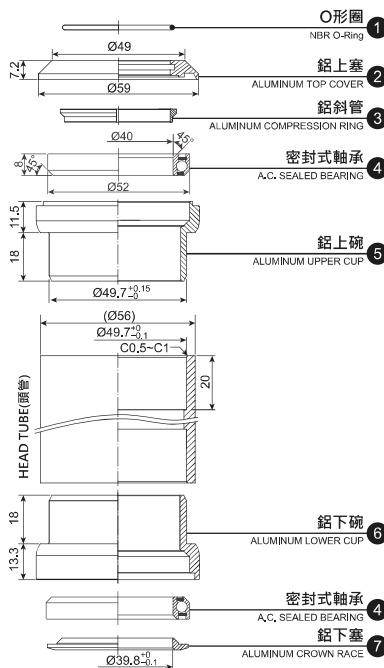

堆積高度 (STACK HEIGHT) = 32 ±1 mm

H153BW

1.5" REDUCED TO 1-1/8" SEALED BEARING LIGHT ALLOY



WEIGHT

194g

SIZE

1.5" Head Tube Reduced
to 1-1/8" Fork Tube
Semi-Integrated
Threadless Headset

SHIS NORM

EC49.7/28.6
EC49.7/30

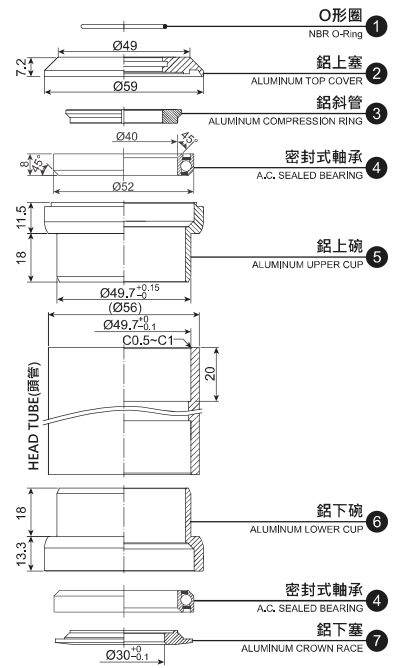

堆積高度 (STACK HEIGHT) = 32 ±1 mm

NECO EXTERNAL CUP THREADLESS HEADSETS

外露式無牙車頭碗 EXTERNAL CUP THREADLESS HEADSETS

H252



WEIGHT

98.6g

SIZE

1" Threadless
Headset

SHIS NORM

EC30/25.4
EC30/27(26.4)

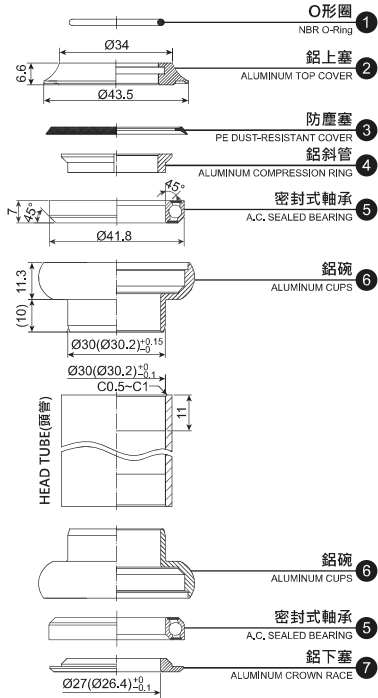

堆積高度 (STACK HEIGHT) = 29 ±1 mm

H282



OPTIONAL H282O

WEIGHT

95g

SIZE

1-1/8" Threadless
Headset

SHIS NORM

EC34/28.6
EC34/30

OPTIONAL

H282O:EC34/28.6
EC34/30
Height:27±1mm

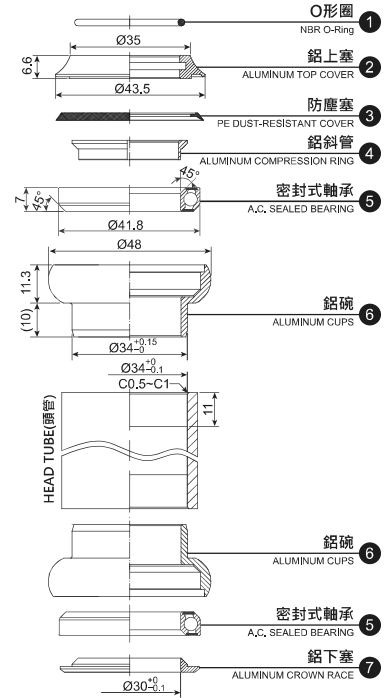

堆積高度 (STACK HEIGHT) = 29 ±1 mm

H370



WEIGHT

115g

SIZE

1-1/8" Threadless
Headset

SHIS NORM

EC34/28.6
EC34/30

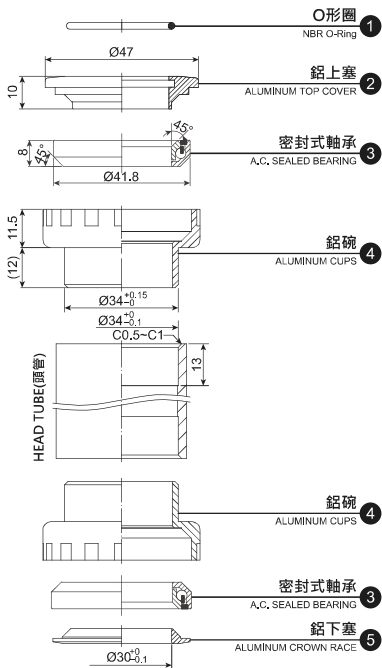

堆積高度 (STACK HEIGHT) = 28.3 ±1 mm

H610



WEIGHT

104g

SIZE

1" Threadless
Headset

SHIS NORM

EC30/25.4
EC30/27(26.4)

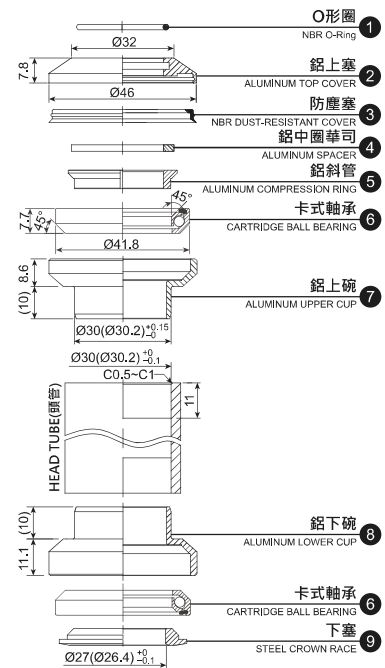

堆積高度 (STACK HEIGHT) = 29 ±1 mm

H626



WEIGHT

103.1g

SIZE

1" Threadless Headset

SHIS NORM

EC30/25.4
EC30/27(26.4)

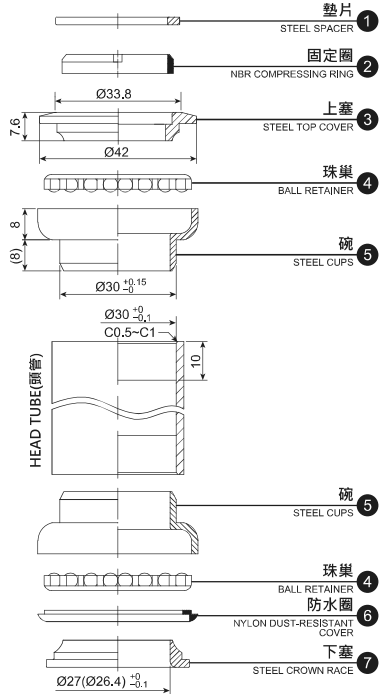

堆積高度 (STACK HEIGHT) = 24.5 ±1 mm

H673



WEIGHT

92g

SIZE

1" Threadless Headset

SHIS NORM

EC30/25.4
EC30/27(26.4)

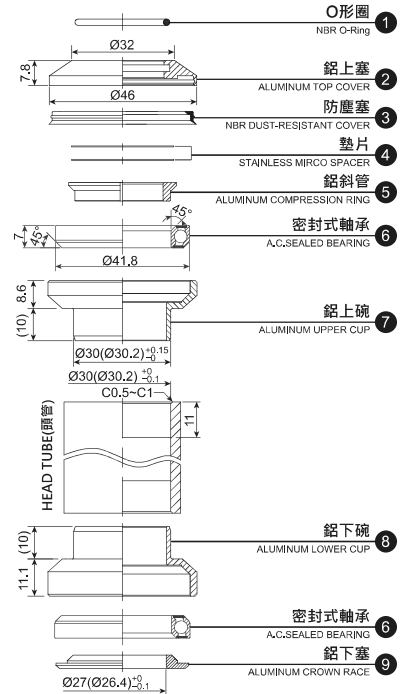

堆積高度 (STACK HEIGHT) = 29.5 ±1 mm

H701

Smart design that gives an integrated style-like look



WEIGHT

92g

SIZE

1-1/8" Threadless Headset

SHIS NORM

EC34/28.6
EC34/30

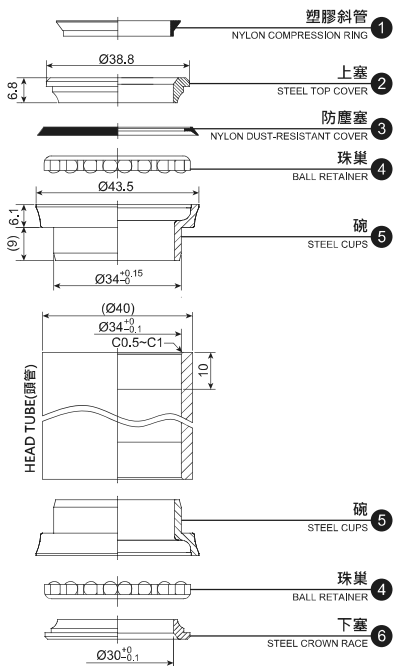

堆積高度 (STACK HEIGHT) = 20 ±1 mm

H705PS



WEIGHT

120g

SIZE

1-1/8" Reduced to 1" Threadless Steerer

SHIS NORM

EC34/25.4
EC34/30

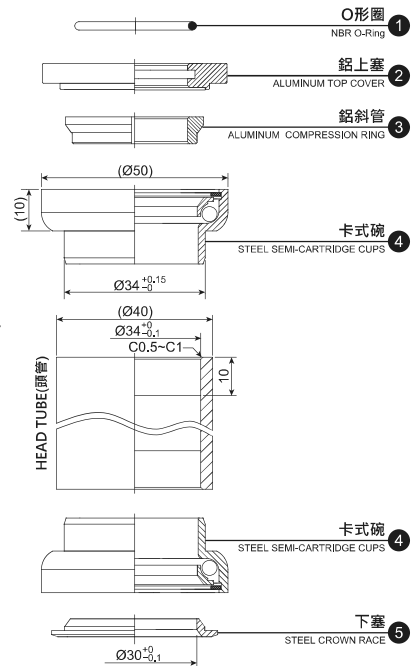

堆積高度 (STACK HEIGHT) = 28.3 ±1 mm

NECO EXTERNAL CUP THREADLESS HEADSETS

外露式無牙車頭碗 EXTERNAL CUP THREADLESS HEADSETS

H706 [H706M]

Smart Design That Gives An Integrated Style-Like Look



WEIGHT

95g

SIZE

1-1/8" Threadless Headset

SHIS NORM

EC34/28.6
EC34/30

可選配之上塞高度
(TOP COVER IS OPTIONAL)
型號(MODEL NO.): H706

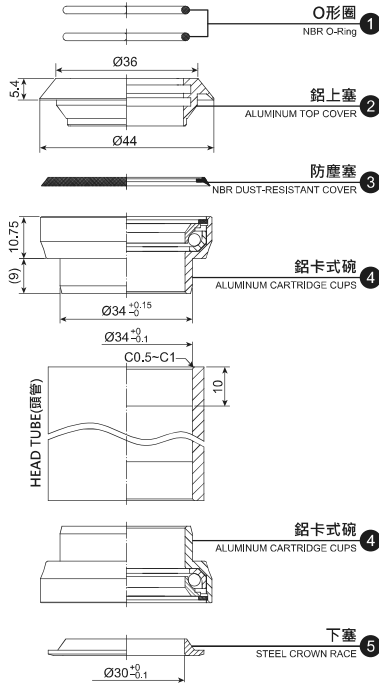
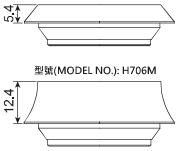

堆積高度 (STACK HEIGHT) = 28.6 ± 1 mm

H711



WEIGHT

112g

SIZE

1-1/8" Threadless Headset

SHIS NORM

EC34/28.6
EC34/30

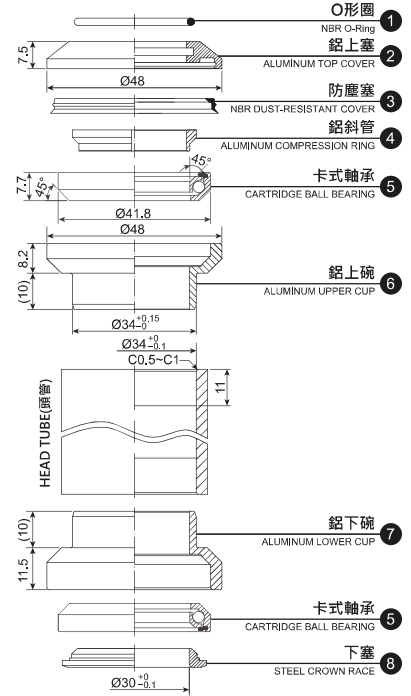

堆積高度 (STACK HEIGHT) = 29 ± 1 mm

H773



WEIGHT

102g

SIZE

1-1/8" Threadless Headset

SHIS NORM

EC34/28.6
EC34/30

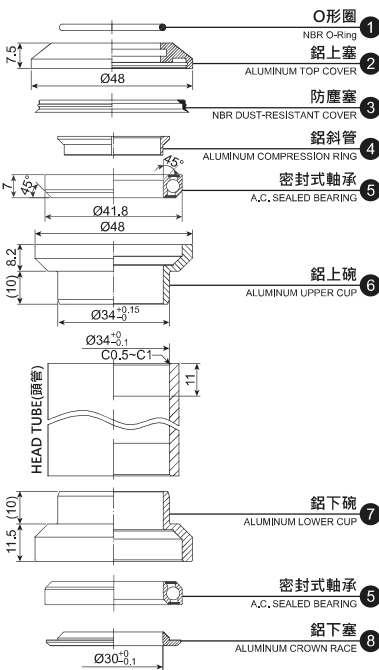

堆積高度 (STACK HEIGHT) = 29 ± 1 mm

H773L



WEIGHT

151g

SIZE

1.5" Head Tube
Reduced to 1-1/8"

SHIS NORM

EC34/28.6
EC49.7/39.8(30)

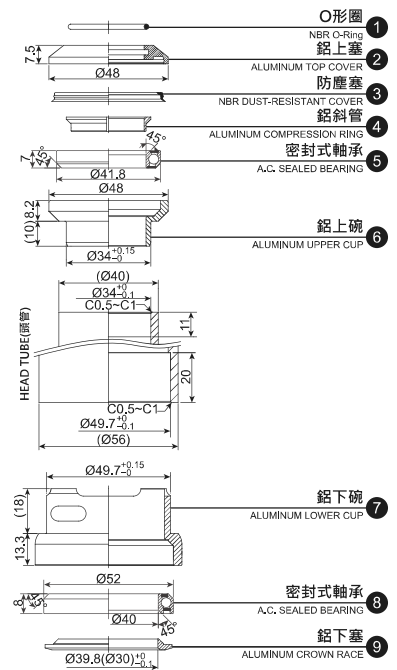

堆積高度 (STACK HEIGHT) = 30.4 ± 1 mm

H825



WEIGHT

114g

SIZE

1" Threadless Headset

SHIS NORM

EC30/25.4
EC30/27(26.4)

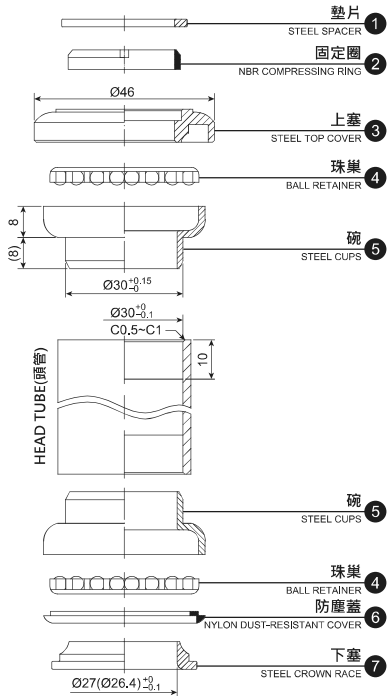

堆積高度 (STACK HEIGHT) = 25±1 mm

H827W



WEIGHT

102g

SIZE

1" Threaded Headset

SHIS NORM

EC30/25.4
EC30/27(26.4)

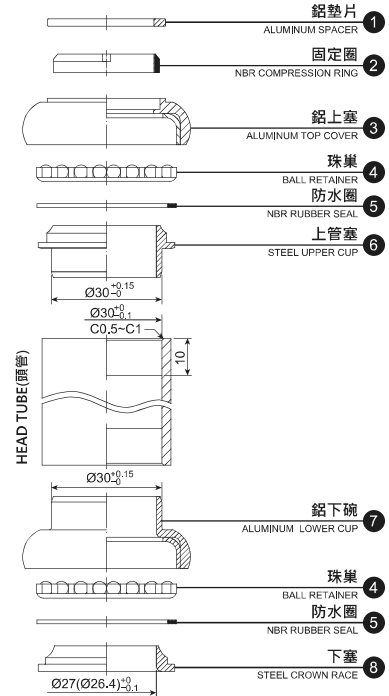

堆積高度 (STACK HEIGHT) = 28.2±1 mm

H845



WEIGHT

169g

SIZE

1-1/8" Threadless Headset

SHIS NORM

EC34/28.6
EC34/30

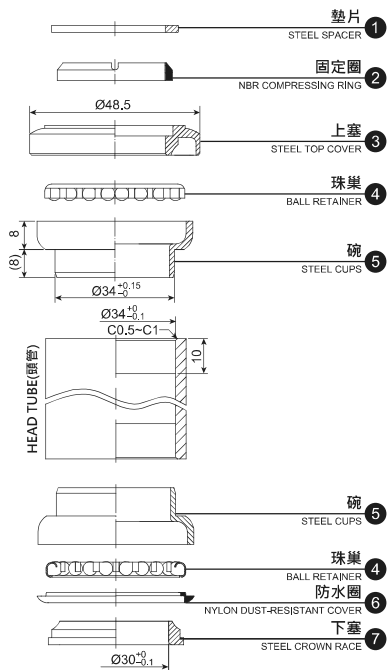

堆積高度 (STACK HEIGHT) = 26.5 ±1 mm

H846



WEIGHT

144g

SIZE

1-1/8" Threadless Headset

SHIS NORM

EC34/28.6
EC34/30

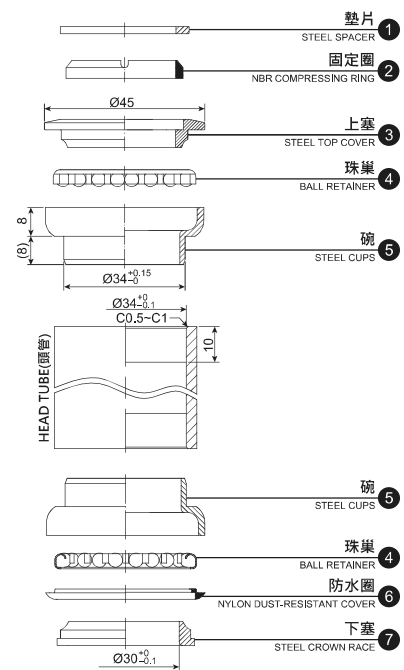

堆積高度 (STACK HEIGHT) = 25 ±1 mm

NECO EXTERNAL CUP THREADLESS HEADSETS

外露式無牙車頭碗 EXTERNAL CUP THREADLESS HEADSETS

H847W



WEIGHT

125g

SIZE

1-1/8" Threadless Headset

SHIS NORM

EC34/28.6
EC34/30

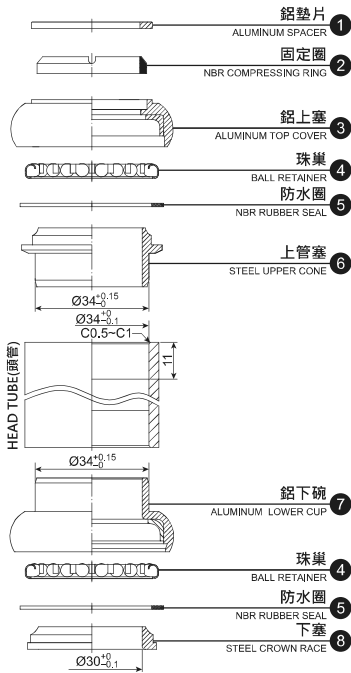

堆積高度 (STACK HEIGHT) = 31±1 mm

H852



WEIGHT

105g

SIZE

1-1/8" Threadless Headset

SHIS NORM

EC34/28.6
EC34/30

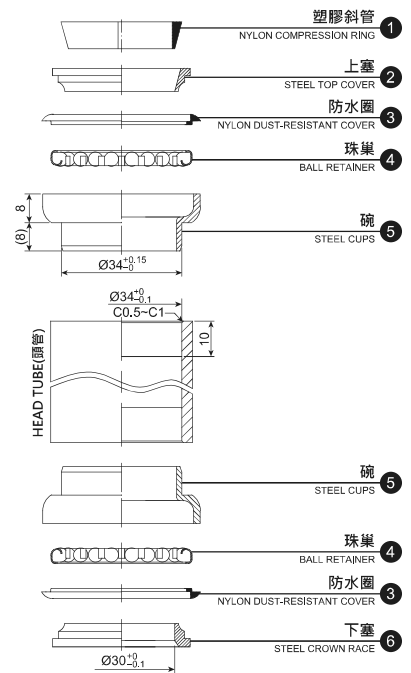

堆積高度 (STACK HEIGHT) = 22±1 mm

H854



WEIGHT

120g

SIZE

1-1/8" Threadless Headset

SHIS NORM

EC34/28.6
EC34/30

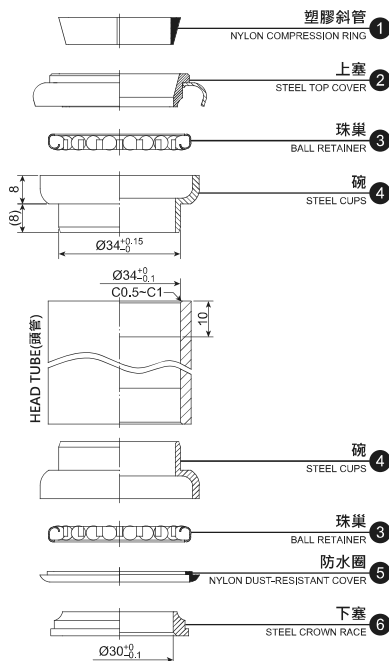

堆積高度 (STACK HEIGHT) = 25±1 mm

H855 [H826]



WEIGHT

163g

SIZE

1-1/8" Threadless Headset

SHIS NORM

EC34/28.6
EC34/30

OPTIONAL

H826 EC30/25.4
EC30/27 (26.4)
STACK HEIGHT = 25.6mm

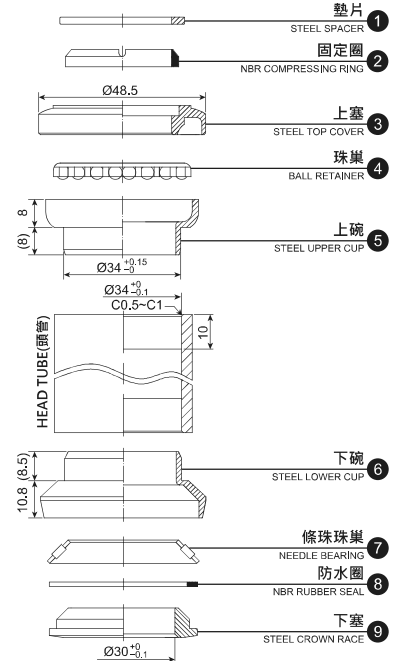

堆積高度 (STACK HEIGHT) = 28.4 ± 1 mm

H867EW [H236EW]



WEIGHT

127g

SIZE

1-1/8" Threadless Headset

SHIS NORM

EC34/28.6
EC34/30

OPTIONAL

H236EW EC30/25.4
EC30/27(26.4)
STACK HEIGHT
=28.2mm

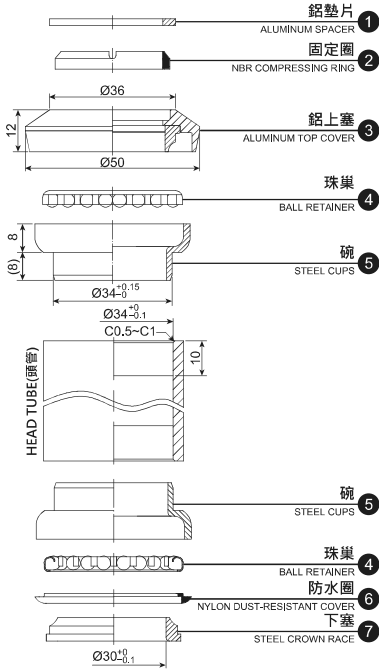

堆積高度 (STACK HEIGHT) = 28±1 mm

H878



WEIGHT

142g

SIZE

1-1/8" Threadless Headset

SHIS NORM

EC34/28.6
EC34/30

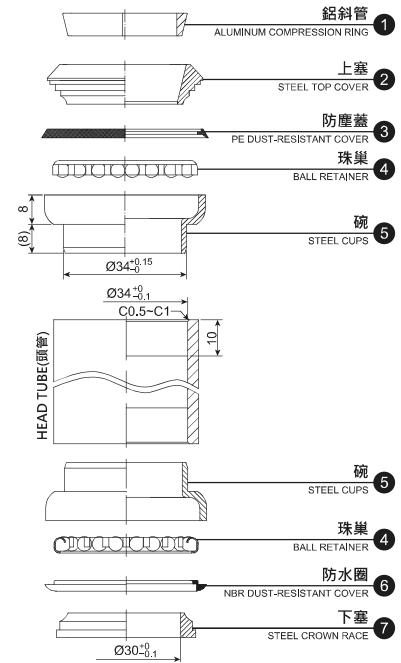

堆積高度 (STACK HEIGHT) = 26.5±1 mm

H879

BIG LOWER CUP FOR HEAVY DUTY



WEIGHT

180g

SIZE

1-1/8" Threadless Headset

SHIS NORM

EC34/28.6
EC34/30

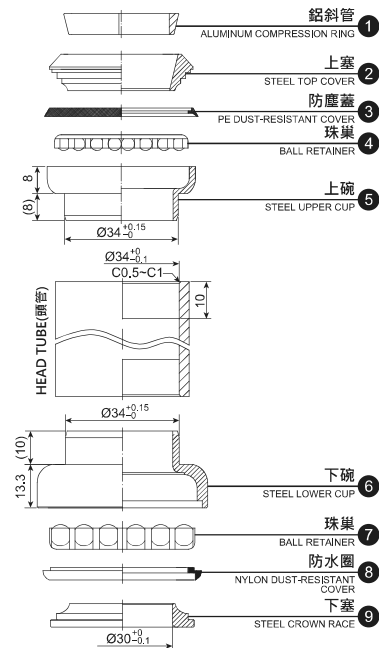

堆積高度 (STACK HEIGHT) = 30.4±1 mm



H130 130° 1" SAFETY HEADSET



WEIGHT

127g

SIZE

1" Threaded Safety Headset

DIMENSIONS

Ø22.2x30x27

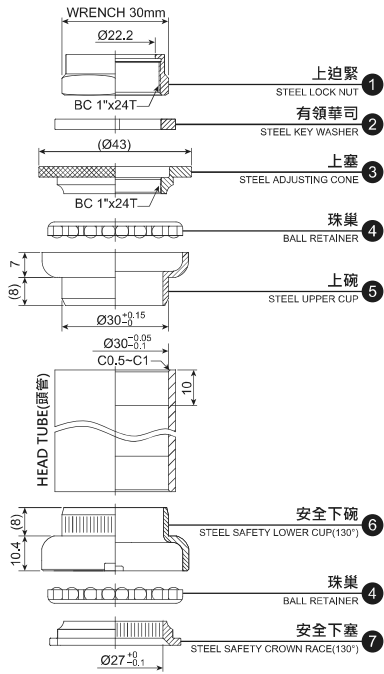

堆積高度 (STACK HEIGHT) = 34.5 ± 1 mm

H134 130° 1" SAFETY HEADSET



WEIGHT

116g

SIZE

1" Threadless Safety Headset

SHIS NORM

EC30/25.4
EC30/27

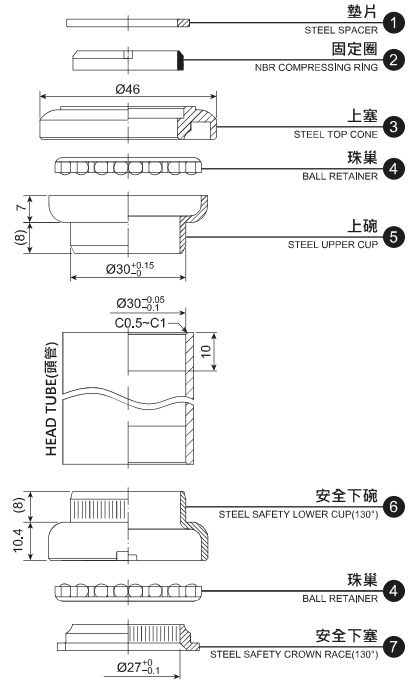

堆積高度 (STACK HEIGHT) = 25.5 ± 1 mm

H135 130° 1-1/8" SAFETY HEADSET



WEIGHT

142g

SIZE

1-1/8" Threadless Safety Headset

SHIS NORM

EC34/28.6
EC34/30

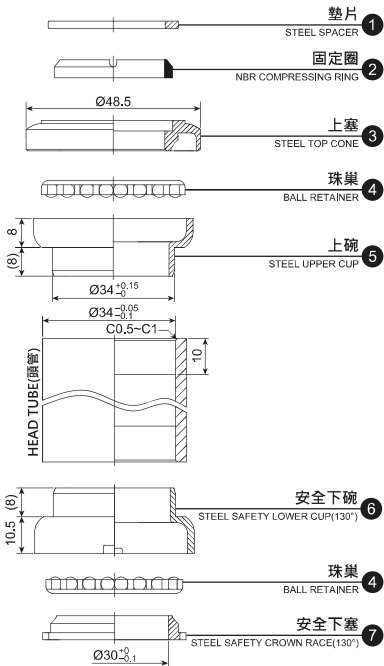

堆積高度 (STACK HEIGHT) = 27.5 ± 1 mm

H139 130° 1" SAFETY HEADSET



WEIGHT

136g

SIZE

1" Threaded Safety Headset

DIMENSIONS

Ø22.2x30x27

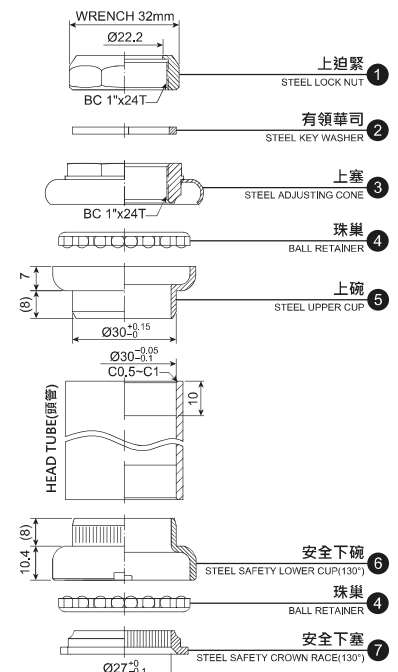

堆積高度 (STACK HEIGHT) = 37 ± 1 mm

H140 130° 1-1/8" SAFETY HEADSET



WEIGHT

164g

SIZE

1-1/8" Threaded Safety Headset

DIMENSIONS

Ø25.4x34x30

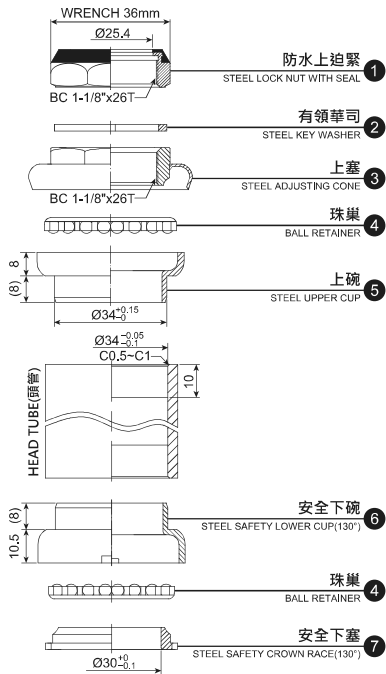

堆積高度 (STACK HEIGHT) = 38.5 ± 1 mm

H128-130 130° 1-1/8" SAFETY SEMI-INTEGRATED HEADSET



WEIGHT

154g

SIZE

1-1/8" Semi-Integrated Threaded Safety Headset

DIMENSIONS

Ø25.4x44/50x30

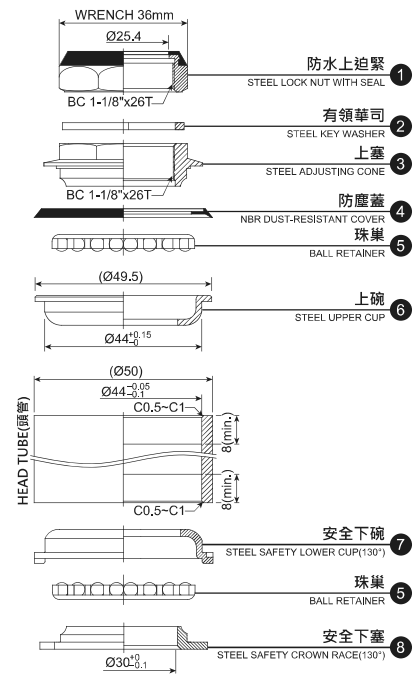

堆積高度 (STACK HEIGHT) = 26.5 ± 1 mm

H128-130SA 130° 1-1/8" SAFETY SEMI-INTEGRATED HEADSET



WEIGHT

164.8g

SIZE

1-1/8" Semi-Integrated Threaded Safety Headset

DIMENSIONS

Ø25.4x44/50x30

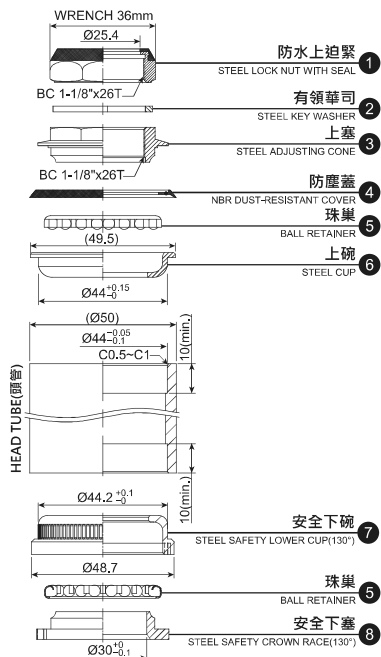

堆積高度 (STACK HEIGHT) = 26.9 ± 1 mm

H146-130SB 130° 1-1/8" SAFETY SEMI-INTEGRATED HEADSET



WEIGHT

108.1g

SIZE

1-1/8" Semi-Integrated Threadless Safety Headset

SHIS NORM

ZS44/28.6
ZS44/30

可選配之上塞高度 (TOP COVER IS OPTIONAL)

型號 (MODEL NO.): H146-130SB

型號 (MODEL NO.): H146M-130SB

型號 (MODEL NO.): H146H-130SB

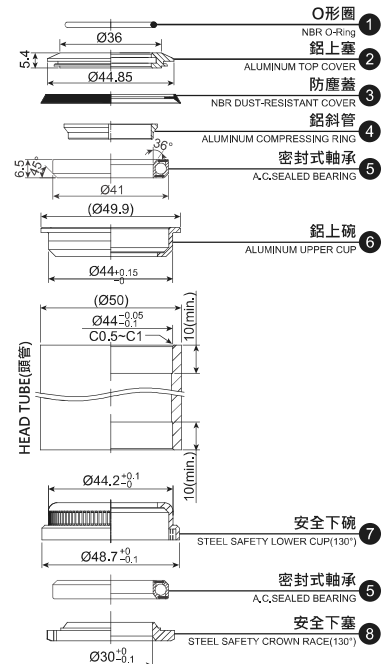
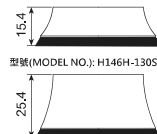

堆積高度 (STACK HEIGHT) = 12.1 ± 1 mm

H148-130 130° 1-1/8" SAFETY SEMI-INTEGRATED HEADSET



WEIGHT
100.8g

SIZE
1-1/8"
Semi-Integrated
Threadless Safety
Headset

SHIS NORM
ZS44/28.6
ZS44/30

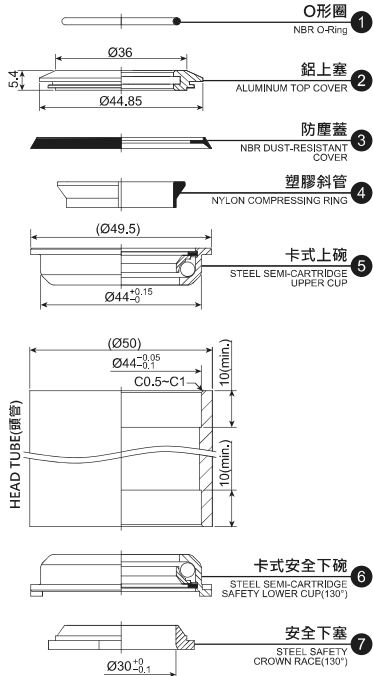

堆積高度 (STACK HEIGHT) = 11.6 ± 1 mm

H148-130SA 130° 1-1/8" SAFETY SEMI-INTEGRATED HEADSET



WEIGHT
105g

SIZE
1-1/8"
Semi-Integrated
Threaded Safety
Headset

DIMENSIONS
ZS44/28.6
ZS44/30

可選配之上塞高度 (TOP COVER IS OPTIONAL)

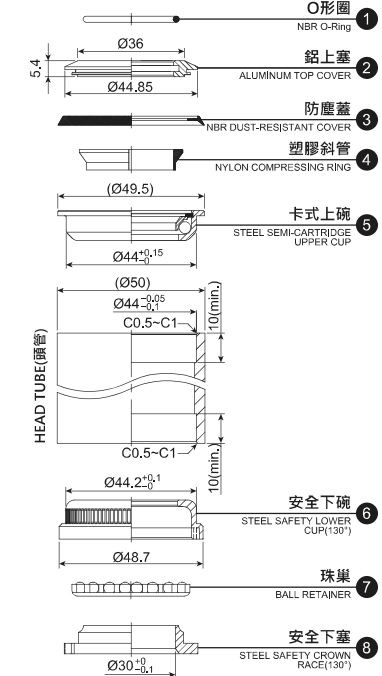
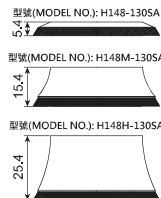

堆積高度 (STACK HEIGHT) = 12.8 ± 1 mm

H153-1SB 130° 1.5" SAFETY SEMI-INTEGRATED HEADSET

H153E-1SB



WEIGHT
224.9g

SIZE
1.5" Head Tube
Reduce to 1-1/8"
Fork Tube
Semi-Integrated
Threadless Safety
Headset

SHIS NORM
ZS55/28.6
ZS55/39.8(30)

OPTIONAL
H153E-1SB
ZS56/28.6
ZS56/39.8(30)

可選配之上塞高度 (TOP COVER IS OPTIONAL)

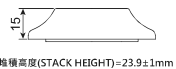

堆積高度 (STACK HEIGHT) = 23.9 ± 1 mm

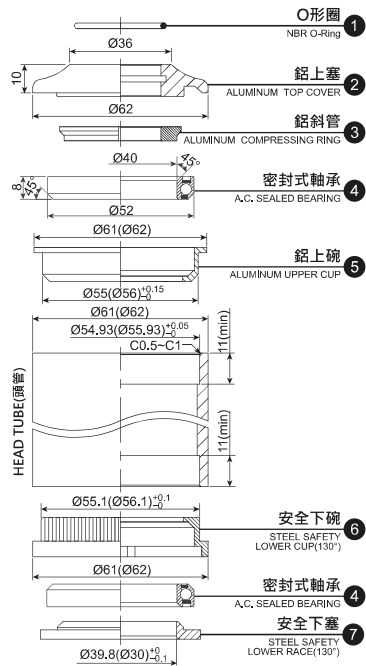

堆積高度 (STACK HEIGHT) = 18.9 ± 1 mm

H158-SA 130° 1.5" SAFETY SEMI-INTEGRATED HEADSET

H158ESA



WEIGHT
258.5g

SIZE
1.5" Head Tube
Reduce to 1-1/8"
Fork Tube
Semi-Integrated
Threaded Safety
Headset

DIMENSIONS
Ø25.4x55
/61x39.8(30)

OPTIONAL
H158ESA
Ø25.4x56
/62x39.8(30)

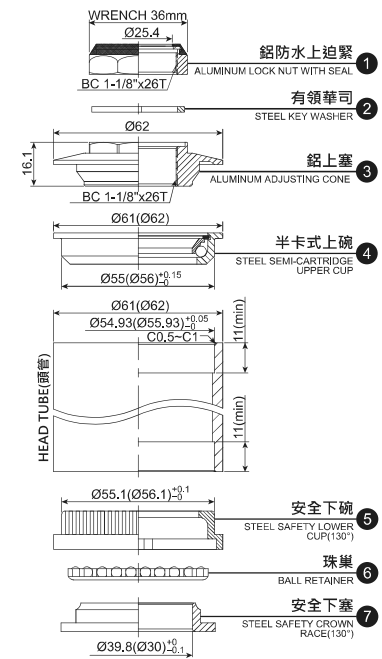

堆積高度 (STACK HEIGHT) = 27.2 ± 1 mm

H382S-152SB



WEIGHT

113.3g

SIZE

1.5"Head Tube
Reduced To 1-1/8"
Fork Tube Integrated
Threadless Headset

SHIS NORM

IS52.2/28.6
ZS52/30

可選配之上塞高度
(TOP COVER IS OPTIONAL)
型號(MODEL NO.): H382SM-152SB

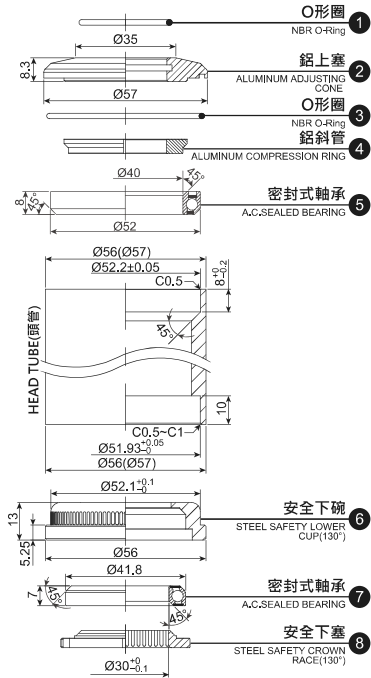

堆積高度 (STACK HEIGHT) = 13.7 ± 1 mm

H231



WEIGHT

116.5g

SIZE

1-1/8"x 26T

DIMENSIONS

Ø28.6x34x30

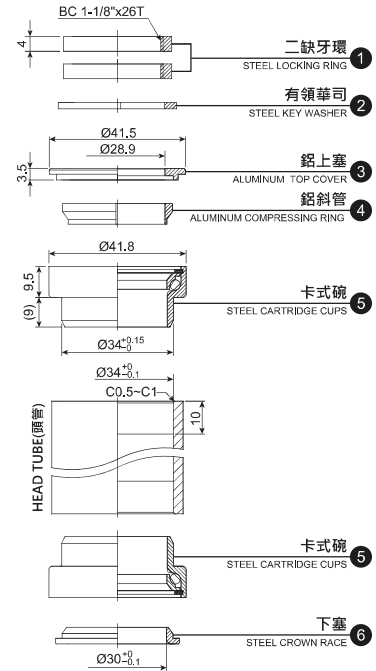

堆積高度 (STACK HEIGHT) = 34 ± 1 mm

H617



WEIGHT

101.8g

SIZE

1"x24T

DIMENSIONS

Ø22.2x30x27(26.4)

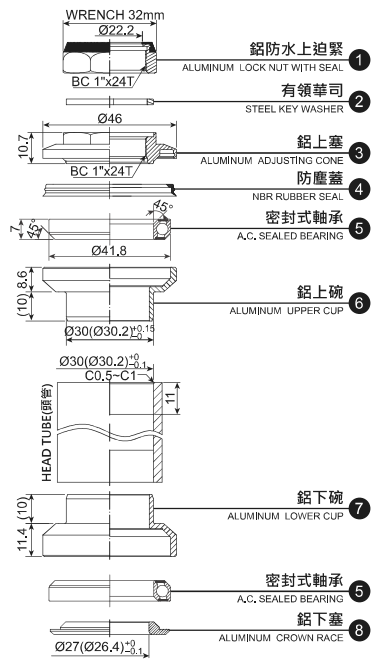

堆積高度 (STACK HEIGHT) = 40.5 ± 1 mm

H671



WEIGHT

117g

SIZE

1"x24T

DIMENSIONS

Ø22.2x30x27(26.4)

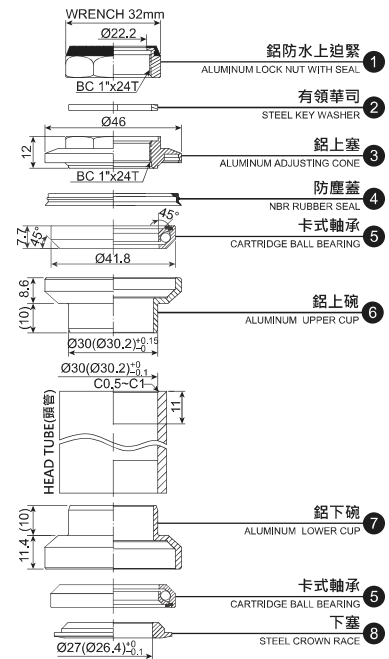

堆積高度 (STACK HEIGHT) = 40.5 ± 1 mm

NECO EXTERNAL CUP THREADED HEADSETS

外露式有牙車頭碗 EXTERNAL CUP THREADED HEADSETS

H717



WEIGHT

116g

SIZE

1-1/8"x26T

DIMENSIONS

Ø25.4x34x30

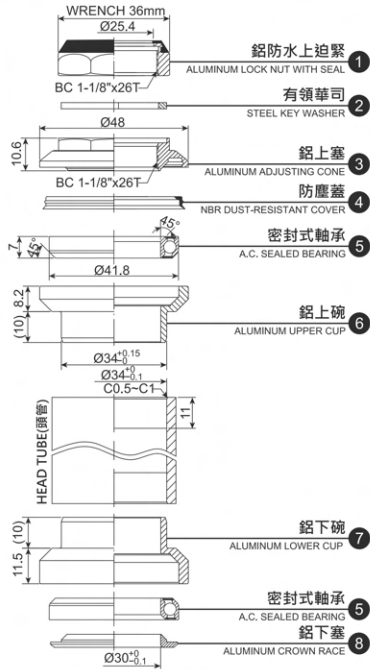

堆積高度 (STACK HEIGHT) = 40.5 ± 1 mm

H771



WEIGHT

120g

SIZE

1-1/8"x26T

DIMENSIONS

Ø25.4x34x30

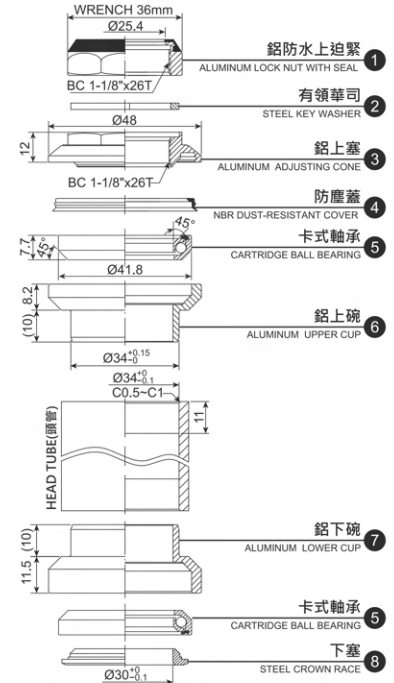

堆積高度 (STACK HEIGHT) = 40.8 ± 1 mm

H800K



WEIGHT

123g

SIZE

1"x24T

DIMENSIONS

Ø22.2x30x27(26.4)

OPTIONAL

H800D Plain Washer (w/o nose)
H800T Threaded Washer
H800C Semi-Cartridge Cups

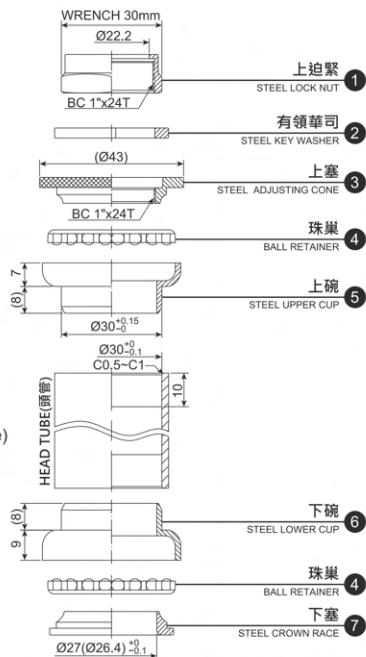

堆積高度 (STACK HEIGHT) = 34.3 ± 1 mm

H801K



WEIGHT

139g

SIZE

1"x24T

DIMENSIONS

Ø22.2x30x27(26.4)

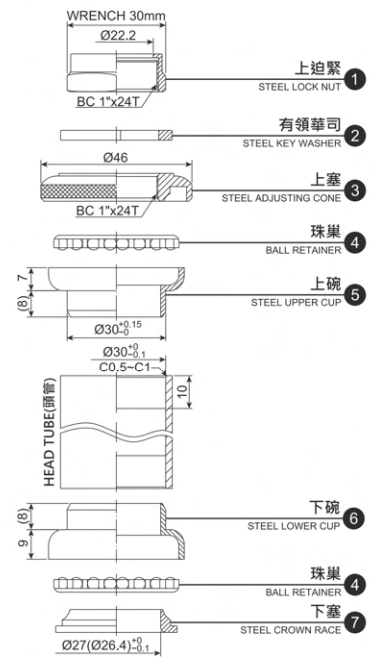

堆積高度 (STACK HEIGHT) = 36 ± 1 mm

H802AK



WEIGHT

150g

SIZE

1"x24T

DIMENSIONS

Ø21.1x32.5x27

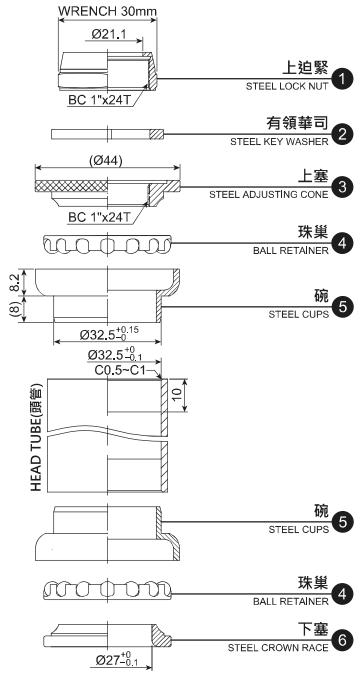

堆積高度 (STACK HEIGHT) = 36 ± 1 mm

H806



WEIGHT

144.7g

SIZE

1"x24T

DIMENSIONS

Ø22.2x30x27(26.4)

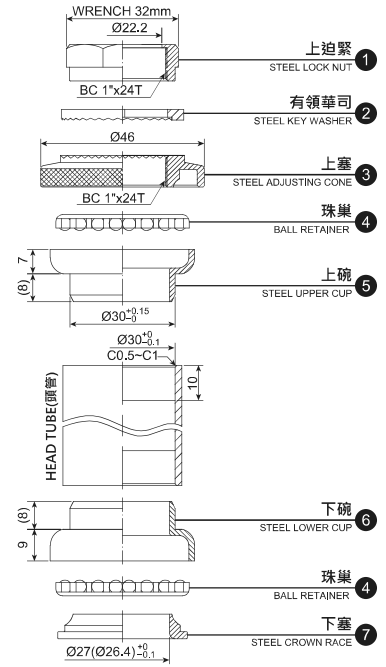

堆積高度 (STACK HEIGHT) = 35 ± 1 mm

H807W



WEIGHT

115g

SIZE

1"x24T

DIMENSIONS

Ø22.2x30x27(26.4)

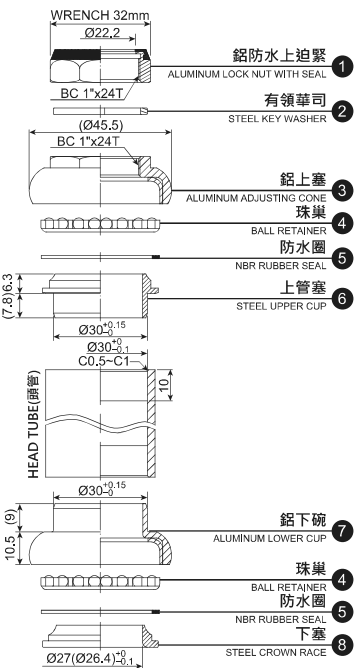

堆積高度 (STACK HEIGHT) = 39.5 ± 1 mm

H815W



WEIGHT

145g

SIZE

1-1/8"x26T

DIMENSIONS

Ø25.4x34x30

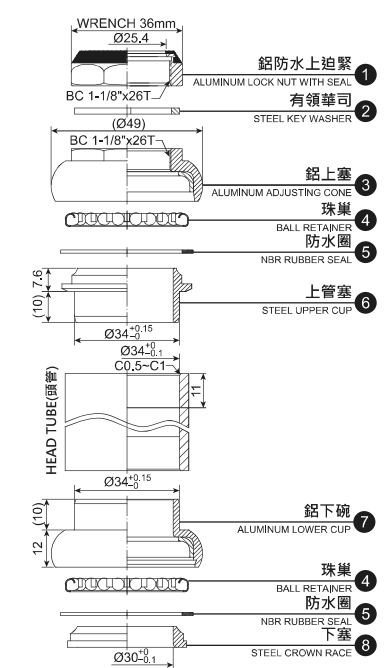

堆積高度 (STACK HEIGHT) = 43 ± 1 mm

NECO EXTERNAL CUP THREADED HEADSETS

外露式有牙車頭碗 EXTERNAL CUP THREADED HEADSETS

H831



WEIGHT

134g

SIZE

1"x24T

DIMENSIONS

Ø22.2x30x27(26.4)

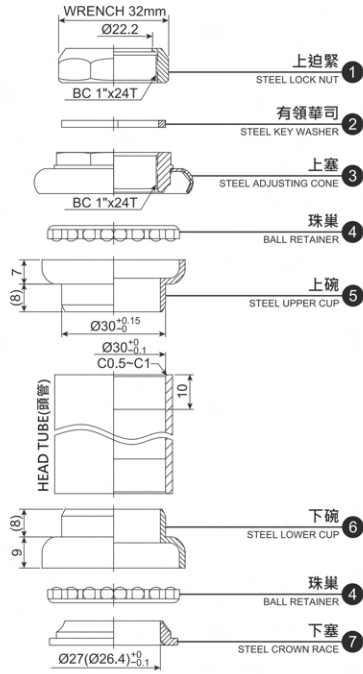

堆積高度 (STACK HEIGHT) = 36.5 ± 1 mm

H831CW



WEIGHT

140.1g

SIZE

1"x24T

DIMENSIONS

Ø22.2x30x27(26.4)

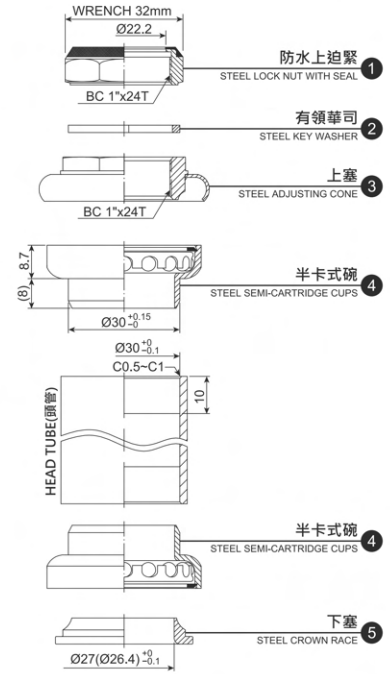

堆積高度 (STACK HEIGHT) = 36.5 ± 1 mm

H831SW



WEIGHT

134g

SIZE

1"x24T

DIMENSIONS

Ø22.2x30x27(26.4)

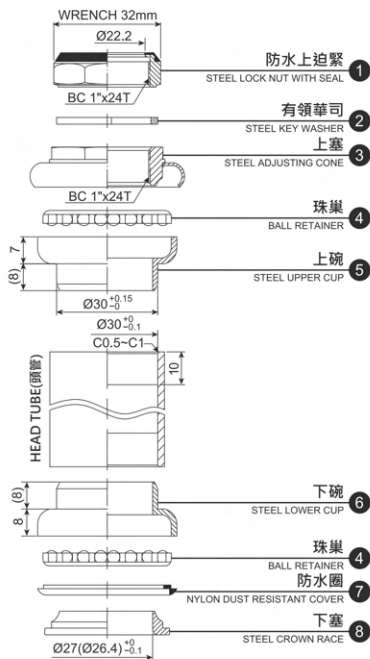

堆積高度 (STACK HEIGHT) = 36.5 ± 1 mm

H833K



WEIGHT

127.8g

SIZE

1-1/8"Head Tube
Reduced to 1" Fork
Tube Threaded
Headset

DIMENSIONS

Ø22.2x34/27(26.4)

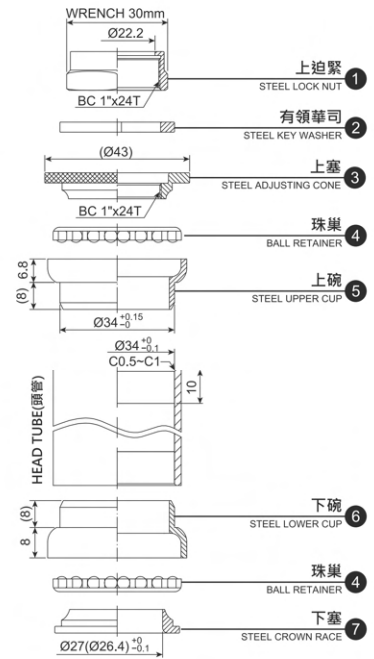

堆積高度 (STACK HEIGHT) = 33.5 ± 1 mm

H834SW



WEIGHT

139.4g

SIZE

1-1/8"Head Tube
Reduced to
1" Fork Tube
Threaded Headset

DIMENSIONS

Ø22.2x34x27(26.4)

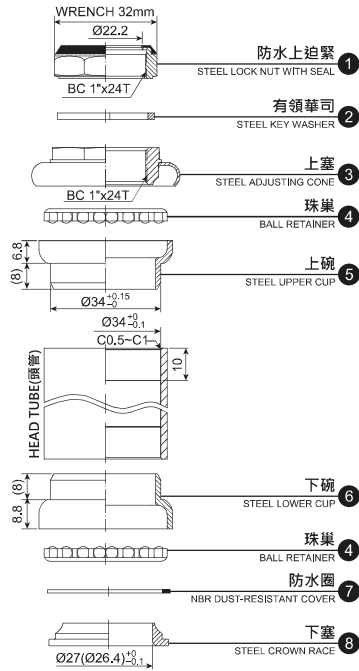

堆積高度 (STACK HEIGHT) = 36 ±1 mm

H841G



WEIGHT

160.2g

SIZE

1-1/8"x26T

DIMENSIONS

Ø28.6x34x30

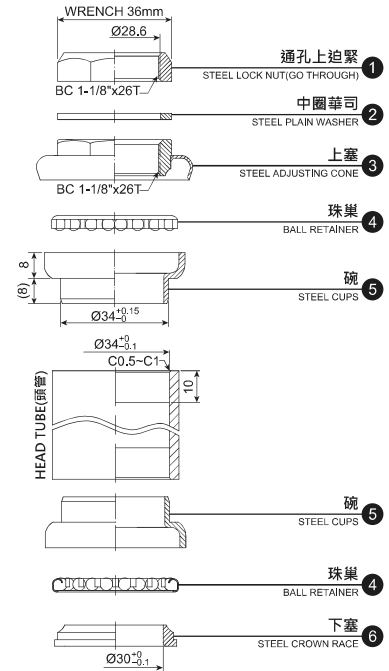

堆積高度 (STACK HEIGHT) = 37.5 ±1 mm

H841CW



WEIGHT

171.4g

SIZE

1-1/8"x26T

DIMENSIONS

Ø25.4x34x30

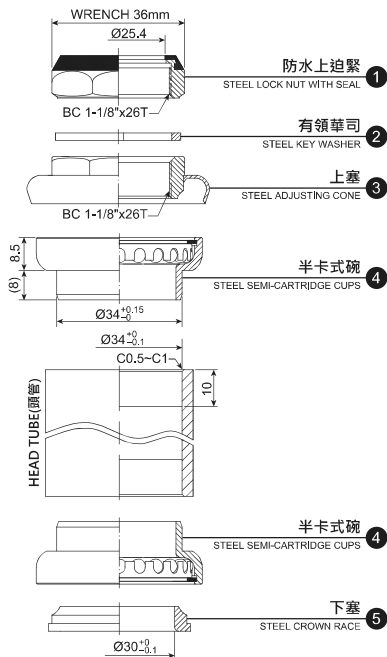

堆積高度 (STACK HEIGHT) = 38 ±1 mm

H841SW



WEIGHT

161g

SIZE

1-1/8"x26T

DIMENSIONS

Ø25.4x34x30

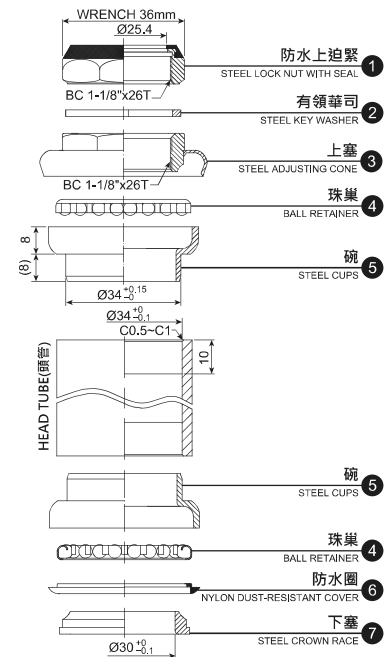

堆積高度 (STACK HEIGHT) = 37.5 ±1 mm

NECO EXTERNAL CUP THREADED HEADSETS

外露式有牙車頭碗 EXTERNAL CUP THREADED HEADSETS

H841SW-P



WEIGHT

174g

SIZE

1-1/8"x26T

DIMENSIONS

Ø25.4x34x30

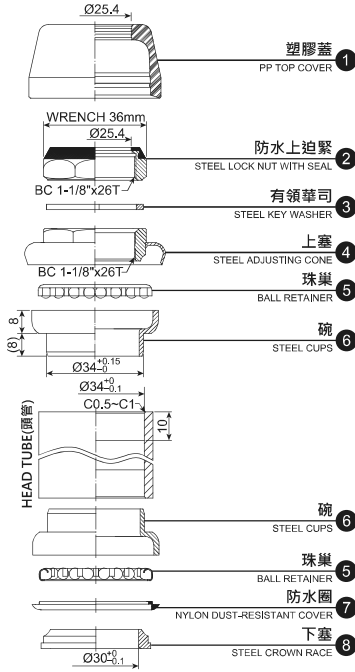

堆積高度 (STACK HEIGHT) = 37.5 ± 1 mm

H842-2



WEIGHT

190g

SIZE

1-1/8"x26T

DIMENSIONS

Ø25.4x34x30

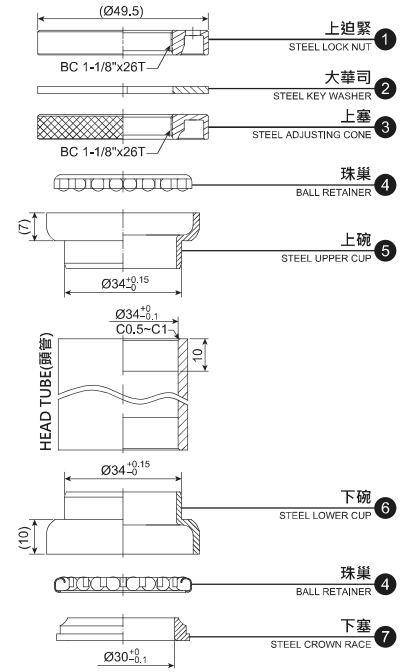

堆積高度 (STACK HEIGHT) = 30.5 ± 1 mm

H842SW



WEIGHT

149g

SIZE

1-1/8"x26T

DIMENSIONS

Ø25.4x34x30

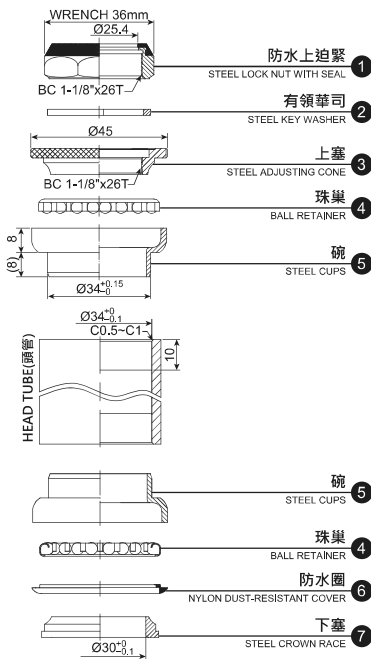

堆積高度 (STACK HEIGHT) = 34 ± 1 mm

H843NW



WEIGHT

188g

SIZE

1-1/8"x26T

DIMENSIONS

Ø25.4x34x30

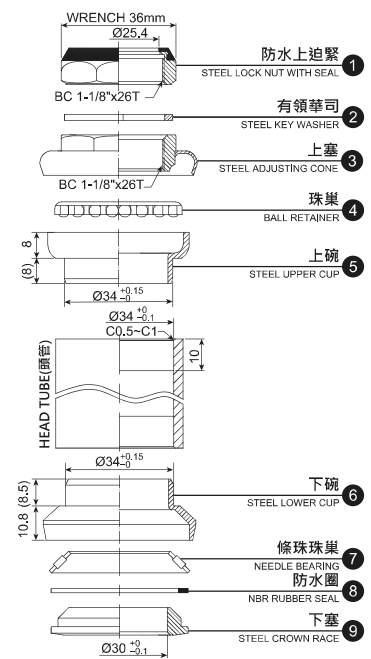

堆積高度 (STACK HEIGHT) = 39 ± 1 mm

HE8001

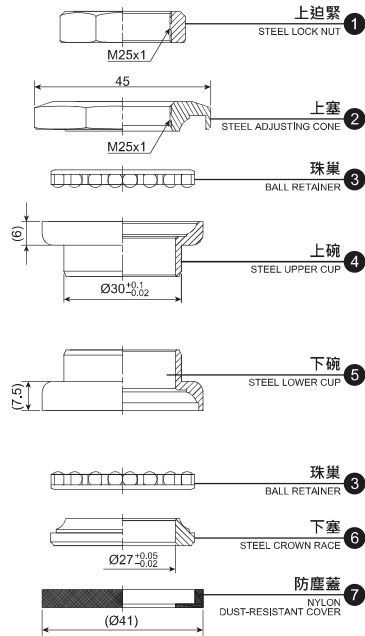
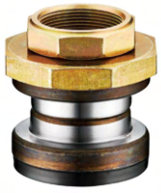

HE8002

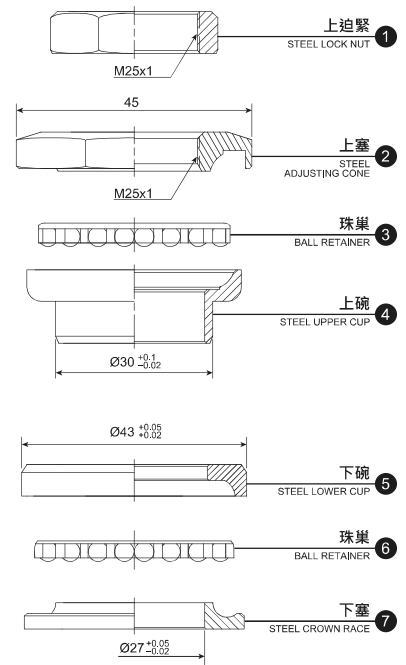
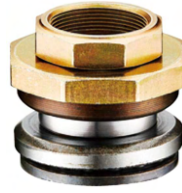

HE8003

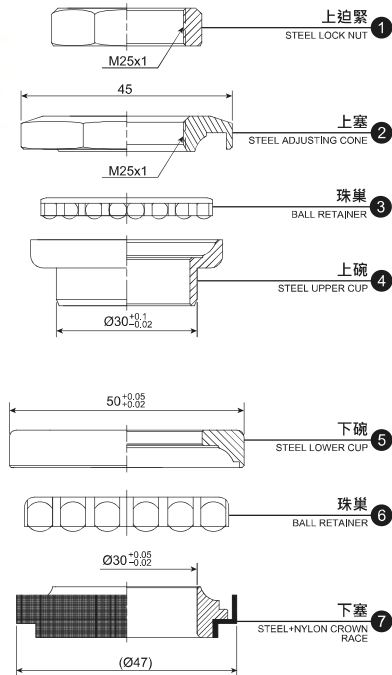
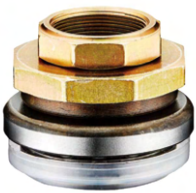

ACCESSORIES

配件



NECO



H361 ALLOY COVER

HEIGHT 高度	31mm
WEIGHT 重量	31g
FINISH 表面處理	Silver,BK
	Aluminum Cover for 1-1/8"
SIZE 尺寸	Threaded Headset
DIMENSIONS 孔徑	Φ25.4



H361H ALLOY COVER

HEIGHT 高度	31mm
WEIGHT 重量	35.5g
FINISH 表面處理	Silver,BK
	Aluminum Cover for 1-1/8"
SIZE 尺寸	Threaded Headset
DIMENSIONS 孔徑	Φ25.4



H128 ALLOY COVER

HEIGHT 高度	27.4mm
WEIGHT 重量	19g
FINISH 表面處理	Silver,BK
	Aluminum Cover for 1-1/8"
SIZE 尺寸	Threaded Headset
DIMENSIONS 孔徑	Φ25.4
OPTIONAL 可選配: H127(1") ALLOY COVER	Size:Aluminum Cover for 1"Threaded Headset Dimensions:Φ22.2



H128H(1-1/8") ALLOY COVER

HEIGHT 高度	27.4mm
WEIGHT 重量	19g
FINISH 表面處理	Silver,BK
	Aluminum Cover for 1-1/8"
SIZE 尺寸	Threaded Headset
DIMENSIONS 孔徑	Φ25.4 Machined Window for Front Bracket
OPTIONAL 可選配: H127H(1") ALLOY COVER	Size:Aluminum Cover for 1"Threaded Headset Dimensions:Φ22.2



H128 PLASTIC COVER

HEIGHT 高度	26.4mm
WEIGHT 重量	11.2g
FINISH 表面處理	BK
SIZE 尺寸	Plastic Cover for 1-1/8"Threaded Headset
DIMENSIONS 孔徑	Φ25.4
OPTIONAL 可選配: H831(1") PLASTIC COVER	Size:Plastic Cover for 1"Threaded headset Dimensions:Φ22.2



H138P

HEIGHT 高度	27.4mm
WEIGHT 重量	15.8g
FINISH 表面處理	BK
SIZE 尺寸	Plastic Cover For 1.5"Threaded headset
DIMENSIONS 孔徑	Φ25.4



C286G/C254G

FINISH	表面處理	Silver,Black 銀/黑
SIZE	尺寸	1-1/8"
		Aluminum Top Cap 鋁頂蓋
COMPONENT	內容物	Aluminum Body 鋁本體
FORK TUBE ID	立管內徑	Ø22-Ø25.4
DEPTH OF BODY	本體長	18mm
		C254G Size: 1"
OPTIONAL	可選配	Fork Tube ID 頭管內徑:20-22.2mm
WEIGHT	重量	C286G:42g,C254G:39.4g



C286GC/C254GC

FINISH	表面處理	Carbon Fiber 碳纖維
SIZE	尺寸	1-1/8"
		Carbon Top Cap 碳纖維頂蓋
COMPONENT	內容物	Aluminum Body 鋁本體
FORK TUBE ID	立管內徑	Ø22-Ø25.4
DEPTH OF BODY	本體長	18mm
		C254GC Size: 1"
OPTIONAL	可選配	Fork Tube ID 立管內徑:20-22.2mm
WEIGHT	重量	C286GC:38.6g,C254GC:35g



C286GX/C254GX

FINISH	表面處理	Silver,Black 銀/黑
SIZE	尺寸	1-1/8"
		Aluminum Top Cap 鋁頂蓋
COMPONENT	內容物	Aluminum Body 鋁本體
FORK TUBE ID	立管內徑	Ø22-Ø25.4
DEPTH OF BODY	本體長	32mm
		C254GX Size:1"
OPTIONAL	可選配	Fork Tube ID 立管內徑:20-22.2mm
WEIGHT	重量	C286GX:50.9g,C254GX:44.7g



C286GCX/C254GCX

FINISH	表面處理	Carbon Fiber 碳纖維
SIZE	尺寸	1-1/8"
		Carbon Top Cap 碳纖維頂蓋
COMPONENT	內容物	Aluminum Body 鋁本體
FORK TUBE ID	立管內徑	Ø22-Ø25.4
DEPTH OF BODY	本體長	32mm
		C254GCX Size:1"
OPTIONAL	可選配	Fork Tube ID 立管內徑:20-22.2mm
WEIGHT	重量	C286GCX:47.5g,C254GCX:39.3g



C286GL

FINISH	表面處理	Silver, Black 銀/黑
SIZE	尺寸	1-1/8"
		Aluminum Top Cap 鋁頂蓋
COMPONENT	內容物	Aluminum Body 鋁本體
FORK TUBE ID	立管內徑	Ø22-Ø25.4
DEPTH OF BODY	本體長	52mm
WEIGHT	重量	64.3g



C286GCL

FINISH	表面處理	Carbon Fiber 碳纖維
SIZE	尺寸	1-1/8"
		Carbon Top Cap 碳纖維頂蓋
COMPONENT	內容物	Aluminum Body 鋁本體
FORK TUBE ID	立管內徑	Ø22-Ø25.4
DEPTH OF BODY	本體長	52mm
WEIGHT	重量	61.4g



C2861/C2541

FINISH 表面處理	Silver, Black 銀/黑
SIZE 尺寸	1-1/8"
Aluminum Top Cap 鋁頂蓋 Star Washer 碟片 Steel or Stainless Bolt 鐵或白鐵螺絲 鐵或白鐵螺絲	
COMPONENT 內容物	M6xP1.0x30L
OPTIONAL 可選配	C2541 Size: 1"
WEIGHT 重量	C2861:24.6g C2541:23.5g



C2861DC

FINISH 表面處理	Two Tone Color雙色
SIZE 尺寸	1-1/8"
Aluminum Top Cap 鋁頂蓋 Star Washer 碟片 Steel or Stainless Bolt 鐵或白鐵螺絲 鐵或白鐵螺絲	
COMPONENT 內容物	M6xP1.0x30L
WEIGHT 重量	23.7g



C2861C/C2541C

FINISH 表面處理	Carbon Fiber 碳纖維
SIZE 尺寸	1-1/8"
Carbon Top Cap 碳纖維頂蓋 Star Washer 碟片 Stainless Bolt 白鐵螺絲 鐵或白鐵螺絲	
COMPONENT 內容物	M6xP1.0x30L
OPTIONAL 可選配	C2541C Size: 1"
WEIGHT 重量	C2861C:21.5g C2541C:20.5g



C2869/C2549

FINISH 表面處理	Silver, Black 銀/黑
SIZE 尺寸	1-1/8"
Aluminum Top Cap 鋁頂蓋 Star Washer 碟片 Steel Hollow Bolt 鐵空心螺絲 M10xP1.25	
COMPONENT 內容物	
FORK TUBE 立管外徑內徑	Ø28.6/Ø25.4
OPTIONAL 可選配	C2549 Size: 1"
WEIGHT 重量	C2869:37.9g ; C2549:36.3g



C2861TT/C2861TS

FINISH 表面處理	Silver, Black 銀/黑
SIZE 尺寸	1-1/8"
Aluminum Top Cap 鋁頂蓋 Star Washer 碟片 Stainless Bolt 白鐵螺絲 M6xP1.0x30L	
COMPONENT 內容物	
OPTIONAL 可選配	C2861TT:34mm C2861TS:32mm
WEIGHT 重量	C2861TT:29.4g C2861TS:28.9g



C2862D/C2542D

FINISH 表面處理	Silver, Black 銀/黑
SIZE 尺寸	1-1/8"
Aluminum Top Cap 鋁頂蓋 Star Washer 碟片 Steel or Stainless Bolt 鐵或白鐵螺絲 鐵或白鐵螺絲	
COMPONENT 內容物	M6xP1.0x30L
OPTIONAL 可選配	C2542D Size: 1"
WEIGHT 重量	C2862D 22.4g C2542D:21.4g



C371

FINISH 表面處理	Silver, Black 銀/黑
SIZE 尺寸	1-1/8"
Aluminum Top Cap 鋁頂蓋 Star Washer 碟片 Steel or Stainless Bolt 鐵或白鐵螺絲 鐵或白鐵螺絲	
COMPONENT 內容物	M6xP1.0x30L
FORK TUBE 立管外徑內徑	Ø28.6/Ø25.4
WEIGHT 重量	24g



C2870

FINISH 表面處理	Silver, Black 銀/黑
SIZE 尺寸	1-1/8"
Aluminum Top Cap 鋁頂蓋 Star Washer 碟片 Stainless Bolt 白鐵螺絲 M6xP1.0x30L	
COMPONENT 內容物	
FORK TUBE 立管外徑內徑	Ø28.6/Ø25.4
WEIGHT 重量	22.1g



C371F

FINISH 表面處理	Silver, Black 銀/黑
SIZE 尺寸	1-1/8"
Aluminum Top Cap 鋁頂蓋 Star Washer 碟片 Steel or Stainless Bolt 鐵或白鐵螺絲 鐵或白鐵螺絲	
COMPONENT 內容物	M6xP1.0x30L
FORK TUBE 立管外徑內徑	Ø28.6/Ø25.4
WEIGHT 重量	27g



ALLOY SPACER-CC

MATERIAL	材質	Aluminum鋁
FORK TUBE O.D.	立管外徑	1-1/8"(28.6mm)
SPACER O.D.	墊片外徑	34mm
DEPTH OF BODY	厚度	2.5/5/10/15/20mm



ALLOY SPACER

MATERIAL	材質	Aluminum鋁
FORK TUBE O.D.	立管外徑	1-1/8"(28.6mm)/1"(25.4mm)
SPACER O.D.	墊片外徑	36mm(1-1/8")/32mm(1")
DEPTH OF BODY	厚度	2/5/8/10/15/20mm



C203

INNER & OUTER EXPANDER

FINISH	表面處理	Silver,Black 銀/黑
SIZE	尺寸	1-1/8"
COMPONENT	內容物	Aluminum Top Cap 鋁頂蓋 Expander Bolt 加長型螺絲 M6xP1.0x200L



ALLOY SPACER-R

ALLOY SPACERS WITH RADIUS OUTER LOOK

MATERIAL	材質	Aluminum鋁
FORK TUBE O.D.	立管外徑	1-1/8"(28.6mm)/1"(25.4mm)
SPACER O.D.	墊片外徑	36mm(1-1/8")/32mm(1")
DEPTH OF BODY	厚度	5/10/15/20mm



CARBON SPACER

MATERIAL	材質	Carbon Fiber 碳纖維
FORK TUBE O.D.	立管外徑	1-1/8"(28.6mm)/1"(25.4mm)
SPACER O.D.	墊片外徑	35mm(1-1/8")/31mm(1")
DEPTH OF BODY	厚度	3/5/8/10/15/20mm



C204

INNER & OUTER EXPANDER

FINISH	表面處理	Silver,Black 銀/黑
SIZE	尺寸	1-1/8"
COMPONENT	內容物	Aluminum Top Cap 鋁頂蓋 Expander Bolt 加長型螺絲 M6xP1.0x200L

286G 系列組拆裝說明

Assembly of Tension Adjust

Assembling description, please see the illustration as below:

1. Put the fixer of Tension Adjust (T.A.) on the steer. see fig. 1.
2. Use the allen key(6mm) to screw in allen bolt tight to be very firmly. (recommended torque about 7~10N.m;72~102kgf-cm) see fig. 2.
3. Put the stem on the steer. see fig. 3.
4. Put the alloy cap of T.A. on the stem. see fig. 4.
5. Use the allen key to screw in the bolt of alloy cap tight. (recommended torque about 5~8N.m;51~82kgf-cm) see fig. 5.
6. Use the allen key to screw in the bolts of stem tight to be very firmly, see fig. 6. (if enclosed with rubber cover, place the rubber cap in the allen bolt.)

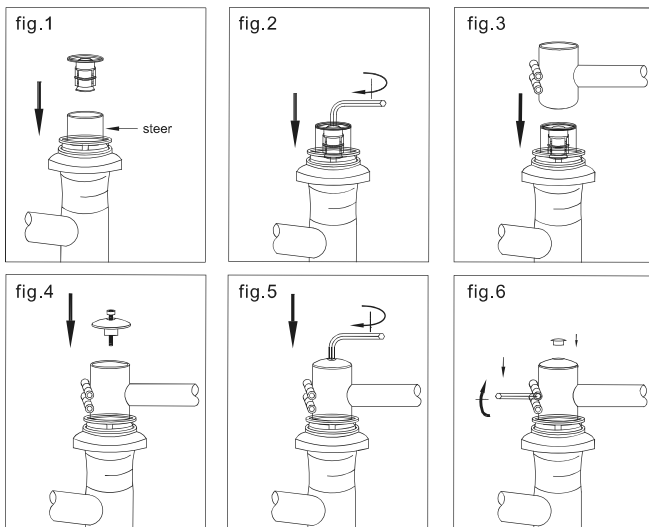

Disassembly of Tension Adjust

Disassembling description, please see the illustration as below:

1. (If enclosed with rubber cover, remove the rubber cap from the allen bolt.) Use the allen key to unscrew the bolt of alloy cap. see fig. 1, and take it out. see fig. 2.
2. Use the allen key to unscrew the bolts of stem. see fig. 3, and take it out. see fig.4.
3. Use the allen key(6mm) to unscrew the fixer of T.A. until it is about 3mm above the steer. see fig. 5. Then use your palm to hit lightly until it come off the steer, and take it out. see fig. 6.

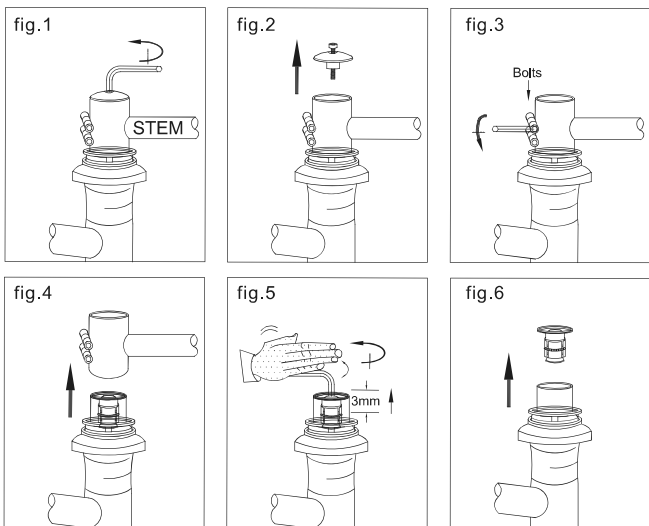

Warning: Always ensure all bolts are secured tightly before riding. If you are unclear about the installation and adjustment of this product, your headset or stem, see your professional bicycle dealer for advice. If you have questions about threadless headset assembling instruction please contact your local dealers.

上迫緊器組裝方法

請見以下組裝說明:

1. 將下迫緊件放入前叉豎管內,如fig.1.
2. 使用內六角扳手(6mm)將下迫緊件鎖緊至適當鬆緊度。(建議扭力約7~10N.m;72~102kgf-cm)如fig.2.
3. 放入車手立管,如fig.3.
4. 放入上迫緊件(鋁蓋+螺絲),如fig.4.
5. 使用內六角扳手將上迫緊件鎖緊至適當鬆緊度(建議扭力約5~8N.m;51~82kgf-cm)如fig.5.
6. 使用內六角扳手將車手立管上螺絲 緊至適當鬆緊度,如fig.6.(若有附上橡膠上蓋,則將橡膠上蓋壓入螺絲六角孔內.)

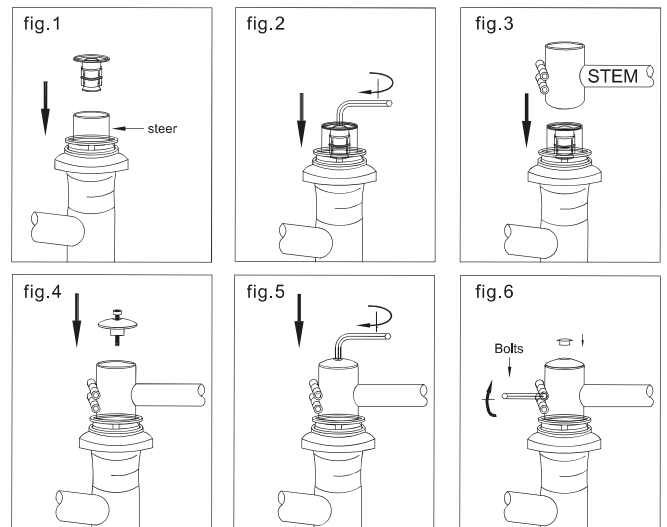

上迫緊器拆卸方法

請見以下拆卸說明:

1. (若有附上橡膠上蓋,則將橡膠上蓋自螺絲六角孔內取出。)使用內六角扳手將上迫緊件上的螺絲放鬆,如fig.1,然後將上迫緊件取出如fig.2.
2. 使用內六角扳手將車手立管上螺絲放鬆,如fig.3,然後將手立管取出,如fig.4。(如果前叉不換時,可不執行第三步驟)
3. 使用內六角扳手(6mm)將下迫緊件放鬆,直到下迫緊器上移為3mm(相對於前叉立管的高度),如fig.5,然後用手掌拍打下緊迫件,直到整個下緊迫件不再緊貼前叉豎管,然後取出,如fig.6.

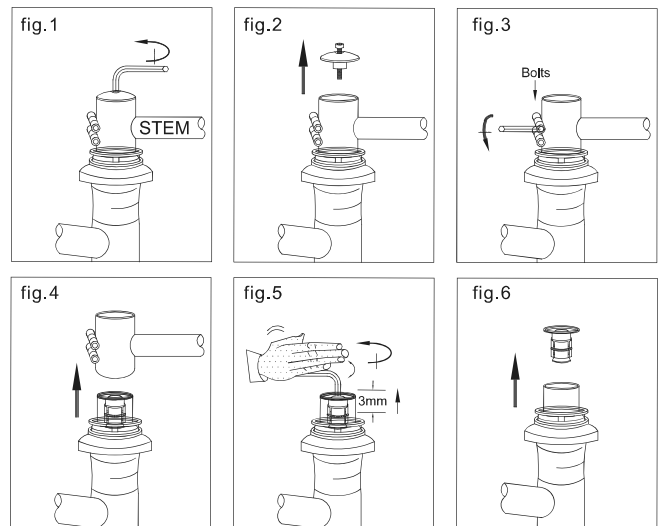

注意事項: 騎行前請注意所有螺絲件是否有鎖緊,若你不是很了解產品的組裝或調整方式包括你的車頭碗組及車手立管,請洽專業的自行車店給予協助。對於組裝說明有任何疑問或問題,請洽詢專業的自行車店提供協助。

BOTTOM BRACKET B.B. 五通碗組



NECO

外牙中軸
Nut Type Cotterless Axle

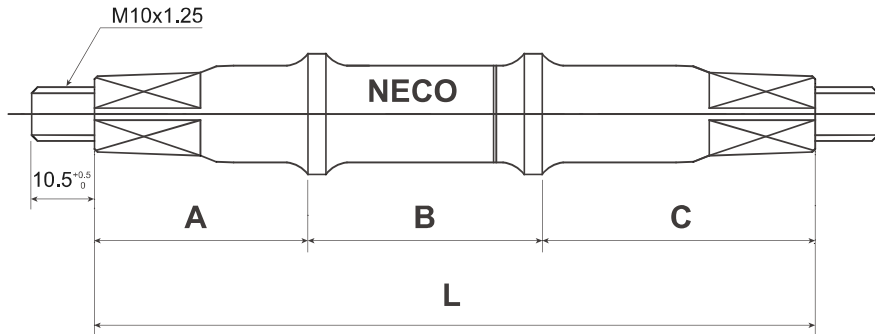

內牙中軸
Bolt Type Cotterless Axle

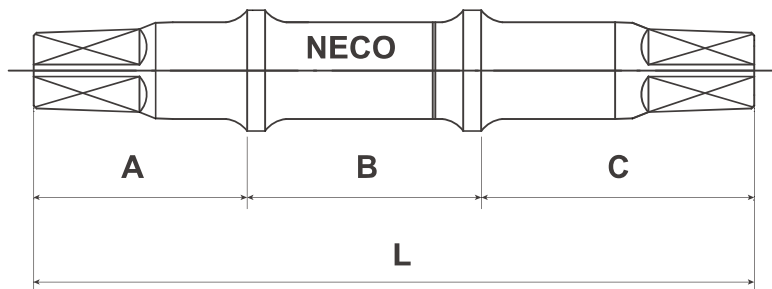

內外牙中軸尺寸圖
Bolt/Nut Type Axle Dimension Chart

AXLE MODEL	3H	3E	3M	3J	3L	3A	3P	3PL	3N	3NL	3SS	3S	3T	3U	3UM	3R	3RM	3RMC	3MC
BRACKET WIDTH	68	68	68	68	68	68	68	68	68	68	68	68	68	68	68	68	68	68	68
A	28	28	29	30.5	32	32	32	35	32	35	32	35	35	35	37.5	35	37.5	40.5	32
B	52	52	52	52	52	52	52	52	52	52	52	52	52	52	52	52	52	52	52
C	28	30.5	29	30.5	32	33.5	35	35	36	36	37.5	37.5	39	40.5	40.5	42	42	42	43.5
L	108.0	110.5	110	113	116	117.5	119	122	120	123.0	121.5	124.5	126	127.5	130	129	131.5	134.5	127.5

AXLE MODEL	5A	5P	5SS	5S	5T	5U	5R	7J	7L	7A	7P	7PL	7N	7NN	7SS	7S	7T	7U	7R
BRACKET WIDTH	70	70	70	70	70	70	70	73	73	73	73	73	73	73	73	73	73	73	73
A	32	32	32	35	35	35	35	30.5	32	32	32	35	32	36	32	35	35	35	35
B	54	54	54	54	54	54	54	57	57	57	57	57	57	57	57	57	57	57	57
C	33.5	35	37.5	37.5	39	40.5	42	30.5	32	33.5	35	35	36	36	37.5	37.5	39	40.5	42
L	119.5	121.0	123.5	126.5	128	129.5	131	118	121	122.5	124	127	125	129	126.5	129.5	131	132.5	134

PS:橘字尺寸有最低訂購量限制。Orange Number Dimension, have MOQ limit.

B906 / (B906E) / (B906B)



12.65±0.05

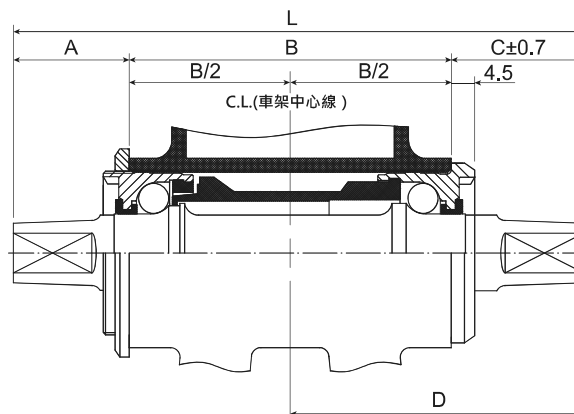
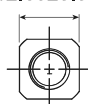

COMPONENTS	內容物	
LOCKING RING COLOR	鎖環顏色	Black 黑
CUP COLOR	碗顏色	Black 黑
APPLICATIONS	適合車種	MTB 登山車, Road 公路車
WEIGHT(LENGTH122.5)	重量(長度122.5)	B906/315g

Threads	牙紋規格	
Steel cups	鐵左右碗	B906/B906B
E-type steel cup	鐵左右碗, 右碗為 E-type	E-type(B906E)

AXLE MODEL 中軸代號	AXLE LENGTH 中軸長度	B.B. SHELL WIDTH=68mm 五通管寬度 68mm				B.B. SHELL WIDTH=70mm 五通管寬度 70mm			
		L	A	B	C	D	A	B	C
2H	108.0(29.0/50/29.0)	20.5	68	19.5	53.5	18.5	70	19.5	54.5
2M	111.0(30.5/50/30.5)	22.0	68	21.0	55.0	20.0	70	21.0	56.0
2J	113.5(31.5/50/32.0)	23.0	68	22.5	56.5	21.0	70	22.5	57.5
2L	116.0(33.0/50/33.0)	24.5	68	23.5	57.5	22.5	70	23.5	58.5
2A	118.0(33.0/50/35.0)	24.5	68	25.5	59.5	22.5	70	25.5	60.5
2P	119.0(33.0/50/36.0)	24.5	68	26.5	60.5	22.5	70	26.5	61.5
2N	120.5(33.0/50/37.5)	24.5	68	28.0	62.0	22.5	70	28.0	63.0
2SS	122.0(33.0/50/39.0)	24.5	68	29.5	63.5	22.5	70	29.5	64.5
2NL	122.5(35.0/50/37.5)	26.5	68	28.0	62.0	24.5	70	28.0	63.0
2S	125.0(36.0/50/39.0)	27.5	68	29.5	63.5	25.5	70	29.5	64.5
2T	126.5(36.0/50/40.5)	27.5	68	31.0	65.0	25.5	70	31.0	66.0
2U	128.0(36.0/50/42.0)	27.5	68	32.5	66.5	25.5	70	32.5	67.5
2R	129.5(36.0/50/43.5)	27.5	68	34.0	68.0	25.5	70	34.0	69.0
2UM	131.0(39.0/50/42.0)	30.5	68	32.5	66.5	28.5	70	32.5	67.5
2RMC	135.5(42.0/50/43.5)	33.5	68	34.0	68.0	31.5	70	34.0	69.0

PS:橘字尺寸有最低訂購量限制。Orange Number Dimension, have MOQ limit.

B910/(B910E)/(B910P)/(B910B)/ (B910PP)/(B910T)/(B910TE)/(B910PPT)

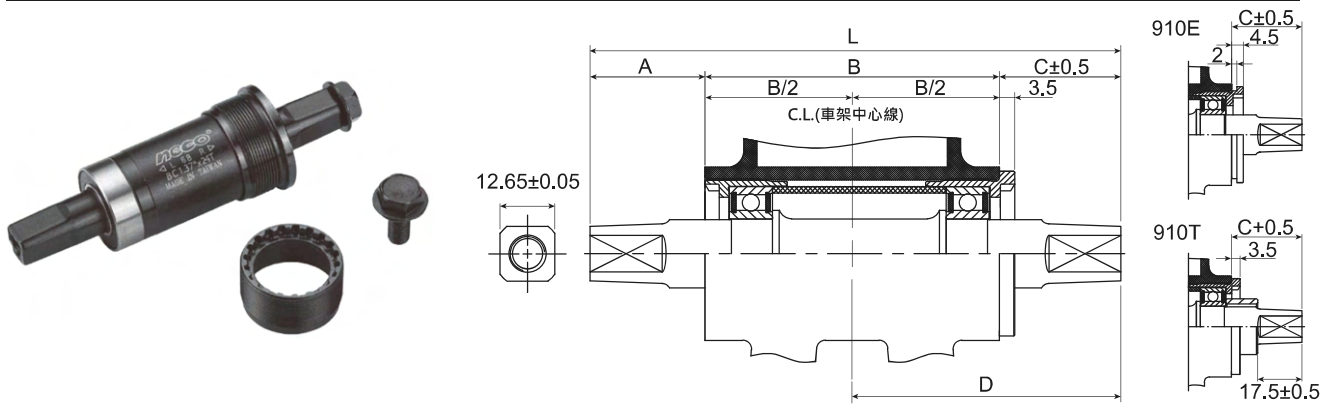

COMPONENTS	內容物	10B21 Spindle & Steel cups, Steel Body, Sealed Bearing 2pcs 鐵軸心, 鐵牙碗, 鐵中管, 培林x2
CUP COLOR	碗顏色	Black 黑
APPLICATIONS	適合車種	MTB 登山車, Road 公路車
WEIGHT(LENGTH122.5)	重量(長度122.5)	B910/312.6g, B910P/292g, B910PP/266g
Threads	牙紋規格	BC 1.37"x24T R/L(B910/B910E/B910P/B910PP) BC 36mmx24T R/R(B910B)
Steel cups	鐵左右碗	B910/B910B
Steel right cup & nylon left cup	鐵右碗, 塑鋼左碗	B910P
Nylon cups	塑鋼左右碗	B910PP
E-type steel cup	鐵左右碗, 右碗為 E-type	B910E
Alloy tube	鋁檔管	B910T

LENGTH 中軸長度	B.B. SHELL WIDTH=68mm 五通管寬度 68mm				B.B. SHELL WIDTH=70mm 五通管寬度 70mm				B.B. SHELL WIDTH=73mm 五通管寬度 73mm				
	L	A	B	C	D	A	B	C	D	A	B	C	D
103.0	(16.5)	68	18.5	52.5									
107.5	(19.0)	68	20.5	54.5									
110.5	(22.0)	68	20.5	54.5	(21.0)	70	19.5	54.5					
113.5	(22.5)	68	23.0	57.0	(21.5)	70	22.0	57.0	(20.0)	73	20.5	57.0	
115.0	(23.0)	68	24.0	58.0	(22.0)	70	23.0	58.0	(20.5)	73	21.5	58.0	
116.0	(23.0)	68	25.0	59.0	(22.0)	70	24.0	59.0	(20.5)	73	22.5	59.0	
118.0	(25.0)	68	25.0	59.0	(24.0)	70	24.0	59.0	(22.5)	73	22.5	59.0	
119.0	(24.0)	68	27.0	61.0	(23.0)	70	26.0	61.0	(21.5)	73	24.5	61.0	
122.5	(26.0)	68	28.5	62.5	(25.0)	70	27.5	62.5	(23.5)	73	26.0	62.5	
124.5	(27.0)	68	29.5	63.5	(26.0)	70	28.5	63.5	(24.5)	73	27.0	63.5	
126.0	(27.0)	68	31.0	65.0	(26.0)	70	30.0	65.0	(24.5)	73	28.5	65.0	
127.5	(28.5)	68	31.0	65.0	(27.5)	70	30.0	65.0	(26.0)	73	28.5	65.0	
131.0	(29.0)	68	34.0	68.0	(28.0)	70	33.0	68.0	(26.5)	73	31.5	68.0	
134.0	(30.0)	68	36.0	70.0	(29.0)	70	35.0	70.0	(27.5)	73	33.5	70.0	
147.0	(36.0)	68	41.0	75.0									

PS:橘字尺寸有最低訂購量限制。Orange Number Dimension, have MOQ limit.

B910NT

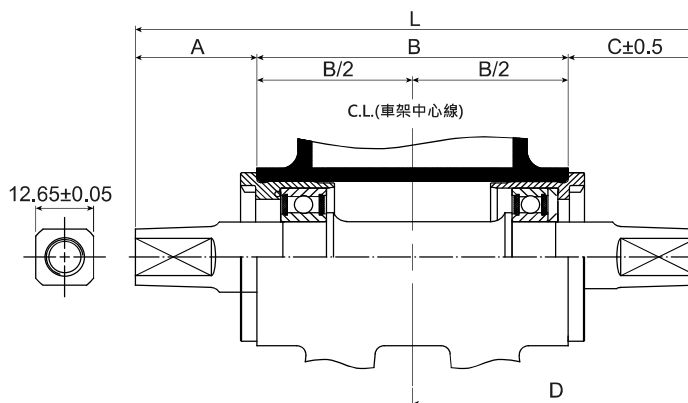

COMPONENTS	內容物	10B21 Spindle & Nylon cups Sealed Bearing 2pcs 鐵軸心 塑鋼牙碗, 培林x2
CUP COLOR	碗顏色	Black 黑
APPLICATIONS	適合車種	MTB登山車, Road公路車
Threads	牙紋規格	BC 1.37"x24T R/L

LENGTH 中軸長度	B.B. SHELL WIDTH=68mm 五通管寬度 68mm				B.B. SHELL WIDTH=70mm 五通管寬度 70mm				B.B. SHELL WIDTH=73mm 五通管寬度 73mm				
	L	A	B	C	D	A	B	C	D	A	B	C	D
107.5	(19.0)	68	20.5	54.5									
110.5	(22.0)	68	20.5	54.5	(21.0)	70	19.5	54.5					
113.5	(22.5)	68	23.0	57.0	(21.5)	70	22.0	57.0	(20.0)	73	20.5	57.0	
115.0	(23.0)	68	24.0	58.0	(22.0)	70	23.0	58.0	(20.5)	73	21.5	58.0	
116.0	(23.0)	68	25.0	59.0	(22.0)	70	24.0	59.0	(20.5)	73	22.5	59.0	
118.0	(25.0)	68	25.0	59.0	(24.0)	70	24.0	59.0	(22.5)	73	22.5	59.0	
119.0	(24.0)	68	27.0	61.0	(23.0)	70	26.0	61.0	(21.5)	73	24.5	61.0	
122.5	(26.0)	68	28.5	62.5	(25.0)	70	27.5	62.5	(23.5)	73	26.0	62.5	
124.5	(27.0)	68	29.5	63.5	(26.0)	70	28.5	63.5	(24.5)	73	27.0	63.5	
126.0	(27.0)	68	31.0	65.0	(26.0)	70	30.0	65.0	(24.5)	73	28.5	65.0	
127.5	(28.5)	68	31.0	65.0	(27.5)	70	30.0	65.0	(26.0)	73	28.5	65.0	
131.0	(29.0)	68	34.0	68.0	(28.0)	70	33.0	68.0	(26.5)	73	31.5	68.0	
134.0	(30.0)	68	36.0	70.0	(29.0)	70	35.0	70.0	(27.5)	73	33.5	70.0	
147.0	(36.0)	68	41.0	75.0									

PS:橘字尺寸有最低訂購量限制。Orange Number Dimension, have MOQ limit.

B911 / (B911E)

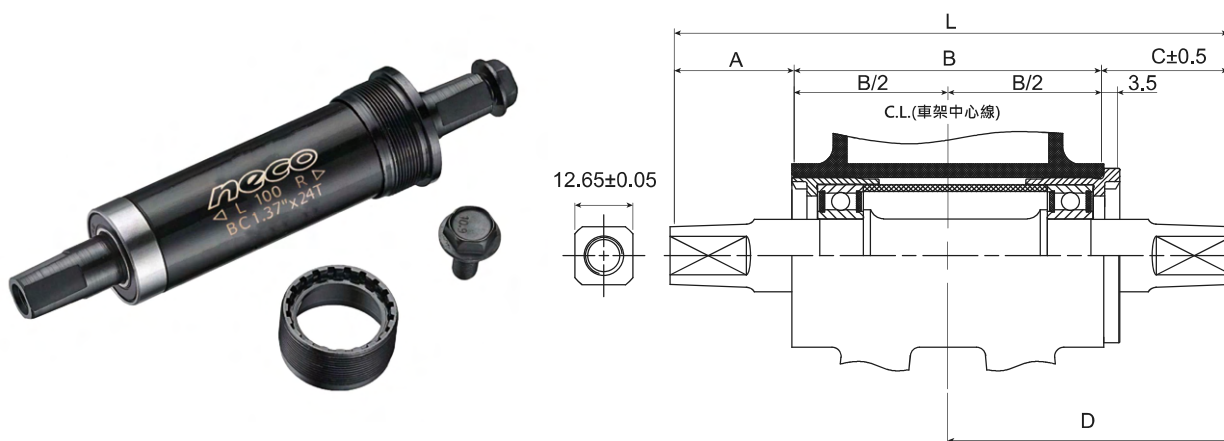

COMPONENTS	內容物	10B21 Spindle & Steel cups, Steel Body, Sealed Bearing 2pcs 鐵軸心, 鐵牙碗, 鐵中管, 培林x2
CUP COLOR	碗顏色	Black 黑
APPLICATIONS	適合車種	Fat Bike 雪地車
WEIGHT(LENGTH179.5)	重量(長度179.5)	B911/458g

Threads	牙紋規格	BC 1.37"x24T R/L
E-type steel cup	鐵左右碗, 右碗為 E-type	B911E

LENGTH 中軸長度	B.B. SHELL WIDTH=100mm 五通管寬度 100mm				B.B. SHELL WIDTH=120mm 五通管寬度 120mm				
	L	A	B	C	D	A	B	C	D
151.0	27.8	100	23.2	73.2					
159.5	30.8	100	28.7	78.7					
164.0	29.5	100	34.5	84.5					
177.0	38	100	39	89					
167.0					28.5	120	18.5	78.5	
167.0					25.0	120	22.0	82.0	
167.0					22.0	120	25.0	85.0	
179.5					30.8	120	28.7	88.7	

B920 / (B920E) / (B908) / (B920AAL) / (B920BAL)

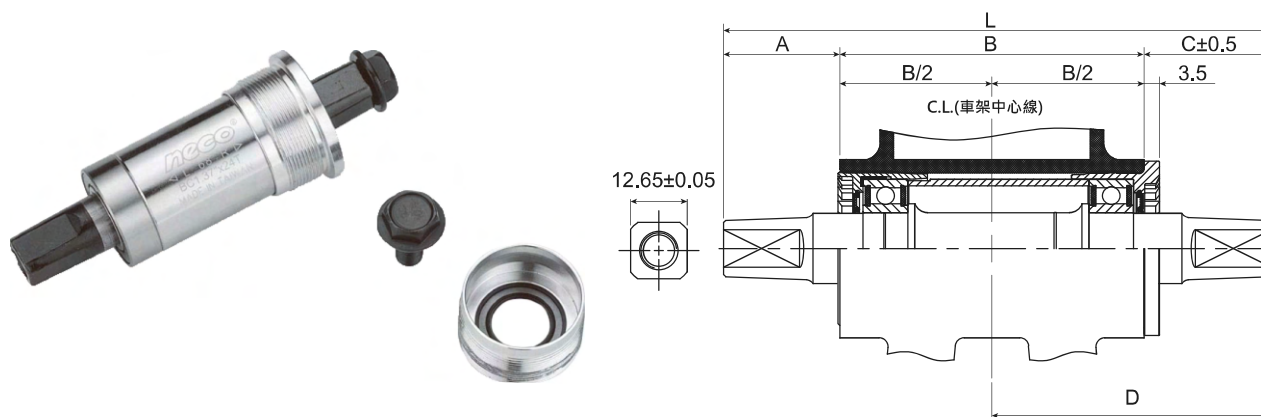

COMPONENTS	內容物	10B21 Axle & Alloy cups, Steel Body, Sealed Bearing 2pcs 鐵軸心, 鋁牙碗, 鐵中管, 培林x2
APPLICATIONS	適合車種	MTB 登山車, Road 公路車
WEIGHT(LENGTH122.5)	重量(長度122.5)	B908/310.4g, B920AL/277g, B920AAL/250g
Threads	牙紋規格	BC 1.37"x24T R/L(B920/B920E/B908/B920AAL) BC 36mmx24T R/R(B920BAL)
Alloy cups, Steel Body	鋁碗, 鐵中管	B920
Steel cups, Alloy Body	鐵碗, 鋁中管	B908
Alloy cups, Alloy Body	鋁碗, 鋁中管	B920AAL
E-type alloy cup	鋁碗, 鐵中管, 右碗為 E-type	B920E

LENGTH 中軸長度	B.B. SHELL WIDTH=68mm 五通管寬度 68mm				B.B. SHELL WIDTH=70mm 五通管寬度 70mm				B.B. SHELL WIDTH=73mm 五通管寬度 73mm				
	L	A	B	C	D	A	B	C	D	A	B	C	D
103.0	(16.5)	68	18.5	52.5									
107.5	(19.0)	68	20.5	54.5									
110.5	(22.0)	68	20.5	54.5	(21.0)	70	19.5	54.5					
113.5	(22.5)	68	23.0	57.0	(21.5)	70	22.0	57.0	(20.0)	73	20.5	57.0	
115.0	(23.0)	68	24.0	58.0	(22.0)	70	23.0	58.0	(20.5)	73	21.5	58.0	
116.0	(23.0)	68	25.0	59.0	(22.0)	70	24.0	59.0	(20.5)	73	22.5	59.0	
118.0	(25.0)	68	25.0	59.0	(24.0)	70	24.0	59.0	(22.5)	73	22.5	59.0	
119.0	(24.0)	68	27.0	61.0	(23.0)	70	26.0	61.0	(21.5)	73	24.5	61.0	
122.5	(26.0)	68	28.5	62.5	(25.0)	70	27.5	62.5	(23.5)	73	26.0	62.5	
124.5	(27.0)	68	29.5	63.5	(26.0)	70	28.5	63.5	(24.5)	73	27.0	63.5	
126.0	(27.0)	68	31.0	65.0	(26.0)	70	30.0	65.0	(24.5)	73	28.5	65.0	
127.5	(28.5)	68	31.0	65.0	(27.5)	70	30.0	65.0	(26.0)	73	28.5	65.0	
131.0	(29.0)	68	34.0	68.0	(28.0)	70	33.0	68.0	(26.5)	73	31.5	68.0	

B920HAL / (B920HBAL)

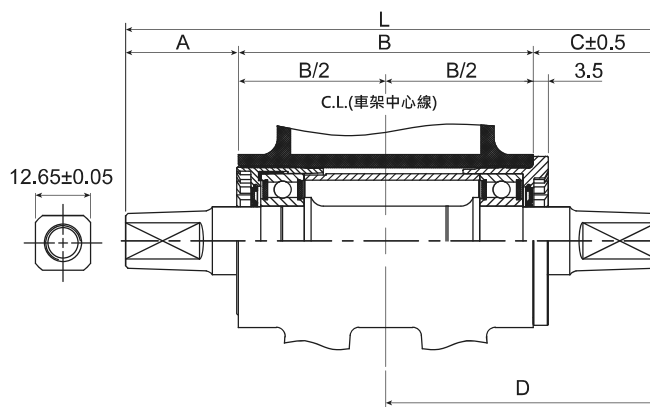

COMPONENTS	內容物	Cr-mo Stain Hollow Spindle & Alloy cups, Steel Body, Sealed Bearing 2pcs 銻鉚鋼中空軸心, 鋁牙碗, 鐵中管, 培林x2
APPLICATIONS	適合車種	Trekking Bike 旅行車, Comfort Bike 城市車
WEIGHT(LENGTH122.5)	重量(長度122.5)	B920HAL/255g
Threads	牙紋規格	BC 1.37"x24T R/L(B920HAL) BC 36mmx24T R/R(B920HBAL)

LENGTH 中軸長度	B.B. SHELL WIDTH=68mm 五通管寬度 68mm				B.B. SHELL WIDTH=70mm 五通管寬度 70mm				B.B. SHELL WIDTH=73mm 五通管寬度 73mm				
	L	A	B	C	D	A	B	C	D	A	B	C	D
107.5	(19.0)	68	20.5	54.5									
110.5	(22.0)	68	20.5	54.5	(21.0)	70	19.5	54.5					
113.5	(22.5)	68	23.0	57.0	(21.5)	70	22.0	57.0	(20.0)	73	20.5	57.0	
115.0	(23.0)	68	24.0	58.0	(22.0)	70	23.0	58.0	(20.5)	73	21.5	58.0	
116.0	(23.0)	68	25.0	59.0	(22.0)	70	24.0	59.0	(20.5)	73	22.5	59.0	
118.0	(25.0)	68	25.0	59.0	(24.0)	70	24.0	59.0	(22.5)	73	22.5	59.0	
119.0	(24.0)	68	27.0	61.0	(23.0)	70	26.0	61.0	(21.5)	73	24.5	61.0	
122.5	(26.0)	68	28.5	62.5	(25.0)	70	27.5	62.5	(23.5)	73	26.0	62.5	
127.5	(28.5)	68	31.0	65.0	(27.5)	70	30.0	65.0	(26.0)	73	28.5	65.0	
131.0	(29.0)	68	34.0	68.0	(28.0)	70	33.0	68.5	(26.5)	73	31.5	68.5	

B940 / (B940E)

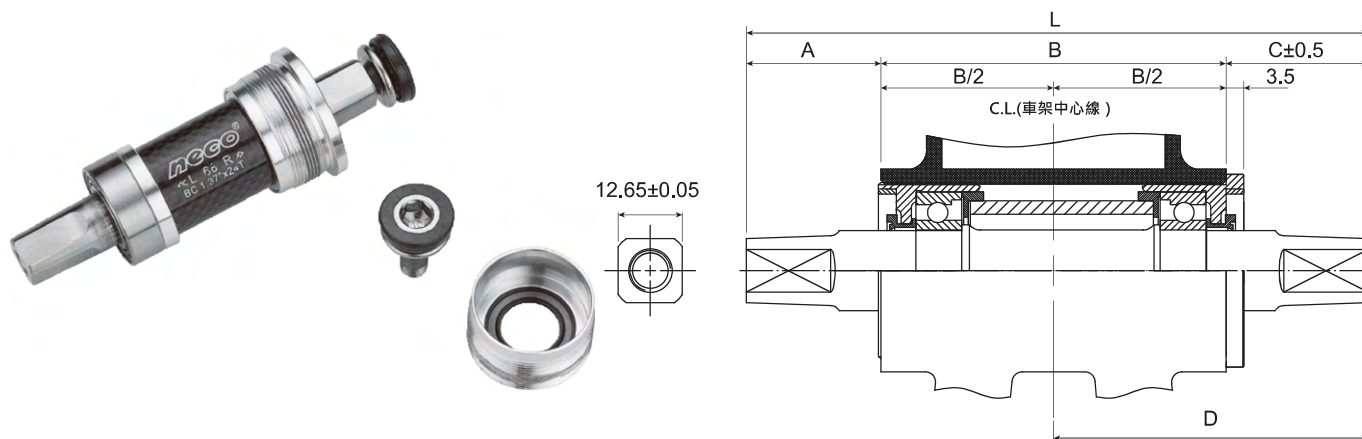

COMPONENTS	內容物	Cr-Mo Stain Hollow Spindle, Carbon Body & Alloy cups, Sealed Bearing 2pcs 鉻鉬鋼空心軸心, 碳纖維中管, 鋁碗, 培林x2
APPLICATIONS	適合車種	MTB 登山車, Road 公路車
WEIGHT(LENGTH122.5)	重量(長度122.5)	228g
Threads	牙紋規格	BC 1.37"x24T R/L
E-type alloy cup	右碗為 E-type	B940E

LENGTH 中軸長度	B.B. SHELL WIDTH=68mm 五通管寬度 68mm				B.B. SHELL WIDTH=70mm 五通管寬度 70mm				B.B. SHELL WIDTH=73mm 五通管寬度 73mm				
	L	A	B	C	D	A	B	C	D	A	B	C	D
107.5	(19.0)	68	20.5	54.5									
110.5	(22.0)	68	20.5	54.5	(21.0)	70	19.5	54.5					
113.5	(22.5)	68	23.0	57.0	(21.5)	70	22.0	57.0	(20.0)	73	20.5	57.0	
115.0	(23.0)	68	24.0	58.0	(22.0)	70	23.0	58.0	(20.5)	73	21.5	58.0	
116.0	(23.0)	68	25.0	59.0	(22.0)	70	24.0	59.0	(20.5)	73	22.5	59.0	
118.0	(25.0)	68	25.0	59.0	(24.0)	70	24.0	59.0	(22.5)	73	22.5	59.0	
122.5	(26.0)	68	28.5	62.5	(25.0)	70	27.5	62.5	(23.5)	73	26.0	62.5	
127.5	(28.5)	68	31.0	65.0	(27.5)	70	30.0	65.0	(26.0)	73	28.5	65.0	

B940CT

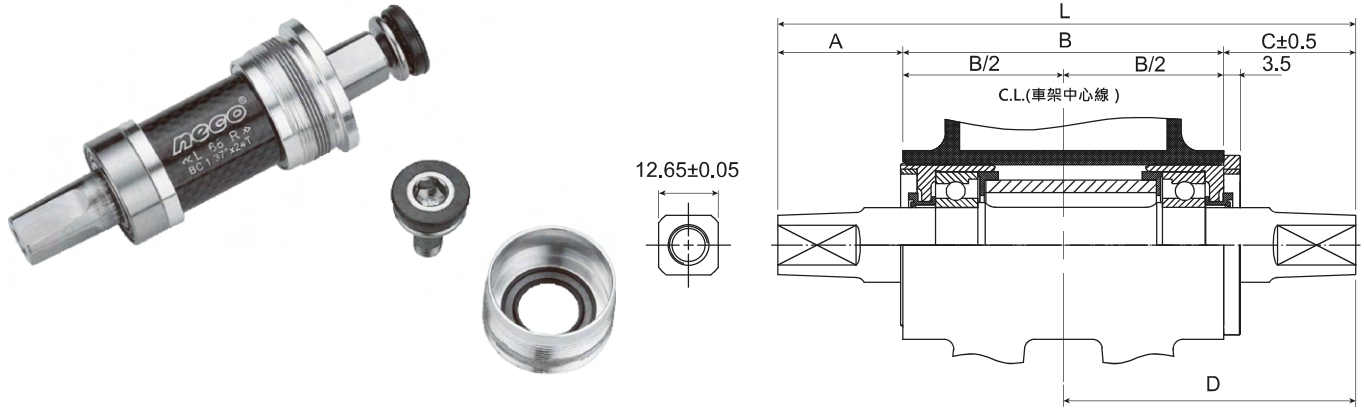

COMPONENTS	內容物	Titanium Hollow Axle, Carbon Body & Alloy cups, Sealed Bearing 2pcs 鈦空心軸心, 碳纖維中管, 鋁碗, 培林x2
APPLICATIONS	適合車種	MTB 登山車, Road 公路車
WEIGHT(LENGTH122.5)	重量(長度122.5)	158g
Threads	牙紋規格	BC 1.37"x24T R/L

LENGTH 中軸長度	B.B. SHELL WIDTH=68mm 五通管寬度 68mm				B.B. SHELL WIDTH=70mm 五通管寬度 70mm				B.B. SHELL WIDTH=73mm 五通管寬度 73mm				
	L	A	B	C	D	A	B	C	D	A	B	C	D
103.0	(16.5)	68	18.5	52.5									
107.5	(19.0)	68	20.5	54.5									
110.5	(22.0)	68	20.5	54.5	(21.0)	70	19.5	54.5					
113.5	(22.5)	68	23.0	57.0	(21.5)	70	22.0	57.0	(20.0)	73	20.5	57.0	
115.0	(23.0)	68	24.0	58.0	(22.0)	70	23.0	58.0	(20.5)	73	21.5	58.0	
116.0	(23.0)	68	25.0	59.0	(22.0)	70	24.0	59.0	(20.5)	73	22.5	59.0	
118.0	(25.0)	68	25.0	59.0	(24.0)	70	24.0	59.0	(22.5)	73	22.5	59.0	
122.5	(26.0)	68	28.5	62.5	(25.0)	70	27.5	62.5	(23.5)	73	26.0	62.5	
127.5	(28.5)	68	31.0	65.0	(27.5)	70	30.0	65.0	(26.0)	73	28.5	65.0	

B952

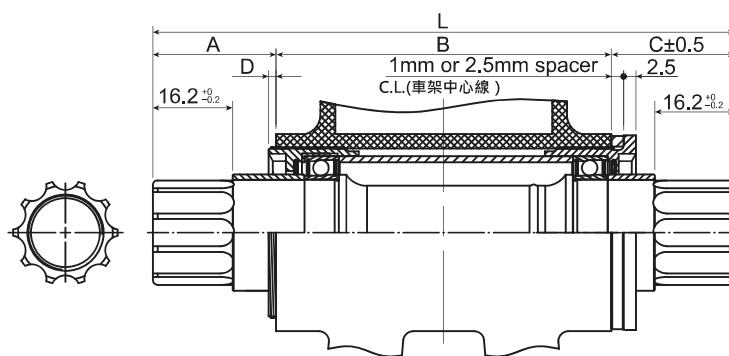

COMPONENTS	內容物	ISIS Spline Hollow Axle(SCM440), Cold Forged & CNC Machined Steel Cups, Steel Body, Sealed Bearing 2pcs 鉻鉬鋼中空軸心, 鐵碗, 鐵中管, 培林x2
WEIGHT(LENGTH118)	重量(長度118)	280g
Threads	牙紋規格	BC 1.37"x24T R/L
B.B Shell Width	五通管寬度	68mm,73mm

LENGTH 中軸長度	B.B. SHELL WIDTH=68mm 五通管寬度 68mm				B.B. SHELL WIDTH=73mm 五通管寬度 73mm			BOLT THREAD 螺絲尺寸
	L	A	B	C	D	A	B	
108.0	20.0	68	20.0 (w/o SPACER)	0	Not Compatible (不相容)			M15xP1
113.0	22.5	68	22.5 (w/2.5mm spacer)	1.5	20.0	73	20.0	M15xP1
118.0	25.0	68	25.0(w/2.5mm spacer)	1.5	22.5	73	22.5	M15xP1
128.0	30.0	68	30.0(w/2.5mm spacer)	1.5	27.5	73	27.5	M12xP1
135.0	33.5	68	33.5(w/2.5mm spacer)	1.5	31.0	73	31.0	M12xP1

B953

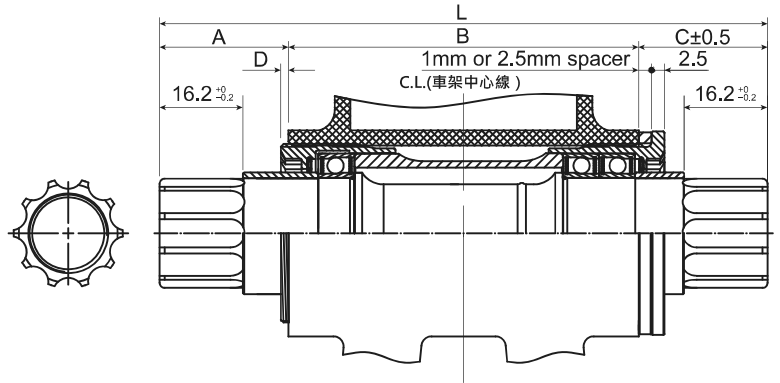

COMPONENTS	內容物	ISIS Spline Hollow Axle(SCM440), Cold Forged & CNC Machined Alloy Cups , w/Dust Seal,Alloy Body , Sealed Bearing 3pcs 鉻鉚鋼中空軸心, 鋁碗防塵套, 鋁中管, 培林x3
WEIGHT(LENGTH118)	重量(長度118)	242g
Threads	牙紋規格	BC 1.37"x24T R/L
B.B Shell Width	五通管寬度	68mm,73mm

LENGTH 中軸長度	B.B. SHELL WIDTH=68mm 五通管寬度 68mm				B.B. SHELL WIDTH=73mm 五通管寬度 73mm			BOLT THREAD 螺絲尺寸
	L	A	B	C	D	A	B	
108.0	20.0	68	20.0 (w/o SPACER)	0	Not Compatible (不相容)			M15xP1
113.0	22.5	68	22.5 (w/2.5mm spacer)	1.5	20.0	73	20.0	M15xP1
118.0	25.0	68	25.0(w/2.5mm spacer)	1.5	22.5	73	22.5	M15xP1
128.0	30.0	68	30.0(w/2.5mm spacer)	1.5	27.5	73	27.5	M12xP1
135.0	33.5	68	33.5(w/2.5mm spacer)	1.5	31.0	73	31.0	M12xP1

B957

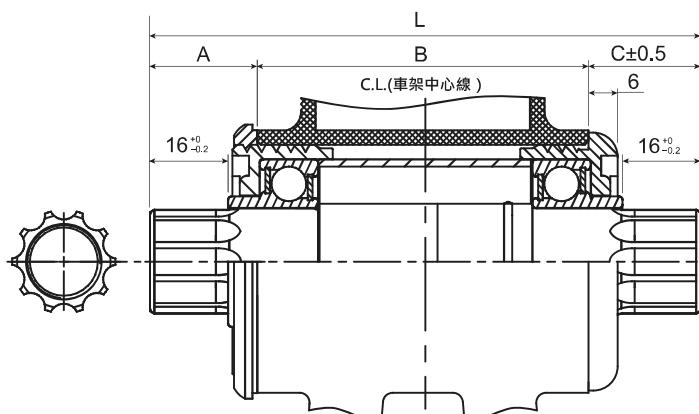

COMPONENTS	內容物	ISIS Spline Hollow Axle(SCM440) Cold Forged& CNC Machined with Alloy Cups w/Dust Seal Steel Body, Sealed Bearing 2pcs 鉻鉬鋼中空軸心, 鋁碗防塵套, 鐵中管, 培林x2
WEIGHT	重量	557g
Threads	牙紋規格	M48xP1.5 R/L
B.B Shell Width	五通管寬度	68mm

LENGTH 中軸長度	B.B. SHELL WIDTH=68mm 五通管寬度 68mm			BOLT THREAD 螺絲尺寸
L	A	B	C	
113.0	22	68	23	M12xP1

BB401

MATERIAL	材質	Forged Alloy & CNC Machined External Cups 鋁碗 Plastic Center Sleeve 塑膠中管
SIZE	尺寸	English Threading 牙紋規格 (BC 1.37"x24T,R/L) for 68mm & 73mm Width 五通管寬度 (68mm&73mm) Oversized Sealed Bearing 密封式軸承 Ø24mm Spindle Ø24mm 軸心
FINISH	表面處理	Anodized Cups 陽極碗
WEIGHT	重量	106g
OPTIONAL	選配	Ceramic Bearing 陶瓷珠軸承
AVAILABLE SYSTEM	適用系統	SHIMANO

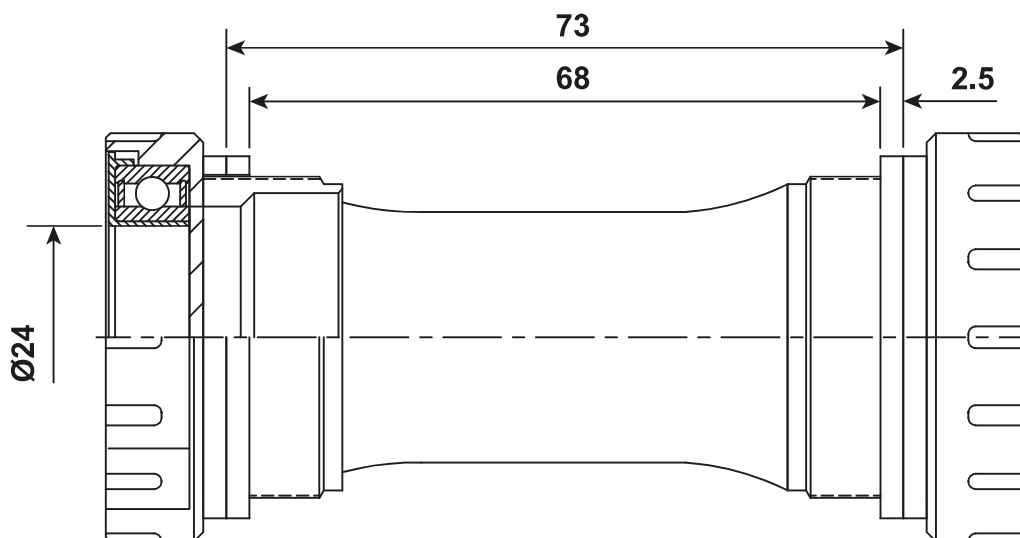

BB501



MATERIAL	材質	Forged Alloy & CNC Machined External Cups 鋁碗 Plastic Center Sleeve 塑膠中管
SIZE	尺寸	English Threading 牙紋規格(BC 1.37"x24T, R/L) for 68mm & 73mm Width 五通管寬度(68mm&73mm) Oversized Sealed Bearing 密封式軸承 Spindle OD Left 軸心左端外徑(Crank-Side曲柄側): $\varnothing 22$ mm Spindle OD Right 軸心右端外徑(Crainwheel-Side曲柄側): $\varnothing 24$ mm
FINISH	表面處理	Anodized Cups 陽極碗
WEIGHT	重量	116g
OPTIONAL	選配	Ceramic Bearing 陶瓷珠軸承
AVAILABLE SYSTEM	適用系統	SRAM

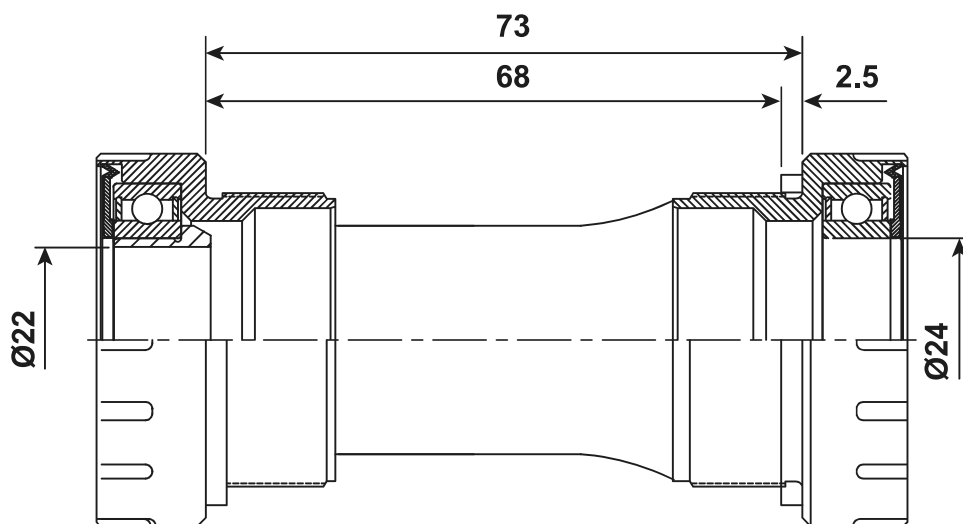

BB86 / BB90 / BB92**PRESS FIT TYPE 壓入式五通碗組**

MATERIAL	材質	Forged Alloy & CNC Machined External Cups 鋁碗 Plastic Center Sleeve 塑膠中管
SIZE	尺寸	Ø24mm Spindle OD Ø24mm 軸心外徑
Available For	可適用於	86.5mm Frame B.B Shell Width 86.5mm寬之車架五通管 90mm Frame B.B Shell Width 90mm寬之車架五通管 92mm Frame B.B Shell Width 92mm寬之車架五通管 Press Fit Cups (壓入式碗 Ø41mm)
FINISH	表面處理	Anodized Cups 陽極碗
WEIGHT	重量	95g
BB SHELL ID	五通管內徑	Ø41mm

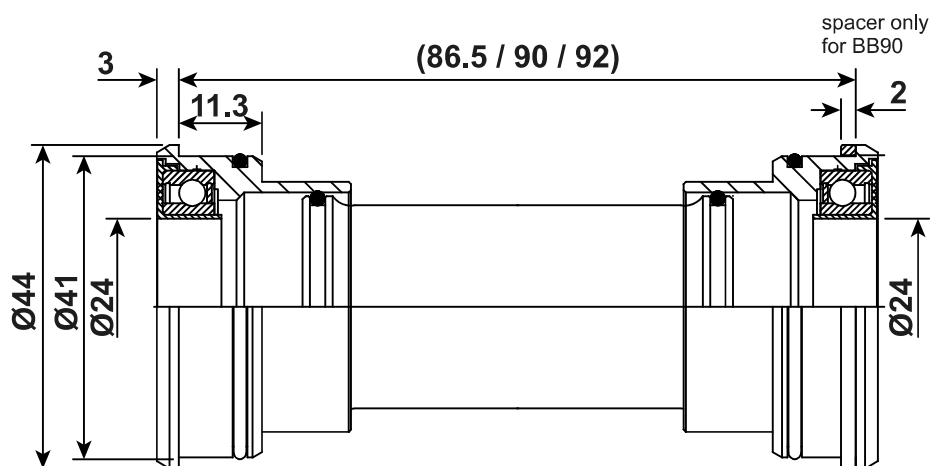

BT4724 - 86 - 0S

MATERIAL	材質	Alloy Cups And Body
Threads	牙紋規格	M47xP1.0
B.B Shell	五通	w86/92mm
Crank Spec	牙盤規格	For SHIMANO Ø24mm Crankset
Bearing	培林	Sealed Bearing 密封式培林
OPTIONAL	選配	Ceramic Bearing 陶瓷珠軸承
Available For Tool Notch	可用工具	Notch 16T O.D. 44mm

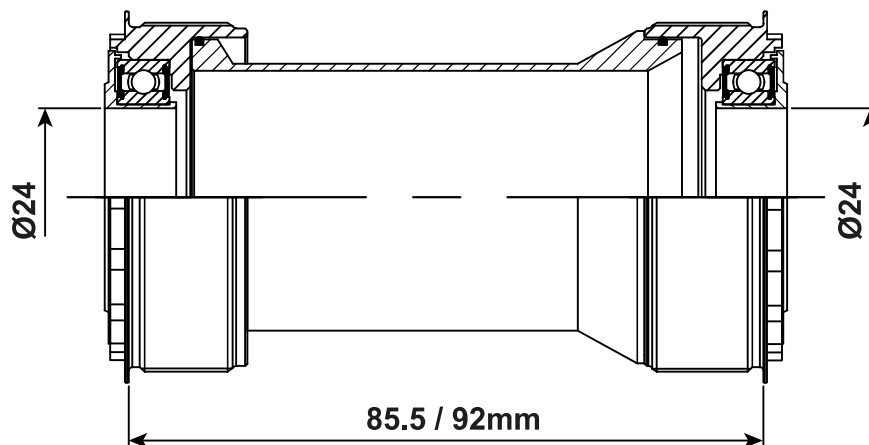

BT4729 - 86 - 0S

MATERIAL	材質	Alloy Cups And Body
Threads	牙紋規格	M47xP1.0
B.B Shell	五通	w86/92mm
Crank Spec	牙盤規格	For SRAM DUB Ø28.99mm Crankset
Bearing	培林	Sealed Bearing 密封式培林
OPTIONAL	選配	Ceramic Bearing 陶瓷珠軸承
Available For Tool Notch	可用工具	Notch 16T O.D. 48.5mm

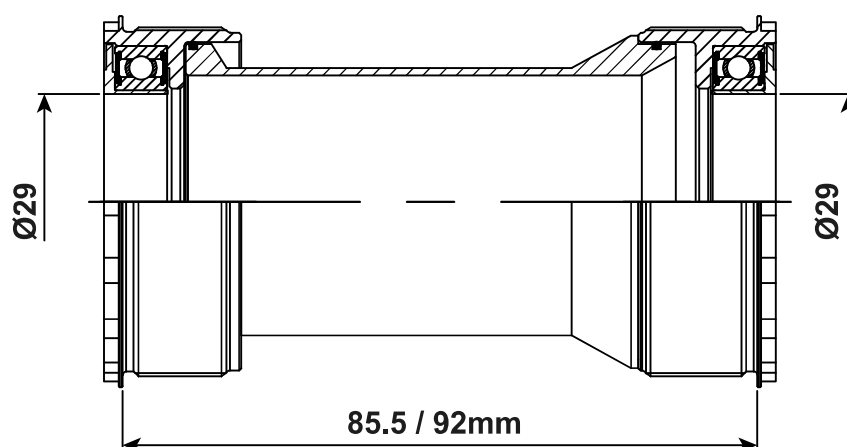

BT4730 - 86 - 0S

MATERIAL	材質	Alloy Cups And Body
Threads	牙紋規格	M47xP1.0
B.B Shell	五通	w86/92mm
Crank Spec	牙盤規格	For Ø30mm Crankset
Bearing	培林	Sealed Bearing 密封式培林
OPTIONAL	選配	Ceramic Bearing 陶瓷珠軸承
Available For Tool Notch	可用工具	Notch 16T O.D. 48.5mm

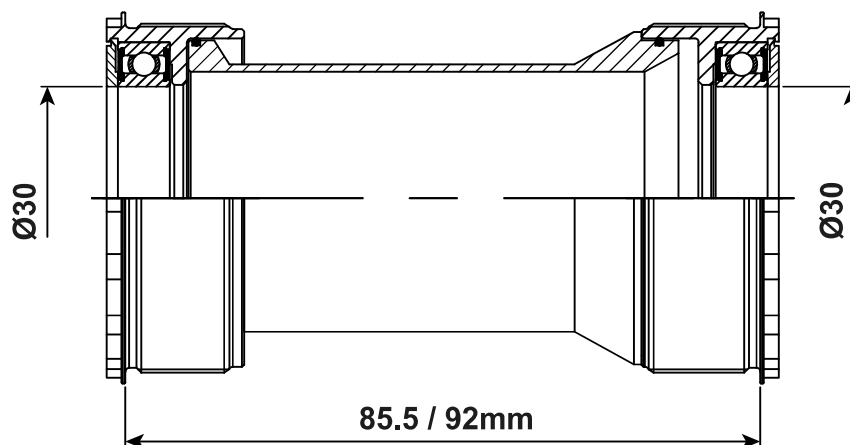

BPF3024 - 68 - 0S



MATERIAL	材質	Alloy Cups And Body
Structure	結構	Center threaded locking on design 中心螺紋鎖固設計
B.B Shell	五通	w68/73mm x dia.46mm
Crank Spec	牙盤規格	For SHIMANO Ø24mm Crankset
Bearing	培林	Sealed Bearing 密封式培林
OPTIONAL	選配	Ceramic Bearing 陶瓷珠軸承
Available For Tool Notch	可用工具	Notch 16T O.D. 44mm

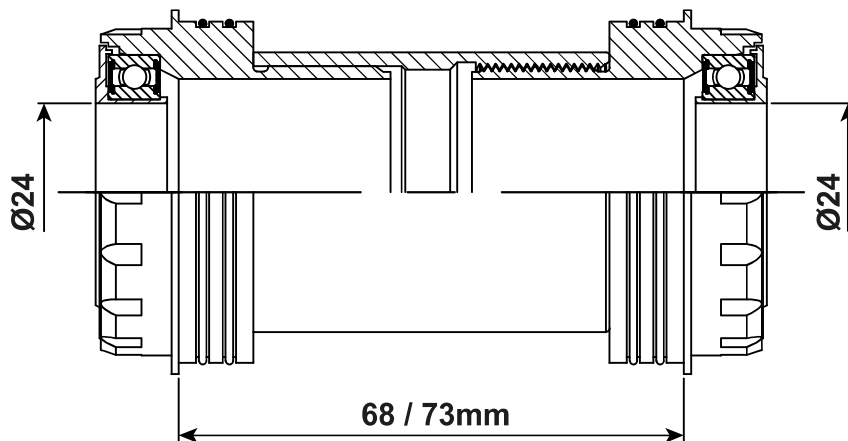

B38624 - 86 - 0S

MATERIAL	材質	Alloy Cups And Body
Structure	結構	Center threaded locking on design 中心螺紋鎖固設計
B.B Shell	五通	w86/92mm x dia.46mm
Crank Spec	牙盤規格	For SHIMANO Ø24mm Crankset
Bearing	培林	Sealed Bearing 密封式培林
OPTIONAL	選配	Ceramic Bearing 陶瓷珠軸承
Available For Tool Notch	可用工具	Notch 16T O.D. 48.5mm

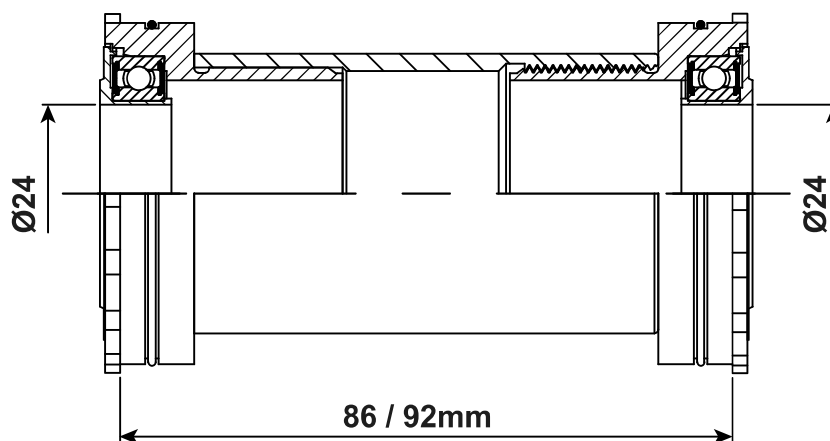

B881



BSA 1.37"x 24T R/L

MATERIAL	材料	Steel, Set of 5pcs 鐵 x 5pcs
ROTATOR	轉動機構	Ball Retainers 珠巢 1/4"x9x2pcs
FINISH	表面處理	CP, UCP, ED, BK
APPLICATIONS	通用車種	Light Weight 輕便車, Mini Cycle 小車

B882



BSA 1.37"x 24T R/L

MATERIAL	材料	Steel, Set of 5pcs 鐵 x 5pcs
ROTATOR	轉動機構	Ball Retainers 珠巢 1/4"x9x2pcs
FINISH	表面處理	CP, UCP, ED, BK
APPLICATIONS	通用車種	Light Weight 輕便車, Mini Cycle 小車

B886



BSA 1.37"x 24T R/L

MATERIAL	材料	Steel, Set of 6pcs 鐵 x 6pcs
ROTATOR	轉動機構	Ball Retainers 珠巢 1/4"x9x2pcs
FINISH	表面處理	CP, UCP, ED, BK
		Comfort(w/Chain Guard)
APPLICATIONS	通用車種	城市車 (加鏈條保護蓋)

B887(B887B)



B887: BSA 1.37"x24T, R/L
B887B: Italian 36mmx24T, R/R

MATERIAL	材料	Steel, Set of 5pcs 鐵 x 5pcs
ROTATOR	轉動機構	Ball Retainers 珠巢 1/4"x9x2pcs
FINISH	表面處理	CP, UCP, ED, BK
APPLICATIONS	通用車種	Light Weight 輕便車, Mini Cycle 小車

B888

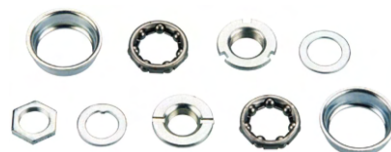

CUP SIZE	碗尺寸	Ø43mm
		Left Cone: 3/4"un24T-LH
		Right Cone: 13/16"un24T
THREAD TYPE	牙紋	
MATERIAL	材料	Steel, Set of 9pcs 鐵 x 9pcs
ROTATOR	轉動機構	Ball Retainers 珠巢 5/16"x7x2pcs
FINISH	表面處理	UCP, BK
APPLICATIONS	通用車種	Children Bike 童車

B889



CUP SIZE	碗尺寸	Ø51.5mm
THREAD TYPE	牙紋	Left Cone: 7/8"un24T-LH
		Right Cone: 15/16"un24T
MATERIAL	材料	Steel, Set of 9pcs 鐵 x 9pcs
ROTATOR	轉動機構	Ball Retainers 珠巢 5/16"x9x2pcs
FINISH	表面處理	UCP, BK
APPLICATIONS	通用車種	BMX & Freestyle 表演車

B890



CUP SIZE	碗尺寸	Ø45mm
		Left Cone: 22un 24T-LH
		Right Cone: 23.2un 32T
THREAD TYPE	牙紋	
MATERIAL	材料	Steel, Set of 10pcs 鐵 x 10pcs
ROTATOR	轉動機構	Ball Retainers 珠巢 1/4" x 11C x 2pcs
FINISH	表面處理	UCP, BK

B890B



CUP SIZE	碗尺寸	Ø45mm
		Left Cone: 22un 24T-LH
		Right Cone: 23.2un 32T
THREAD TYPE	牙紋	
MATERIAL	材料	Steel, Set of 6pcs 鐵 x 6pcs
ROTATOR	轉動機構	Sealed Bearing 培林
FINISH	表面處理	UCP

PEDALS

腳踏



NECO

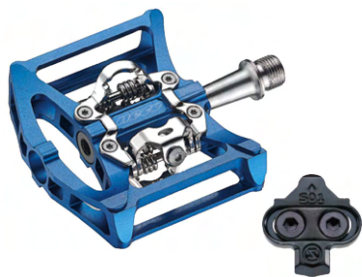

WP-MC118

BODY	本體材質	Aluminum, CNC-machined body CNC精密加工鋁合金本體
AXLE	軸心材質	CNC-machined Cr-Mo CNC 精密加工鉻鉬鋼軸心
BEARING	轉動結構	LSL bushing & sealed 自潤軸承, 密封式培林
BINDING	後蓋	Dual-sided Cr-Mo, tension adjustable 雙面鉻鉬鋼, 可依騎乘者喜好及使用習慣調整
CLEAT	扣片	WP-S01
SIZE	本體尺寸	103x96mm
WEIGHT	重量	204g/pair



WP-MC120

BODY	本體材質	Aluminum, CNC-machined body CNC精密加工鋁合金本體
AXLE	軸心材質	CNC-machined Cr-Mo CNC 精密加工鉻鉬鋼軸心
BEARING	轉動結構	LSL bushing & sealed 自潤軸承, 密封式培林
BINDING	後蓋	Dual-sided Cr-Mo, tension adjustable 雙面鉻鉬鋼, 可依騎乘者喜好及使用習慣調整
CLEAT	扣片	WP-S01
SIZE	本體尺寸	82x55mm
WEIGHT	重量	142g/pair



WP321-N

BODY	本體材質	Aluminum 鋁
AXLE	軸心材質	Cr-Mo 鉻鉬鋼
BEARING	轉動結構	Sealed Bearing & Sleeve Bearing 密封式培林, 自潤軸承
SIZE	本體尺寸	87x53mm
WEIGHT	重量	184g/pair



WP608S

BODY	本體材質	Aluminum 鋁
AXLE	軸心材質	Cr-Mo 鉻鉬鋼
BEARING	轉動結構	Sealed Bearing & Sleeve Bearing 密封式培林, 自潤軸承
SIZE	本體尺寸	82x105mm
WEIGHT	重量	271g/pair



WP701D

BODY	本體材質	Aluminum 鋁
AXLE	軸心材質	Cr-Mo 鉻鉬鋼
BEARING	轉動結構	Sealed Bearing & Sleeve Bearing 密封式培林, 自潤軸承
SIZE	本體尺寸	93x98mm
WEIGHT	重量	340g/pair



WP702D

BODY	本體材質	Aluminum 鋁
AXLE	軸心材質	Cr-Mo 鉻鉬鋼
BEARING	轉動結構	Sealed Bearing & Sleeve Bearing 密封式培林, 自潤軸承
SIZE	本體尺寸	109x121mm
WEIGHT	重量	349g/pair



WP703S

BODY	本體材質	Aluminum 鋁
AXLE	軸心材質	Cr-Mo 塔鉬鋼
BEARING	轉動結構	Sealed Bearing 密封式培林
SIZE	本體尺寸	110x105mm
WEIGHT	重量	327g/pair



WP704D

BODY	本體材質	Aluminum 鋁
AXLE	軸心材質	Cr-Mo 鉻鉬鋼
BEARING	轉動結構	Sealed Bearing & Sleeve Bearing 密封式培林, 自潤軸承
SIZE	本體尺寸	88x99mm
WEIGHT	重量	219g/pair

NECO PEDALS

腳踏 PEDALS



WP706D

BODY	本體材質	Aluminum 鋁
AXLE	軸心材質	Cr-Mo 鎢鉻鋼
BEARING	轉動結構	Sealed Bearing & Sleeve Bearing 密封式培林, 自潤軸承
SIZE	本體尺寸	101x119mm
WEIGHT	重量	342g/pair



WP720D

BODY	本體材質	Aluminum 鋁
AXLE	軸心材質	Cr-Mo 鎢鉻鋼
BEARING	轉動結構	Sealed Bearing & Sleeve Bearing 密封式培林, 自潤軸承
SIZE	本體尺寸	100x105mm
WEIGHT	重量	303g/pair



WP721S

BODY	本體材質	Aluminum 鋁
AXLE	軸心材質	Cr-Mo 鎢鉻鋼
BEARING	轉動結構	Sealed Bearing & Sleeve Bearing 密封式培林, 自潤軸承
SIZE	本體尺寸	100x116mm
WEIGHT	重量	298g/pair



WP722

BODY	本體材質	Aluminum 鋁
AXLE	軸心材質	Cr-Mo 鎢鉻鋼
BEARING	轉動結構	Sealed Bearing*3 密封式培林3PCS
SIZE	本體尺寸	99x118mm
WEIGHT	重量	360g/pair



WP725D

BODY	本體材質	Aluminum 鋁
AXLE	軸心材質	Cr-Mo 鎢鉻鋼
BEARING	轉動結構	Sealed Bearing & Sleeve Bearing 密封式培林, 自潤軸承
SIZE	本體尺寸	90x102mm
WEIGHT	重量	213g/pair



WP728D

BODY	本體材質	Aluminum 鋁
AXLE	軸心材質	Cr-Mo 鎢鉻鋼
BEARING	轉動結構	Sealed Bearing & Sleeve Bearing 密封式培林, 自潤軸承
SIZE	本體尺寸	90x106mm
WEIGHT	重量	209g/pair



WP729D

BODY	本體材質	Aluminum 鋁
AXLE	軸心材質	Cr-Mo 鎢鉻鋼
BEARING	轉動結構	Sealed Bearing & Sleeve Bearing 密封式培林, 自潤軸承
SIZE	本體尺寸	85x100mm
WEIGHT	重量	255g/pair



WP769S

BODY	本體材質	Aluminum 鋁
AXLE	軸心材質	Cr-Mo 鎢鉻鋼
BEARING	轉動結構	Sealed Bearing & Sleeve Bearing 密封式培林, 自潤軸承
SIZE	本體尺寸	97x118mm
WEIGHT	重量	343g/pair



WP902

BODY	本體材質	Aluminum 鋁
AXLE	軸心材質	Cr-Mo 鎢鉻鋼
BEARING	轉動結構	Sealed Bearing & Sleeve Bearing 密封式培林, 自潤軸承
SIZE	本體尺寸	108x105mm
WEIGHT	重量	384g/pair



WP903

BODY 本體材質	Aluminum 鋁
AXLE 軸心材質	Cr-Mo 鉻鉬鋼
BEARING 轉動結構	Sealed Bearing & Sleeve Bearing 密封式培林, 自潤軸承
SIZE 本體尺寸	108x100mm
WEIGHT 重量	372g/pair



WP904

BODY 本體材質	Aluminum 鋁
AXLE 軸心材質	Cr-Mo 鉻鉬鋼
BEARING 轉動結構	Sealed Bearing & Sleeve Bearing 密封式培林, 自潤軸承
SIZE 本體尺寸	108x105mm
WEIGHT 重量	382g/pair



WP580

BODY 本體材質	Aluminum+PP Body With Inlaid Anti-Slip Rubber 鋁+防滑橡膠
AXLE 軸心材質	Cr-Mo 鉻鉬鋼
BEARING 轉動結構	Sleeve Bearing 自潤軸承
SIZE 本體尺寸	98x79mm
WEIGHT 重量	365/pair



WP908A

BODY 本體材質	Aluminum 鋁
AXLE 軸心材質	Cr-Mo 鉻鉬鋼
BEARING 轉動結構	Sealed Bearing & Sleeve Bearing 密封式培林, 自潤軸承
SIZE 本體尺寸	108x108mm
WEIGHT 重量	522g/pair



WP101

BODY 本體材質	Aluminum 鋁
AXLE 軸心材質	Cr-Mo 鉻鉬鋼
BEARING 轉動結構	Sealed Bearing & Sleeve Bearing 密封式培林, 自潤軸承
SIZE 本體尺寸	103x63mm
WEIGHT 重量	273g/pair



WP97D

BODY 本體材質	Aluminum 鋁
AXLE 軸心材質	Steel 鐵
BEARING 轉動結構	Ball Bearing 珠巢
SIZE 本體尺寸	103x63mm
WEIGHT 重量	397g/pair



WP625

BODY 本體材質	Aluminum 鋁
AXLE 軸心材質	Steel 鐵
BEARING 轉動結構	Ball Bearing 珠巢
SIZE 本體尺寸	109x96mm
WEIGHT 重量	435g/pair



WP97

BODY 本體材質	Aluminum 鋁
AXLE 軸心材質	Steel 鐵
BEARING 轉動結構	Ball Bearing 珠巢
SIZE 本體尺寸	120x85mm
WEIGHT 重量	390g/pair



WP908-2

BODY 本體材質	Aluminum 鋁
AXLE 軸心材質	Steel 鐵
BEARING 轉動結構	Ball Bearing 珠巢
SIZE 本體尺寸	109x105mm
WEIGHT 重量	460g/pair

NECO PEDALS

腳踏 PEDALS



WP303

BODY	本體材質	Aluminum 鋁
AXLE	軸心材質	Steel 鐵
BEARING	轉動結構	Ball Bearing 珠巢
SIZE	本體尺寸	110x104mm
WEIGHT	重量	440g/pair



WP313

BODY	本體材質	Aluminum 鋁
AXLE	軸心材質	Steel 鐵
BEARING	轉動結構	Ball Bearing 珠巢
SIZE	本體尺寸	109x100mm
WEIGHT	重量	449g/pair



WP893

BODY	本體材質	Aluminum 鋁
AXLE	軸心材質	Steel 鐵
BEARING	轉動結構	Ball Bearing 珠巢
SIZE	本體尺寸	103x62mm
WEIGHT	重量	402g/pair



WP895

BODY	本體材質	Aluminum 鋁
AXLE	軸心材質	Steel 鐵
BEARING	轉動結構	Ball Bearing 珠巢
SIZE	本體尺寸	104x77mm
WEIGHT	重量	459g/pair



WP897

BODY	本體材質	Aluminum 鋁
AXLE	軸心材質	Steel 鐵
BEARING	轉動結構	Ball Bearing 珠巢
SIZE	本體尺寸	105x76mm
WEIGHT	重量	399g/pair



WP916

BODY	本體材質	Aluminum 鋁
AXLE	軸心材質	Steel 鐵
BEARING	轉動結構	Ball Bearing 珠巢
SIZE	本體尺寸	113x108mm
WEIGHT	重量	510g/pair



WP931A/S

BODY	本體材質	PP 塑料聚丙稀
CAGE	外框	WP931A:Aluminum鋁 WP931S:Steel鐵
AXLE	軸心材質	Steel 鐵
BEARING	轉動結構	Ball Bearing 珠巢
SIZE	本體尺寸	103x79mm
WEIGHT	重量	Aluminum鋁:342.5g/pair Steel鐵:405.5g/pair

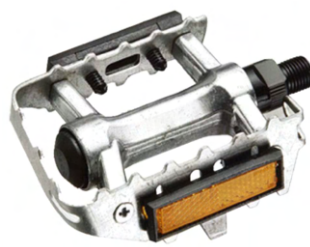

WP932

BODY	本體材質	Aluminum 鋁
CAGE	外框	Aluminum 鋁
AXLE	軸心材質	Steel 鐵
BEARING	轉動結構	Ball Bearing 珠巢
SIZE	本體尺寸	102x81mm
WEIGHT	重量	336g/pair



WP940

BODY	本體材質	PP+Aluminum 塑料聚丙稀+鋁
AXLE	軸心材質	Steel 鐵
BEARING	轉動結構	Ball Bearing 珠巢
SIZE	本體尺寸	109x68mm
WEIGHT	重量	425g/pair



WP940-1

BODY 本體材質	PP 塑料聚丙烯+Aluminum 鋁
AXLE 軸心材質	Steel 鐵
BEARING 轉動結構	Ball Bearing 珠巢
SIZE 本體尺寸	101x76mm
WEIGHT 重量	401.5g/pair



WP201A/S

BODY 本體材質	Plastic 塑膠
CAGE 外框	WP201A:Aluminum鋁 WP201S:Steel鐵
AXLE 軸心材質	Steel 鐵
BEARING 轉動結構	Ball Bearing 珠巢
SIZE 本體尺寸	102x63mm
WEIGHT 重量	Aluminum鋁:332g/pair Steel鐵:425g/pair



WP502

BODY 本體材質	PP 塑料聚丙烯
AXLE 軸心材質	Steel 鐵
BEARING 轉動結構	Sleeve Bearing 自潤軸承
SIZE 本體尺寸	105x97mm
WEIGHT 重量	273g/pair
OPTIONAL 備註	WP520-1 Ball Bearing 珠巢:320g/pair



WP601

BODY 本體材質	PC Body 聚碳酸酯
AXLE 軸心材質	Steel 鐵
BEARING 轉動結構	Ball Bearing 珠巢
SIZE 本體尺寸	110x100mm
WEIGHT 重量	415g/pair
可選顏色 AVAILABLE FINISH	Transparent Clear透明 / Red紅 / Blue藍 / Purple紫 / Green綠 / Yellow黃



WP208

BODY 本體材質	One-Piece Black PP+ Grey Rubber 一體成型塑膠+灰橡膠
AXLE 軸心材質	Steel 鐵
BEARING 轉動結構	Ball Bearing 珠巢
SIZE 本體尺寸	114x85mm
WEIGHT 重量	404.5g/pair



WP108

BODY 本體材質	One-Piece Black PP+ Grey Rubber 一體成型塑膠+灰橡膠
AXLE 軸心材質	Steel 鐵
BEARING 轉動結構	Ball Bearing 珠巢
SIZE 本體尺寸	111x85mm
WEIGHT 重量	380g/pair



WP940-2

BODY 本體材質	PP 塑料聚丙烯
AXLE 軸心材質	Steel 鐵
BEARING 轉動結構	Ball Bearing 珠巢
SIZE 本體尺寸	100x86mm
WEIGHT 重量	326g/pair



WP302

BODY 本體材質	One-Piece Black PP+ Grey Rubber 一體成型塑膠+灰橡膠
AXLE 軸心材質	Steel 鐵
BEARING 轉動結構	Ball Bearing 珠巢
SIZE 本體尺寸	109x73mm
WEIGHT 重量	375.5g/pair



WP301

BODY 本體材質	PP 塑料聚丙烯
AXLE 軸心材質	Steel 鐵
BEARING 轉動結構	Ball Bearing 珠巢
SIZE 本體尺寸	108x74mm
WEIGHT 重量	336.5g/pair

NECO PEDALS

腳踏 PEDALS



WP402

BODY 本體材質	PP 塑料聚丙烯
AXLE 軸心材質	Steel 鐵
BEARING 轉動結構	Ball Bearing 珠巢
SIZE 本體尺寸	62x87mm
WEIGHT 重量	245g/pair



WP195

BODY 本體材質	PP 塑料聚丙烯
AXLE 軸心材質	Steel 鐵
BEARING 轉動結構	Ball Bearing 珠巢
SIZE 本體尺寸	109x87mm
WEIGHT 重量	314g/pair



WP188

BODY 本體材質	PP 塑料聚丙烯
AXLE 軸心材質	Steel 鐵
BEARING 轉動結構	Ball Bearing 珠巢
SIZE 本體尺寸	110x73mm
WEIGHT 重量	320g/pair



WP178

BODY 本體材質	PP 塑料聚丙烯
AXLE 軸心材質	Steel 鐵
BEARING 轉動結構	Ball Bearing 珠巢
SIZE 本體尺寸	109x78mm
WEIGHT 重量	333.5g/pair



WP403

BODY 本體材質	PP 塑料聚丙烯
AXLE 軸心材質	Steel 鐵
BEARING 轉動結構	Ball Bearing 珠巢
SIZE 本體尺寸	108x95mm
WEIGHT 重量	345g/pair



WP128

BODY 本體材質	PP 塑料聚丙烯
AXLE 軸心材質	Steel 鐵
BEARING 轉動結構	Ball-less 無珠
SIZE 本體尺寸	96x59mm
WEIGHT 重量	222g/pair



WP941-1

BODY 本體材質	PP 塑料聚丙烯
AXLE 軸心材質	Steel 鐵
BEARING 轉動結構	Ball Bearing 珠巢
SIZE 本體尺寸	114x70mm
WEIGHT 重量	400g/pair



WP303-1

BODY 本體材質	PP 塑料聚丙烯
AXLE 軸心材質	Steel 鐵
BEARING 轉動結構	Ball Bearing 珠巢
SIZE 本體尺寸	109x69mm
WEIGHT 重量	323g/pair



WP501

BODY 本體材質	PP 塑料聚丙烯
AXLE 軸心材質	Steel 鐵
BEARING 轉動結構	Self Moistening 自潤軸套
SIZE 本體尺寸	102x90mm
WEIGHT 重量	253g/pair



WP138

BODY 本體材質	PP 塑料聚丙烯
AXLE 軸心材質	Steel 鐵
BEARING 轉動結構	Ball Bearing 珠巢
SIZE 本體尺寸	91x63mm
WEIGHT 重量	295g/pair

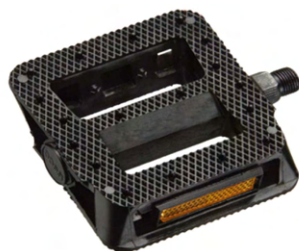

WP406

BODY 本體材質	PP 塑料聚丙烯
AXLE 軸心材質	Steel 鐵
BEARING 轉動結構	Ball Bearing 珠巢
SIZE 本體尺寸	109x115mm
WEIGHT 重量	411g/pair



WP408

BODY 本體材質	PP 塑料聚丙烯
AXLE 軸心材質	Steel 鐵
BEARING 轉動結構	Ball Bearing 珠巢
SIZE 本體尺寸	110x96mm
WEIGHT 重量	360g/pair



WP401

BODY 本體材質	PP 塑料聚丙烯
AXLE 軸心材質	Steel 鐵
BEARING 轉動結構	Ball Bearing 珠巢
SIZE 本體尺寸	111x100mm
WEIGHT 重量	343.5g/pair



WP168

BODY 本體材質	PP 塑料聚丙烯
AXLE 軸心材質	Steel 鐵
BEARING 轉動結構	Ball Bearing 珠巢
SIZE 本體尺寸	110x84mm
WEIGHT 重量	296.5g/pair
OPTIONAL 備註	WP168B(Ball-less無珠) Steel Axle 鐵軸心 272g/pair



WP163

BODY 本體材質	PP 塑料聚丙烯
AXLE 軸心材質	Steel 鐵
BEARING 轉動結構	Ball Bearing 珠巢
SIZE 本體尺寸	114x85mm
WEIGHT 重量	310g/pair



WP251

BODY 本體材質	PP 塑料聚丙烯
AXLE 軸心材質	Steel 鐵
BEARING 轉動結構	Ball Bearing 珠巢
SIZE 本體尺寸	99x76mm
WEIGHT 重量	287g/pair



WP190

BODY 本體材質	PP 塑料聚丙烯
AXLE 軸心材質	Steel 鐵
BEARING 轉動結構	Ball Bearing 珠巢
SIZE 本體尺寸	109x72mm
WEIGHT 重量	337.5g/pair



WP148

BODY 本體材質	PP 塑料聚丙烯
AXLE 軸心材質	Steel 鐵
BEARING 轉動結構	Ball Bearing 珠巢
SIZE 本體尺寸	92x62mm
WEIGHT 重量	281g/pair
OPTIONAL 備註	WP148B(Ball-less無珠) Steel Axle 鐵軸心 248g/pair



WP206

BODY	本體材質	Nylon 尼龍
AXLE	軸心材質	Steel 鐵
BEARING	轉動結構	Ball Bearing 珠巢
SIZE	本體尺寸	68x105mm
WEIGHT	重量	372g/pair



WP209A

BODY	本體材質	Aluminum+PP 鋁+塑料聚丙稀
AXLE	軸心材質	Steel 鐵
BEARING	轉動結構	Ball Bearing 珠巢
SIZE	本體尺寸	68x110mm
WEIGHT	重量	376g/pair

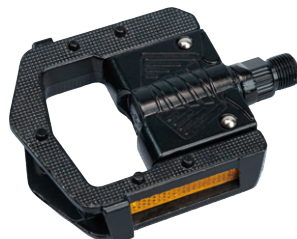

WP210

BODY	本體材質	Aluminum 鋁
AXLE	軸心材質	Steel 鐵
BEARING	轉動結構	Sleeve Bearing 自潤軸承
SIZE	本體尺寸	80x105mm
WEIGHT	重量	466g/pair



WP239

BODY	本體材質	PP 塑料聚丙稀
AXLE	軸心材質	Steel 鐵
BEARING	轉動結構	Ball Bearing 珠巢
SIZE	本體尺寸	101x112mm
WEIGHT	重量	312g/pair



WP308

BODY	本體材質	Aluminum Die Cast Body 鋁壓鑄
AXLE	軸心材質	Steel 鐵
BEARING	轉動結構	Sealed Bearing & Sleeve Bearing 密封式培林, 自潤軸承
SIZE	本體尺寸	91x105mm
WEIGHT	重量	386g/pair



WP309

BODY	本體材質	Aluminum Die Cast Body 鋁壓鑄
AXLE	軸心材質	Steel 鐵
BEARING	轉動結構	Sealed Bearing & Sleeve Bearing 密封式培林, 自潤軸承
SIZE	本體尺寸	98x106mm
WEIGHT	重量	352g/pair



WP337B

BODY	本體材質	Aluminum 鋁
AXLE	軸心材質	Steel 鐵
BEARING	轉動結構	Sealed Bearing*3 密封式培林3PCS
SIZE	本體尺寸	99x108mm
WEIGHT	重量	420g/pair

NECO PEDALS

腳踏 PEDALS



WP405

BODY	本體材質	PP 塑料聚丙烯
AXLE	軸心材質	Steel 鐵
BEARING	轉動結構	Ball Bearing 珠巢
SIZE	本體尺寸	83x98 mm
WEIGHT	重量	268g/pair



WP405D

BODY	本體材質	PP 塑料聚丙烯
AXLE	軸心材質	Steel 鐵
BEARING	轉動結構	Ball Bearing 珠巢
SIZE	本體尺寸	92x107mm
WEIGHT	重量	284g/pair



WP407

BODY	本體材質	PP 塑料聚丙烯
AXLE	軸心材質	Steel 鐵
BEARING	轉動結構	Sleeve Bearing 自潤軸承
SIZE	本體尺寸	98x105mm
WEIGHT	重量	268.8g/pair



WP409

BODY	本體材質	PP 塑料聚丙烯
AXLE	軸心材質	Steel 鐵
BEARING	轉動結構	Sleeve Bearing 自潤軸承
SIZE	本體尺寸	106x111mm
WEIGHT	重量	276g/pair



WP606

BODY	本體材質	Aluminum 鋁
AXLE	軸心材質	Steel 鐵
BEARING	轉動結構	Sleeve Bearing 自潤軸承
SIZE	本體尺寸	99x105mm
WEIGHT	重量	316g/pair

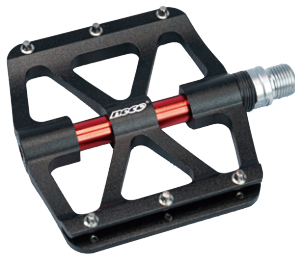

WP705D

BODY	本體材質	Aluminum 鋁
AXLE	軸心材質	Steel 鐵
BEARING	轉動結構	Sealed Bearing & Sleeve Bearing 密封式培林, 自潤軸承
SIZE	本體尺寸	105x110mm
WEIGHT	重量	390g/pair
OPTIONAL	備註	WP705:3Sealed Bearing3培林



WP711D

BODY	本體材質	Aluminum 鋁
AXLE	軸心材質	Steel 鐵
BEARING	轉動結構	Sealed Bearing & Sleeve Bearing 密封式培林, 自潤軸承
SIZE	本體尺寸	98x115mm
WEIGHT	重量	340g/pair
OPTIONAL	備註	WP711:3Sealed Bearing3培林



WP713

BODY	本體材質	Aluminum 鋁
AXLE	軸心材質	Steel 鐵
BEARING	轉動結構	Sleeve Bearing 自潤軸承
SIZE	本體尺寸	84x99 mm
WEIGHT	重量	228g/pair



WP719D

BODY	本體材質	Aluminum 鋁
AXLE	軸心材質	Steel 鐵
BEARING	轉動結構	Sealed Bearing & Sleeve Bearing 密封式培林,自潤軸承
SIZE	本體尺寸	102x110mm
WEIGHT	重量	321g/pair
OPTIONAL	備註	WP719:3Sealed Bearing3培林



WP727D

BODY	本體材質	Aluminum 鋁
AXLE	軸心材質	Steel 鐵
BEARING	轉動結構	Sealed Bearing & Sleeve Bearing 密封式培林,自潤軸承
SIZE	本體尺寸	85x95mm
WEIGHT	重量	240g/pair
OPTIONAL	備註	WP727:3Sealed Bearing3培林



WP733D

BODY	本體材質	Aluminum 鋁
AXLE	軸心材質	Steel 鐵
BEARING	轉動結構	Sealed Bearing & Sleeve Bearing 密封式培林,自潤軸承
SIZE	本體尺寸	110x110mm
WEIGHT	重量	348g/pair
OPTIONAL	備註	WP733:3Sealed Bearing3培林



WP735D

BODY	本體材質	Aluminum 鋁
AXLE	軸心材質	Steel 鐵
BEARING	轉動結構	Sealed Bearing & Sleeve Bearing 密封式培林,自潤軸承
SIZE	本體尺寸	98x115mm
WEIGHT	重量	330g/pair
OPTIONAL	備註	WP735:3Sealed Bearing3培林



WP736D

BODY	本體材質	Aluminum 鋁
AXLE	軸心材質	Steel 鐵
BEARING	轉動結構	Sealed Bearing & Sleeve Bearing 密封式培林,自潤軸承
SIZE	本體尺寸	99x106mm
WEIGHT	重量	366g/pair
OPTIONAL	備註	WP736:3Sealed Bearing3培林



WP761D

BODY	本體材質	Aluminum 鋁
AXLE	軸心材質	Steel 鐵
BEARING	轉動結構	Sealed Bearing & Sleeve Bearing 密封式培林,自潤軸承
SIZE	本體尺寸	98x114mm
WEIGHT	重量	366g/pair
OPTIONAL	備註	WP761:3Sealed Bearing3培林



WP768-Y

BODY	本體材質	Aluminum 鋁
AXLE	軸心材質	Steel 鐵
BEARING	轉動結構	Sealed Bearing & Sleeve Bearing 密封式培林,自潤軸承
SIZE	本體尺寸	102x110mm
WEIGHT	重量	360g/pair



WP891

BODY	本體材質	Aluminum 鋁
AXLE	軸心材質	Steel 鐵
BEARING	轉動結構	Ball Bearing 珠巢
SIZE	本體尺寸	95x112mm
WEIGHT	重量	268g/pair

HUBS

花鼓



NECO



RA01FDQ2

HUB SHELL	外殼材質	Aluminum 鋁
AXLE MATERIAL	軸心材質	Aluminum 鋁 STD length 軸心長:108mm
SEALED BEARING Q'TY	培林數	2
OLD	叉寬	100mm
PCD	孔距	38mm
SPOKE HOLES	孔數	13G/14Gx16H/20H/24H/28H/32H/36H
WEIGHT	重量	139g
REMARKS	備註	Available hole style: Key shape hole or oval shape hole; hole to hole or hole against hole. 可選鑰匙孔或圓孔, 錯孔或對孔

RA01RDQ4

HUB SHELL	外殼材質	Aluminum 鋁
AXLE MATERIAL	軸心材質	Aluminum 鋁 STD length 軸心長:145mm
SEALED BEARING Q'TY	培林數	4
OLD	叉寬	130mm
PCD	孔距	53mm
SPOKE HOLES	孔數	13G/14Gx16H/20H/24H/28H/32H/36H
WEIGHT	重量	320.2g
REMARKS	備註	Available speed: 7/8/9-speed, 10-speed will include washer (1.85mm thick), 11 speed will include longer cassette (1.85mm) 適用7/8/9速, 10速多華司, 11速用長棘輪



RA02FDQ2

HUB SHELL	外殼材質	Aluminum 鋁
AXLE MATERIAL	軸心材質	Aluminum 鋁 STD length 軸心長:108mm
SEALED BEARING Q'TY	培林數	2
OLD	叉寬	100mm
PCD	孔距	38mm
SPOKE HOLES	孔數	13G/14Gx16H/20H/24H/28H/32H/36H
WEIGHT	重量	137.8g
REMARKS	備註	Available hole style: Key shape hole or oval shape hole; hole to hole or hole against hole. 可選鑰匙孔或圓孔, 錯孔或對孔

RA02RDQ4

HUB SHELL	外殼材質	Aluminum 鋁
AXLE MATERIAL	軸心材質	Aluminum 鋁 STD length 軸心長:145mm
SEALED BEARING Q'TY	培林數	4
OLD	叉寬	130mm
PCD	孔距	53mm
SPOKE HOLES	孔數	13G/14Gx16H/20H/24H/28H/32H/36H
WEIGHT	重量	317.8g
REMARKS	備註	Available speed: 7/8/9-speed, 10-speed will include washer (1.85mm thick), 11 speed will include longer cassette (1.85mm) 適用7/8/9速, 10速多華司, 11速用長棘輪



RA03FDQ2

HUB SHELL	外殼材質	Aluminum 鋁
AXLE MATERIAL	軸心材質	Aluminum 鋁 STD length 軸心長:108mm
SEALED BEARING Q'TY	培林數	2
OLD	叉寬	100mm
PCD	孔距	38mm
SPOKE HOLES	孔數	13G/14Gx16H/20H/24H/28H/32H/36H
WEIGHT	重量	139.9g

Available hole style: Key shape hole or oval shape hole; hole to hole or hole against hole. 可選鑰匙孔或圓孔, 錯孔或對孔

REMARKS 備註



RA03RDQ4

HUB SHELL	外殼材質	Aluminum 鋁
AXLE MATERIAL	軸心材質	Aluminum 鋁 STD length 軸心長:145mm
SEALED BEARING Q'TY	培林數	4
OLD	叉寬	130mm
PCD	孔距	53mm
SPOKE HOLES	孔數	13G/14Gx16H/20H/24H/28H/32H/36H
WEIGHT	重量	327.4g

Available speed: 7/8/9-speed, 10-speed will include washer (1.85mm thick), 11 speed will include longer cassette (1.85mm) 適用7/8/9速, 10速多華司, 11速用長棘輪

REMARKS 備註



MS03FDQ2

HUB SHELL	外殼材質	Aluminum 鋁
AXLE MATERIAL	軸心材質	Aluminum 鋁
SEALED BEARING Q'TY	培林數	2
OLD	叉寬	100mm
PCD	孔距	58mm
SPOKE HOLES	孔數	13G/14Gx20H/24H/28H/32H/36H
		MA03FDQ2:W/Aluminum Axle & Cover
UPGRADE	可選配項目	鋁軸心&側蓋
WEIGHT	重量	274g
FINISH	表面處理	Silver & Black, 銀&黑



MS03RDQ4

HUB SHELL	外殼材質	Aluminum 鋁
AXLE MATERIAL	軸心材質	Aluminum 鋁
SEALED BEARING Q'TY	培林數	4
OLD	叉寬	135mm
PCD	孔距	58mm
SPOKE HOLES	孔數	13G/14Gx20H/24H/28H/32H/36H
		MA03RDQ2:W/Aluminum Axle & Cover
UPGRADE	可選配項目	鋁軸心&側蓋
WEIGHT	重量	353g
FINISH	表面處理	Silver & Black, 銀&黑



MS07FDQ2

HUB SHELL	外殼材質	Aluminum 鋁
AXLE MATERIAL	軸心材質	Aluminum 鋁
SEALED BEARING Q'TY	培林數	2
OLD	叉寬	100mm
PCD	孔距	58mm
SPOKE HOLES	孔數	13G/14Gx20H/24H/28H/32H/36H MA07FDQ2:W/Aluminum Axle & Cover
UPGRADE	可選配項目	鋁軸心&側蓋
WEIGHT	重量	263g
FINISH	表面處理	Silver & Black, 銀&黑



MS07RDQ4

HUB SHELL	外殼材質	Aluminum 鋁
AXLE MATERIAL	軸心材質	Aluminum 鋁
SEALED BEARING Q'TY	培林數	4
OLD	叉寬	135mm
PCD	孔距	58mm
SPOKE HOLES	孔數	13G/14Gx20H/24H/28H/32H/36H MA07RDQ2:W/Aluminum Axle & Cover
UPGRADE	可選配項目	鋁軸心&側蓋
WEIGHT	重量	340g
FINISH	表面處理	Silver & Black, 銀&黑

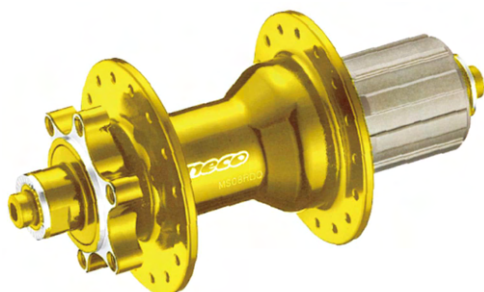

MS08RDQ4

HUB SHELL	外殼材質	Aluminum 鋁
AXLE MATERIAL	軸心材質	Aluminum 鋁
SEALED BEARING Q'TY	培林數	4
OLD	叉寬	135mm
PCD	孔距	58mm
SPOKE HOLES	孔數	13G/14Gx20H/24H/28H/32H/36H MA08RDQ2:W/Aluminum Axle & Cover
UPGRADE	可選配項目	鋁軸心&側蓋
WEIGHT	重量	341g
FINISH	表面處理	Silver & Black, 銀&黑

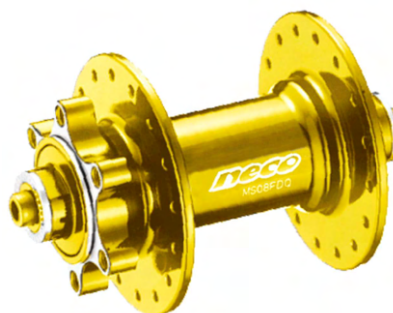

MS08FDQ2

HUB SHELL	外殼材質	Aluminum 鋁
AXLE MATERIAL	軸心材質	Aluminum 鋁
SEALED BEARING Q'TY	培林數	2
OLD	叉寬	100mm
PCD	孔距	58mm
SPOKE HOLES	孔數	13G/14Gx20H/24H/28H/32H/36H MA08FDQ2:W/Aluminum Axle & Cover
UPGRADE	可選配項目	鋁軸心&側蓋
WEIGHT	重量	210g
FINISH	表面處理	Silver & Black, 銀&黑



MS09FDQ2

HUB SHELL	外殼材質	Aluminum 鋁
AXLE MATERIAL	軸心材質	Aluminum 鋁
SEALED BEARING Q'TY	培林數	2
OLD	叉寬	100mm
PCD	孔距	58mm
SPOKE HOLES	孔數	13G/14Gx24H/28H/32H/36H
		MA09FDQ2:W/Aluminum Axle & Cover
UPGRADE	可選配項目	鋁軸心&側蓋
WEIGHT	重量	197g
FINISH	表面處理	Silver & Black, 銀&黑



MS09RDQ4

HUB SHELL	外殼材質	Aluminum 鋁
AXLE MATERIAL	軸心材質	Aluminum 鋁
SEALED BEARING Q'TY	培林數	4
OLD	叉寬	135mm
PCD	孔距	58mm
SPOKE HOLES	孔數	13G/14Gx24H/28H/32H/36H
		MA09RDQ2:W/Aluminum Axle & Cover
UPGRADE	可選配項目	鋁軸心&側蓋
WEIGHT	重量	418g
FINISH	表面處理	Silver & Black, 銀&黑



MS641F

HUB SHELL	外殼材質	Aluminum 鋁
AXLE MATERIAL	軸心材質	SC45
OLD	叉寬	100mm
PCD	孔距	38mm
ROLLING SYSTEM	轉動機構	Loose Ball 散珠
SPOKE HOLES	孔數	13G/14Gx24H/28H/32H/36H
WEIGHT	重量	155g
REMARKS	備註	black/silver/blue/golden 黑/銀/藍/金



MS641R

HUB SHELL	外殼材質	Aluminum 鋁
AXLE MATERIAL	軸心材質	SC45
OLD	叉寬	135mm
PCD	孔距	45mm
ROLLING SYSTEM	轉動機構	Loose Ball 散珠
SPOKE HOLES	孔數	13G/14Gx24H/28H/32H/36H
WEIGHT	重量	245g
REMARKS	備註	black/silver/blue/golden 黑/銀/藍/金



MS3951F

HUB SHELL	外殼材質	Aluminum 鋁
AXLE MATERIAL	軸心材質	SC45
OLD	叉寬	100mm
PCD	孔距	58mm
ROLLING SYSTEM	轉動機構	Loose Ball 散珠螺紋式
SPOKE HOLES	孔數	13G/14Gx24H/28H/32H/36H
WEIGHT	重量	270g
REMARKS	備註	black/sliver/blue/golden 黑/銀/藍/金



MS3951R

HUB SHELL	外殼材質	Aluminum 鋁
AXLE MATERIAL	軸心材質	SC45
OLD	叉寬	135mm
PCD	孔距	58mm
ROLLING SYSTEM	轉動機構	Loose Ball 散珠螺紋式
SPOKE HOLES	孔數	13G/14Gx24H/28H/32H/36H
WEIGHT	重量	475g
REMARKS	備註	black/sliver/blue/golden 黑/銀/藍/金



MS37F

HUB SHELL	外殼材質	Aluminum 鋁
AXLE MATERIAL	軸心材質	SC45
OLD	叉寬	100mm
PCD	孔距	58mm
ROLLING SYSTEM	轉動機構	Loose Ball 散珠
SPOKE HOLES	孔數	13G/14G*x24H/28H/32H/36H
WEIGHT	重量	276g
REMARKS	備註	black/sliver/blue/golden 黑/銀/藍/金



MS37R

HUB SHELL	外殼材質	Aluminum 鋁
AXLE MATERIAL	軸心材質	SC45
OLD	叉寬	135mm
PCD	孔距	58mm
ROLLING SYSTEM	轉動機構	Loose Ball 散珠
SPOKE HOLES	孔數	13G/14Gx24H/28H/32H/36H
WEIGHT	重量	332g
REMARKS	備註	black/sliver/blue/golden 黑/銀/藍/金



MS373F

HUB SHELL	外殼材質	Aluminum 鋁
AXLE MATERIAL	軸心材質	SC45
OLD	叉寬	100mm
PCD	孔距	58mm
ROLLING SYSTEM	轉動機構	Loose Ball 散珠
SPOKE HOLES	孔數	13G/14Gx24H/28H/32H/36H
WEIGHT	重量	279g



MS373R

HUB SHELL	外殼材質	Aluminum 鋁
AXLE MATERIAL	軸心材質	SC45
OLD	叉寬	135mm
PCD	孔距	58mm
ROLLING SYSTEM	轉動機構	Loose Ball 散珠
SPOKE HOLES	孔數	13G/14Gx24H/28H/32H/36H
WEIGHT	重量	459g



MS38F

HUB SHELL	外殼材質	Aluminum 鋁
AXLE MATERIAL	軸心材質	SC45
OLD	叉寬	100mm
PCD	孔距	58mm
ROLLING SYSTEM	轉動機構	Loose Ball 散珠
SPOKE HOLES	孔數	13G/14Gx24H/28H/32H/36H
WEIGHT	重量	287g
REMARKS	備註	black/silver/blue/golden 黑/銀/藍/金



MS38R

HUB SHELL	外殼材質	Aluminum 鋁
AXLE MATERIAL	軸心材質	SC45
OLD	叉寬	135mm
PCD	孔距	58mm
ROLLING SYSTEM	轉動機構	Loose Ball 散珠
SPOKE HOLES	孔數	13G/14Gx24H/28H/32H/36H
WEIGHT	重量	465g
REMARKS	備註	black/silver/blue/golden 黑/銀/藍/金



HA102F

HUB SHELL	外殼材質	Aluminum 鋁
AXLE MATERIAL	軸心材質	SC45
OLD	叉寬	135mm
PCD	孔距	58mm
ROLLING SYSTEM	轉動機構	Loose Ball 散珠
SPOKE HOLES	孔數	12G/13Gx32Hx36H
WEIGHT	重量	316g



HA450F-100

HUB SHELL	外殼材質	Aluminum 鋁
OLD	叉寬	100mm/110mm
PCD	孔距	58mm
SEALED BEARING Q'TY	培林數	2
SPOKE HOLES	孔數	13Gx32H/36H
WEIGHT	重量	218g



HA450F-150

HUB SHELL	外殼材質	Aluminum 鋁
OLD	叉寬	150mm
PCD	孔距	58mm
SEALED BEARING Q'TY	培林數	2
SPOKE HOLES	孔數	12G/13Gx32Hx36H
WEIGHT	重量	280g



HA450R

HUB SHELL	外殼材質	Aluminum 鋁
OLD	叉寬	142mm/148mm
PCD	孔距	58mm
SEALED BEARING Q'TY	培林數	4
SPOKE HOLES	孔數	13Gx32H/36H
WEIGHT	重量	358g



KTG12

MATERIAL	材質	Aluminum 鋁
LENGTH	長度	120mm/121mm/123mm/125mm 142mm/162mm/164mm/165mm 168mm/171mm/173mm/175mm
THREAD	牙紋	M12,M15



Q01

MATERIAL	材質	Aluminum 鋁
AXLE	軸心	Steel 鐵
WEIGHT	重量	FRONT 前: 51.5g REAR 後: 57.5g



Q07

MATERIAL	材質	Aluminum 鋁
AXLE	軸心	Steel 鐵
WEIGHT	重量	FRONT 前: 56g REAR 後: 62g



Q17

MATERIAL	材質	Aluminum 鋁
AXLE	軸心	Steel 鐵
WEIGHT	重量	FRONT 前: 50.5g REAR 後: 56.5g



Q27

MATERIAL	材質	Aluminum 鋁
AXLE	軸心	Steel 鐵
WEIGHT	重量	FRONT 前: 56.4g REAR 後: 61.8g

HEADSET PACKING



MFH - 21 (1")



MFH-2 (1-1/8")



MFH-11(1-1/8")



**MFH-12
(1-1/2")**



**MFH-1
(1" & 1-1/8")**

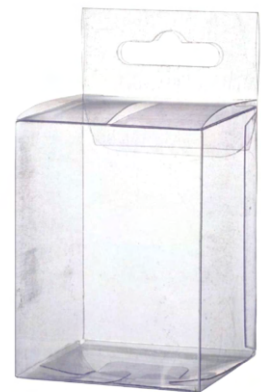

MFH-3



MFH-4

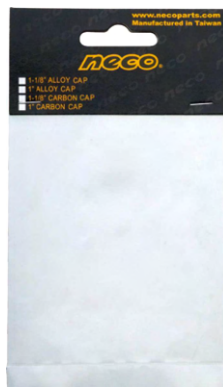

MFC-1



MFC-2

BOTTOM BRACKET PACKING



MFB-5



MFB-6



MFB-3



MFB-21



MFB-2



MFB-1



**HUBS
PACKAGING**



**PEDAL
PACKAGING**



**PEDAL
PACKAGING**

NECO

CATALOGUE & TECHNICAL MANUAL

2025

2026

誌慶工業股份有限公司(台灣總部) Neco Technology Industry Co, Ltd (Headquarters)

ADD : No.190, Zhongzheng Rd., Wufeng Dist., Taichung City 41362, Taiwan

TEL : +886-4-2332 3966 FAX:+886-4-2332-2866 EMAIL: neco@necoparts.com

廣東志慶精密五金有限公司Guangdong Zhiqing Precision Hardware Parts Co. Ltd

ADD : Unit101,Buliding 9rd.,Jilong Zhizao Park,No.52 Xilian Road,Longyan Village,Leliu,Shunde,Foshan,Guangdong,528300,China

TEL : +86-757-22626559

FAX : +86-757-22626459

EMAIL : sdneco@vip.126.com

江蘇誌慶精密五金零件有限公司Jiangsu Zhiqing Precision Hardware Parts Co. Ltd

ADD : Industrial Concentration Zone,Tianwang Town,Jurong City,Jiangsu Province,China

TEL : +86-511-80275988

EMAIL : neco-zj@vip.163.com,necoparts@163.com

志慶科技(天津)有限公司Neco Technology(TIANJIN)Co.,LTD

ADD : No.17, 24th Road Jinghai Economic Development Zone, Jinghai Town Tianjin China

TEL : +86-22-59591630

EMAIL : tianjinneco@163.com

零貝電機科技(上海)有限公司 Lingbei Motor Technology (SHANGHAI) CO.,Ltd

OFFICE ADD : No.5158 Dongchuan Road,Pudong New Area Shanghai,China

PRODUCTION ADD : Industrial Concentration Zone,Tianwang Town,Jurong City,Jiangsu Province,China

TEL : +86-21-68412951

FAX : +86-21-20428126

EMAIL : necomotorrexchen@lingbeimotor.cn

